

Relay Communication Equipment

Table of contents see next page

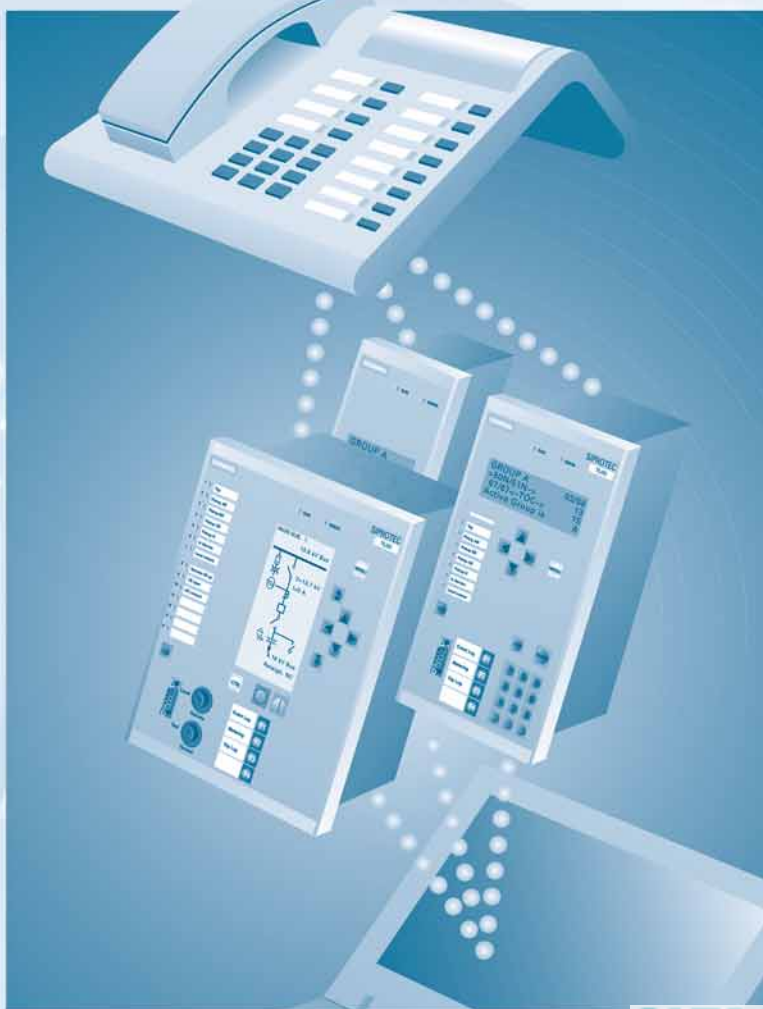

<i>Contents</i>	<i>Page</i>
<i>7XV5101 RS232 – FO Connector Module</i>	13/3
<i>7XV5103 RS485 Bus System up to 115 kbit/s</i>	13/5
<i>7XV5104 Bus Cables for Time Synchronization</i>	13/13
<i>7XV5105 Bus Cable for Time Synchronization (for 7SD5 Relays)</i>	13/15
<i>7XV5450 Mini Star-Coupler</i>	13/17
<i>7XV5461 Two-Channel Serial Optical Repeater (for duplex mono-mode FO cables)</i>	13/21
<i>7XV5461 Two-Channel Serial Optical Repeater (for 1 mono-mode FO cables)</i>	13/25
<i>7XV5461 Two-Channel Serial Optical Repeater (for duplex multi-mode FO cables)</i>	13/29
<i>7XV5550 Active Mini Star – Coupler</i>	13/33
<i>7XV5650/5651 RS485 – FO Converter</i>	13/37
<i>7XV5652 RS232 – FO Converter</i>	13/41
<i>7XV5653 Two – Channel Binary Transducer</i>	13/45
<i>7XV5655 Ethernet Modem for Substations</i>	13/49
<i>7XV5655 Ethernet Serial Hub for Substations</i>	13/53
<i>7XV5662 Communication Converter X.21/RS422 and G.703.1</i>	13/57
<i>7XV5662 Communication Converter for Pilot Wires</i>	13/61
<i>7XV5662 Two-Channel Serial Communication Converter G.703.6</i>	13/65
<i>7XV5662 6AD10 RTD-box / Thermobox TR1200</i>	13/69
<i>7XV5662 7AD10 Universal Relay/RTD-Box TR800</i>	13/73
<i>7XV5662 8AD10 RTD-box / Thermobox TR1200 IP</i>	13/77
<i>7XV5664/7XV5654 GPS/DFC77 Time Synchronization System</i>	13/81
<i>7XV5673 I/O-Unit with 6 Binary In-/Outputs</i>	13/85
<i>7XV5700 RS232 – RS485 Converter</i>	13/93
<i>7XV5710 USB – RS485 Converter Cable</i>	13/97
<i>7XV5820 Industrial Modem and Modem-Router with Switch</i>	13/101
<i>7XV5850 Ethernet Modems for Office Applications</i>	13/109
 <i>Accessories for Communication</i>	
<i>6XV8100 F.O. Link Cable</i>	13/113
<i>7KE6000-8Gx Ethernet Patch Cable</i>	13/114

7XV5101 RS232-FO Connector Module



Fig. 13/1
Connector modules/adapters 7XV5101-3C

Description

Connector modules 7XV5101

Optical connection of protection relays with an electrical (non-isolated) RS232 interface, e.g. to a star coupler, for centralized control is made possible with the fiber-optic RS232 connector modules.

Thus, further devices such as PCs or notebooks, modems or serial data switches can be effectively protected against electromagnetic interference. An appropriate connector module is available for each of the above-mentioned applications. These fiber-optic RS232 connector modules are housed in a SUB-D plug casing and can be directly plugged into the respective interfaces of the pertaining devices. No further settings are required. In its normal position, the optical interface is set to steady light OFF. Data transmission is fully duplex and transparent. The optical interface with FSMA connectors has an operational wavelength of 820 nm and can reach distances of up to 1500 m with 62.5/125 μm multi-mode FO cables.

Technical data

		7XV5101- 3C	
Housing	Plastics, metal-plated	X	
	Dimensions 72 x 32 x 17 mm	X	
	Via external keyboard connector located at the notebook	X	
Electrical interfaces	Bridge contact 7 - 8, 1 - 4 - 6	9-pin	X
Optical interfaces	FSMA connector (screw-type)	T = transmit, R = receive	X
	Optical power	27 μ W (- 15.7 dBm) ¹⁾	X
	Sensitivity	1 μ W (- 30 dBm) ¹⁾	X
	Optical budget	7 dB (+ 3 dB backup) ¹⁾	X
	Wavelength	850 nm	X
	Transmission range	1500 m (with 62.5 μ m multi-mode FO cable) 800 m (with 50 μ m multi-mode FO cable)	X

1) Valid for 62.5 μ m FO cable.

Selection and ordering data

Description	Order No.
7XV5101 fiber-optic connector module 820 nm - RS232	7XV5101-3C
<i>9-pin female connector for notebook</i>	

7XV5103 RS485 Bus Systems up to 115 kbit/s (not suitable for PROFIBUS)

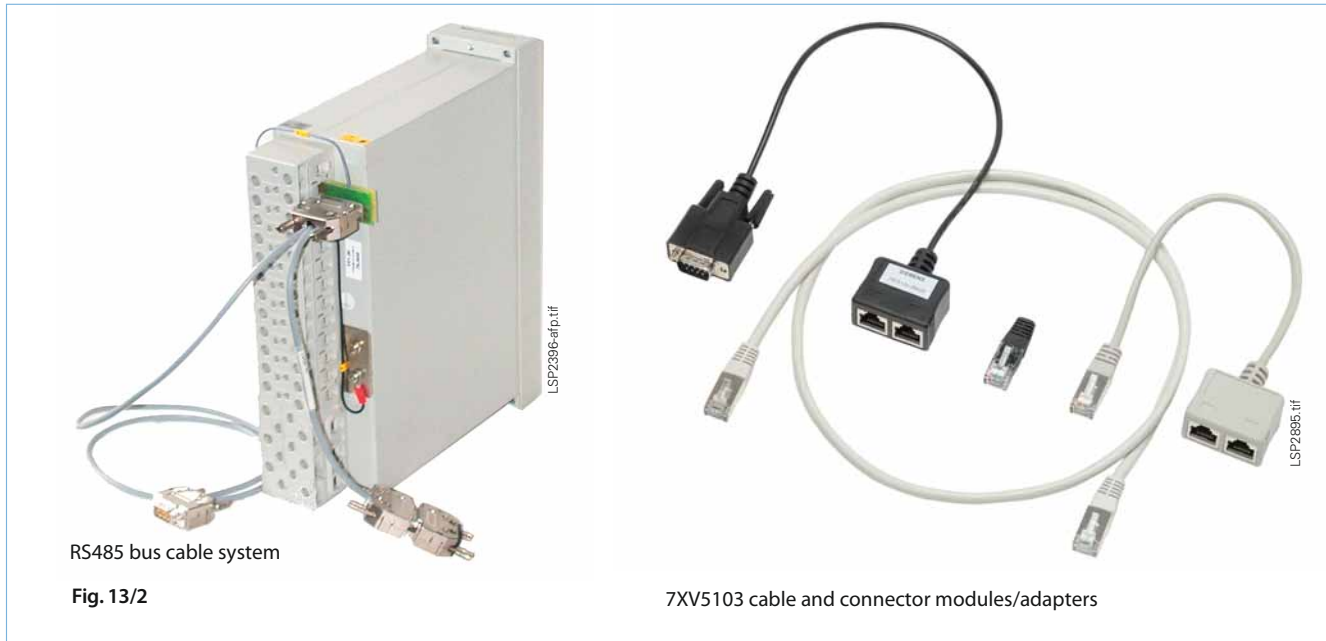

RS485 bus cable system

Fig. 13/2

7XV5103 cable and connector modules/adapters

Description

The RS485 bus is a low-cost half-duplex communication bus, which, due to its relatively high interference immunity, is not only used for monitoring and control in industrial systems, but is now increasingly used for SCADA and protection applications by utilities in substations. Protocols, such as DIGSI, IEC 60870-5-103, DNP 3 and MODBUS up to 115 kbit/s, are used between a station master and up to 31 slave devices on shielded twisted-pair (STP) cable. In ideal conditions, the length of the bus may be up to 1000 m. This requires correct configuration of the bus, use of suitable cables, and connector connectors, as well as correct termination of the bus. Devices with different termination methods require special adaptors to achieve the highest possible interference immunity. The RS485 bus systems 7XV5103 are optimized in this respect for our control and protection product range.

With the ordering code 7XV5103, two different RS485 bus systems are available.

When combining the required components for a RS485 bus, the corresponding application examples contained in this document can be of assistance.

The bus system with 9-pin SUB-D connectors has long been applied in systems with SIPROTEC protection devices, 7XV5 converters, and master units. Connection to the individual devices is achieved directly with a special Y-cable or with a corresponding adapter cable to devices with different termination methods. The bus terminates in a 9-pin SUB-D bus terminating connector with an integrated 220-Ω resistor.

On some SIPROTEC devices, the serial signals are routed to RJ45 female connectors on the communication module, as is the case, for example, with the redundant IEC 60870-5-103 module. There the bus is based on double-shielded CAT 5 patch cables. Connection of the individual devices to the two redundant buses is achieved via two special Y-adapter cables each. The buses each terminate with a RJ45 bus terminating connector with a 120-Ω resistor.

A combination of the two bus systems and the different device interfaces or a combination of the two systems is also possible using the Y-adapter cable 7XV5103-2BA00.

Function overview

- For data transfer up to 115 kbit/s (e.g. DIGSI, IEC 60870-5-103, DNP 3)
- Variable bus structure with shielded cables of various lengths.
- Metal-plated, shielded connector housings with reduced mounting depth and strain relief.
- Bus termination with terminating connectors and integrated resistor.
- Connection of the SIPROTEC 4 protection devices with redundant IEC 60870-5-103 interface via the Y-adapter cable and RJ45 connector.
- Connection of the SIPROTEC 4 protection devices with RS485 interface and SUB-D connector directly, or via a Y-adapter cable.
- Adapter/cable for compact protection devices with RS485 interface on screw-type terminals, e.g. 7SJ600, 7SD600, 7RW600 etc.
- Connection to various RS485 converters, e.g. 7XV5650/51.
- Combination of both bus systems is possible.
- Max. length of the bus within a common grounding system may be up to 1000 m.

Please note that this system must not be used for PROFIBUS-FMS or PROFIBUS-DP. These have their own bus system with components suitable for use with PROFIBUS.

Application

Notes on configuring the RS485 bus system

The housings of all devices connected to the bus must be **solidly grounded** to a common ground to avoid dangerous ground currents flowing via the cable shields.

Larger distances, especially into other buildings with separate grounding system should preferably be covered via converters (e.g. 7XV5650/51) using FO links.

The RS485 bus must be **linear**, i.e. tee-offs from the bus (e.g. a terminal strip) to the connected bus devices must not be used. This would form a star configuration, which has negative influence on the functionality.

The bus must be terminated at the first device (usually the master) and at the last device with a **bus terminating resistor** to avoid interference due to reflection. No further terminating resistors must be connected between these terminals.

As all of the devices, maximum 32 (including the master) are listening in on the RS485 bus, all the devices on the bus must be set to **the same baud rate and the same data format**.

The slaves must all have different **device addresses**.

Within the system, **only one master may be active** at any one time and only one slave may respond.

The bus system with 9-pin SUB-D connectors

The bus system with 9-pin SUB-D bus terminating connectors has long been used with SIPROTEC protection devices, the converters 7XV5 and Siemens master units. Connection of individual devices to devices with various connection modes is achieved directly via specialized Y cables, or via suitable adapter cables. The bus terminates at a 9-pin SUB-D bus terminating connector with an integrated 220-Ω resistor.



Fig. 13/3 Protection unit connected to the RS485 bus

Specifications

- Direct connection to SIPROTEC 4 protection devices with RS485 interface via a FO-RS485 converter 7XV5650/51
- Adapter/cable for compact protection devices with RS485 interface on screw-type terminals, e.g. 7SJ600, 7SD600, 7RW600 etc.
- 4 cable lengths from 1 to 10 meters
- Shielded twisted-pair (STP) cable with 9-pin SUB-D connector connectors
- Metal-plated, shielded connector housings with reduced mounting depth and strain relief
- Data transfer up to 115 kbit/s (e.g. DIGSI, IEC 60870-5/VDEW)
- Maximum length of the bus up to 1000 m within a common grounding system
- Bus termination with terminating connectors and integrated 220-Ω resistor

Application

Application example 1:

The 9-pin male connector of the Y bus cable S1 always comes from the master side and provides the connection to the slaves via the 1, 3, 5 or 10-m cable and 9-pin male connector S2. At the connector S2 a 20-cm long cable with a 9-pin female connection B3 is provided to extend the bus. The compact protection devices, e.g. 7SJ600 are directly connected via the adapter cable 7XV5103-2AA00 with female connector B2 or an RS485 adapter 7XV5103-3AA00. After the final device, a bus terminating connector 7XV5103-5AA00 is connected to connector B3 to terminate the bus.

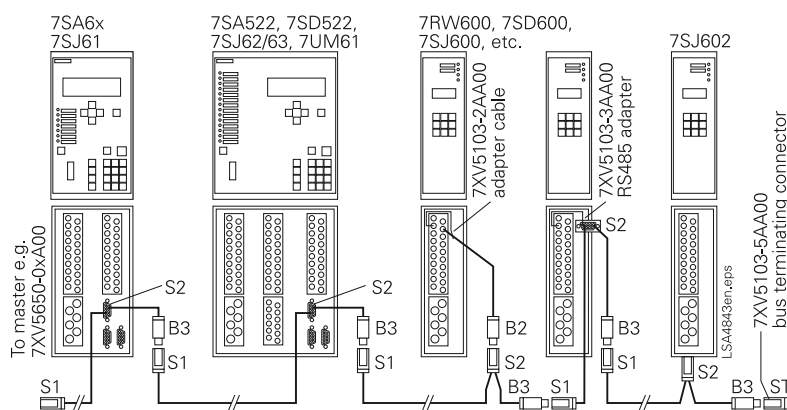

Fig. 13/4 SIPROTEC protection devices on the RS485 bus

Selection and ordering data

Description	Order No.
<i>RS485 Y-bus cable shielded twisted pair with 9-pin SUB-D connectors</i>	7XV5103-0AA□□
<i>7XV5103 RS485 bus with SUB-D connectors</i>	
Length 1 m	0 1
Length 3 m	0 3
Length 5 m	0 5
Length 10 m	1 0
<i>RS485 bus extension cable STP with 9-pin SUB-D connector</i>	7XV5103-1AA□□
Length 10 m	1 0
Length 20 m	2 0
Length 30 m	3 0
Length 40 m	4 0
Length 50 m	5 0
<i>RS485 adapter</i>	7XV5103-□AA00
Adapter cable with STP with ferrule/9-pin SUB-D connector for units with screw-type terminals or compact protection units, e.g. 7SJ600, 7SD600 etc.	2
RS485 adapter with 9-pin SUB-D connector for mounting on screw-type terminals on compact protection units, e.g. 7SJ600, 7SD600 etc.	3
Bus terminating connector 220-Ω, 9-pin SUB-D connector	5
<i>RS485 cable to thermo-box (RTD)</i>	7XV5103-7AA□□
For connection between the 7XV5662-□AD10 thermo-box and SIPROTEC 4 units (port C or port D with RS485 interface)	
Length 5 m	0 5
Length 25 m	2 5
Length 50 m	5 0

Application

Bus system with RJ45 patch cables

The bus system with RJ45 connectors was specially developed for SIPROTEC devices for communication modules with serial RJ45 connectors and is built with low cost double-shielded CAT 5 patch cables.

Connection of the individual devices to the two redundant buses is achieved via two special Y-adapter cables each. The buses each terminate with a RJ45 bus terminating connector with an integrated 120-Ω resistor.

Specifications

- Low-cost bus structure with shielded patch cables (CAT 5) with RJ45 connectors
- Cable lengths from 0.5 to 20 meters (7KE6000-8G)
- Connection of SIPROTEC 4 protection devices with redundant IEC 60870-5-103 interfaces via Y-adapter with RJ45 connector
- Connection of SIPROTEC 4 protection devices with RS485 interface via Y-cable to SUB-D connector
- Adapter/cable for compact protection devices, e.g. 7SJ600, 7SD600, 7RW600 etc.
- Metal-plated connector housings with strain relief of the cable connections
- Compact connectors
- Data transfer up to 115 kbit/s (e.g. DIGSI, IEC 60870-5/VDEW)
- Maximum extension of the bus of up to 800 m within a common grounding system
- Bus termination with terminating connectors and integrated 120-Ω resistor
- Connection to the FO-RS485 converter 7XV5650 or the bus system with SUB-D connector via Y-adapter

Notes on configuring the RS485 bus system (application examples 2 and 3, see page 13/9)

The housings of all devices connected to the bus must be solidly grounded to a common ground to avoid dangerous ground currents flowing via the cable shields.

Larger distances, especially into other buildings with separate grounding system should preferably be covered via converters (e.g. 7XV5650/51) using FO cables.

The RS485 bus must be linear, i.e. tee-offs from the bus (e.g. a terminal strip) to the connected bus devices must not be used. This would form a star configuration, which has negative influence on the functionality.



Fig. 13/5 Bus system with RJ45 patch cable

Only CAT 5 double-shielded patch cables (e.g. 7KE6000) must be used as the bus cables. The maximum bus length must not exceed 800 m.

The bus must be terminated at the first device (usually the master) and at the last device with a bus terminating resistor to avoid interference due to reflection. No further terminating resistors must be connected between these terminals.

As all of the devices, maximum 32 (including the master) are listening in on the RS485 bus, all the devices on the bus must be set to the same baud rate and the same data format. The slaves must all have different device addresses.

Within the system on each bus, only one master may be active at any one time and only one slave may respond.

Application

Application example 2: Connection of SIPROTEC 4 to a (redundant) control system

The RS485 bus cable system with patch cables (CAT 5) was developed as a low-cost alternative to the previous systems 7XV5103 with SUB-D connectors. The advantages are the widespread use of patch cables throughout the world and the compact dimensions of the RJ45 connector. This allows a redundant IEC 60870-5-103 interface with a single interface module within a SIPROTEC 4 device.

Two different Y-adapters permit implementation of a RS485 bus with patch cables and connection of devices having RS485 interfaces and different designs of interface connector. Both Y-adapters have two RJ45 female connectors in parallel to facilitate the implementation of the buses. The approx. 20 cm long connection cable to the device either has a RJ45 or SUB-D connector.

Devices with SUB-D connector (e.g. Master RTU, 7XV5650/51, SIPROTEC 4 devices with SUB-D) are connected using the Y-adapter 7XV5103-2BA00.

Devices with RJ45 connector such as SIPROTEC 4 with redundant IEC 60870-5-103 interface are connected with the Y-adapter 7XV5103-2CA00. For the redundant bus system 2 Y-adapters are required per SIPROTEC 4 device.

After the final device the bus is terminated with a bus terminating connector 7XV5103-5BA00. For the redundant bus system, a bus terminating resistor is required for each bus.

Application example 3: Central operation of SIPROTEC 4 units with DIGSI 4

The RS485-bus cable system with patch cables (CAT 5) was developed as a low-cost alternative to the previous systems 7XV5103 with SUB-D connectors. The advantages are the widespread use of patch cables throughout the world and the compact dimensions of the RJ45 connector.

The Y-adapter 7XV5103-2BA00 allows for the implementation of a RS485 bus with patch cables and the connection of various SIPROTEC 4 devices having RS485 interfaces. The Y-adapters have two RJ45 female connectors in parallel to facilitate the implementation of the buses. The approx. 20 cm long connection cable to the device has a RJ45 with suitable pin allocation.

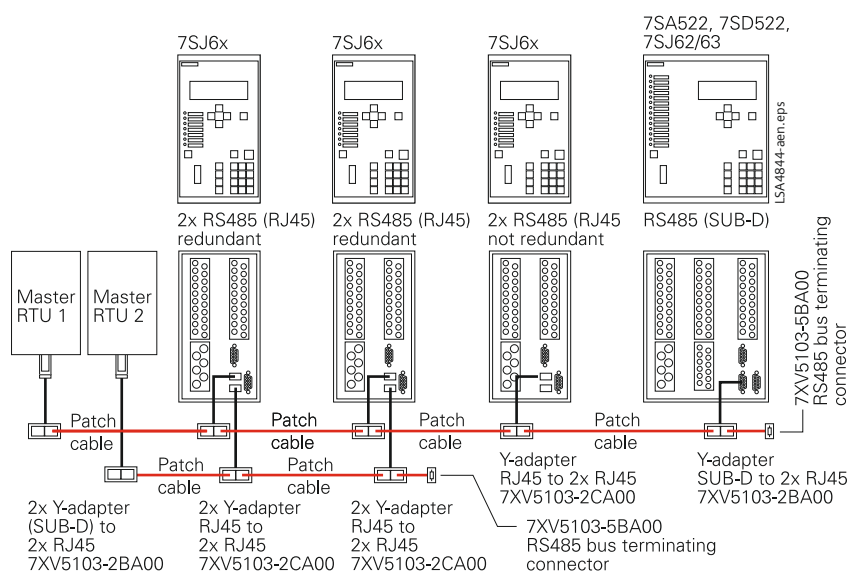

Fig. 13/6 Connection of SIPROTEC 4 to a (redundant) control system

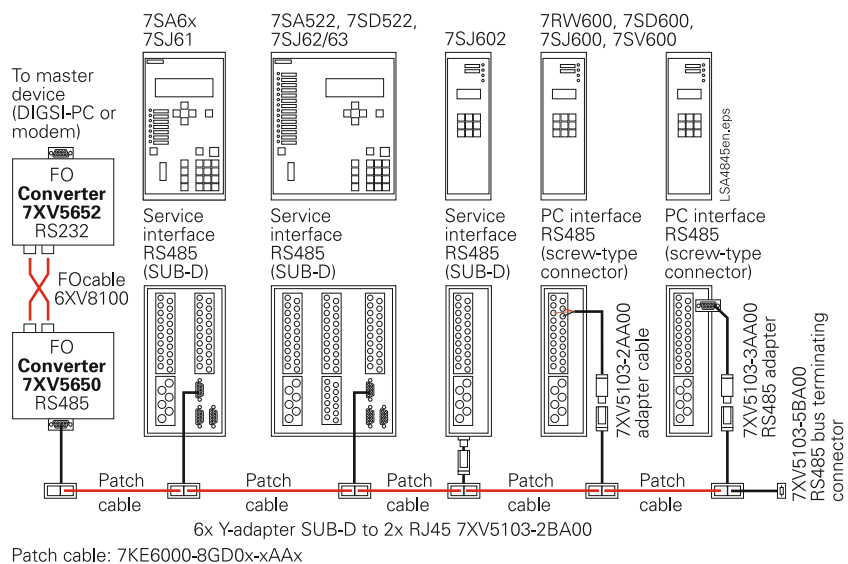

Fig. 13/7 Central operation of SIPROTEC 4 units with DIGSI 4

Devices with an RS485 interface and SUB-D connector (7XV5650/51, SIPROTEC 4 devices) with SUB-D are connected using the Y-adapter 7XV5103-2BA00.

Devices with an RS485 interface on screw-type connectors require an additional adapter for 9-pin SUB-D to single core, e.g. 7XV5103-2AA00 or 7XV5103-3AA00.

After the last device, the bus is terminated with a bus terminating connector 7XV5103-5BA00.

Selection and ordering data

Description	Order No.
<i>RS485 adapter/accessories</i>	<i>7XV5103-□□□00</i>
Adapter cable STP with ferrule/9-pin SUB-D connection for devices with screw-type terminals or compact protection devices, e.g. 7SJ600	2 A A
Y-adapter cable for connection of SIPROTEC 4 or other devices with a 9-pin SUB-D connection to a RS485 bus with patch cables (RJ45)	2 B A
Y-adapter cable for connection of SIPROTEC 4 with a redundant T103 interface module to a RS485 bus with patch cables (RJ45)	2 C A
RS485 adapter with 9-pin SUB-D connection for mounting on screw-type terminals with compact protection devices, e.g. 7SJ600, 7SD600 etc.	3 A A
Bus terminating connector 220-Ω in a 9-pin SUB-D connector	5 A A
Bus terminating connector 120-Ω in a RJ45 connector	5 B A
<i>Patch cable CAT 5 shielded with RJ45 connectors</i>	<i>7KE6000-8GD0□-□AA0/BB</i>
See Accessories for Communication 7KE6000-8Gx	

Application

Application example 4: Connecting the two bus systems 7XV5103

The Y-adapter 7XV5103-2BA00 enables configuration of the RS485 bus with RJ45 patch cables and connection of SIPROTEC devices with an RS485 interface with a SUB-D connector.

Use of an additional gender changer (female-female) enables connection of a RS485 bus with Y-bus cables 7XV5103-0AAxx instead of a SIPROTEC device.

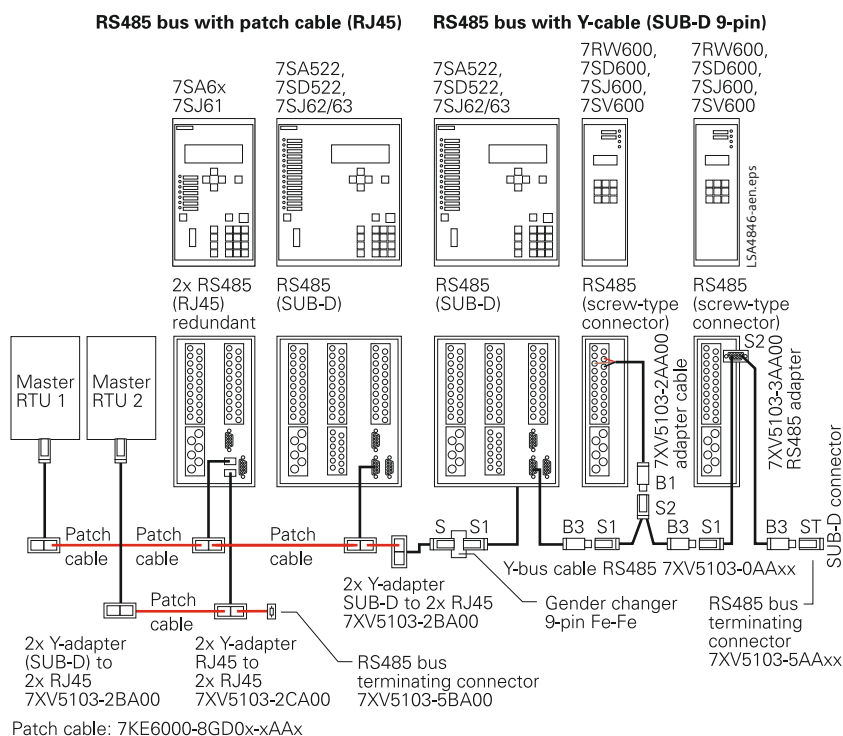

Fig. 13/8 Connecting the two 7XV5103 bus systems

Selection and ordering data

Description	Order No.
<i>RS485 Y-bus cable shielded twisted-pair with 9-pin SUB-D connector</i>	<i>7XV5103-0AA□□</i>
Length 1 m	0 1
Length 3 m	0 3
Length 5 m	0 5
Length 10 m	1 0
<i>RS485 bus cable extension STP with 9-pin SUB-D connector</i>	<i>7XV5103-1AA□□</i>
Length 10 m	1 0
Length 20 m	2 0
Length 30 m	3 0
Length 40 m	4 0
Length 50 m	5 0
<i>RS485 adapter/accessories</i>	<i>7XV5103-□□□00</i>
Adapter cable STP with ferrule/9-pin SUB-D connector for devices with screw-type terminals or compact protection devices, e.g. 7SJ600	2 A A
Y-adapter cable for connection of SIPROTEC 4 or other devices with 9-pin SUB-D connection to a RS485 bus with patch cables (RJ45)	2 B A
Y-adapter cable for connection of SIPROTEC 4 with a redundant T103 interface module to a RS485 bus with patch cables (RJ45)	2 C A
RS485 adapter with 9-pin SUB-D connector for mounting to screw-type terminals for compact protection devices, e.g. 7SJ600, 7SD600 etc.	3 A A
Bus terminating connector 220-Ω in a 9-pin SUB-D connector	5 A A
Bus terminating connector 120-Ω in a RJ45 connector	5 B A
<i>RS485 cable to thermo-box (RTD)</i>	<i>7XV5103-7AA□□</i>
Connection cable for thermo-box 7XV5662-xAD to SIPROTEC 4 Open cable ends, each 5 / 20 cm with ferrules to 9-pin SUB-D connector with an integrated 220-Ω terminating resistor	0 5
Length 5 m	0 5
Length 25 m	2 5
Length 50 m	5 0
<i>Patch cable CAT 5 shielded with RJ45 connector</i>	<i>7KE6000-8GD0□-□AA0/BB</i>
See Accessories for Communication 7KE6000-8G	

7XV5104 Bus Cable for Time Synchronization



Fig. 13/9 RS485 bus system

Function overview

- Opto-electrical solution for SIPROTEC 4 devices with IRIG-B interface (Port A)
- Direct connection of SIPROTEC 4 devices with IRIG-B interface to sync.-transceiver 7XV5654
- Adapter/cable for cascading and matching to other converters
- 4 orderable cable lengths from 1 m to 10 m
- 2-core, twisted and shielded cable with 9-pin SUB-D connectors
- Metal plug connector casings with fixing screws and strain relief for cable connections
- Compact dimensions of the plugs
- Max. extent of electrical bus 20 m within building

Description

The evaluation of fault records, operational alarms and fault signals calls for millisecond-accurate determination of the absolute time. The SIPROTEC 4 units have an internal clock on a quartz basis, which deviates from the normal time after a while. Radio clocks are therefore used for precise synchronization; they set the clocks in the devices via time signals or protocols such as DCF77 or IRIG-B. All the devices are connected in parallel with an electrical bus, so that all of them receive the time information at the same time at Port A. By means of the prefabricated bus cables and adapters 7XV5104 the SIPROTEC 4 units can be connected via their IRIG-B interface directly to the sync.-transceiver 7XV5654. The maximum length of the electrical bus when prefabricated cables are used is 20 m. Relevant applications are described in the manual for the sync.-transceiver 7XV5654.

Application

Notes on the IRIG-B bus

In this system solution only the 24 V DC time synchronization inputs of the SIPROTEC 4 units are used (see below). 7XV5105 cables are available for synchronizing the differential protection relays with an additional seconds pulse.

The housings of all bus users must be properly mutually earthed, as otherwise dangerous earth potential currents can flow via the bus cable shield.

Typical applications

The 9-pin male connector of the Y-bus cable S1 always comes from the direction of the radio clock or sync.-transceiver and provides via the 1, 3 or 5 or 10 m cable and the 9-pin male connector to the first and subsequent bus devices. At connector S2 a 9-pin female connector B3 is provided (on a 20 m long cable) to extend the bus. If more than six SIPROTEC 4 units are to be connected to the sync.-transceiver 7XV5654, the adapter 7XV5104-3AA00 splits the connection X1 of the sync.-transceiver into two buses for a maximum of 6 units each. (For typical applications see 7XV5654 manual).

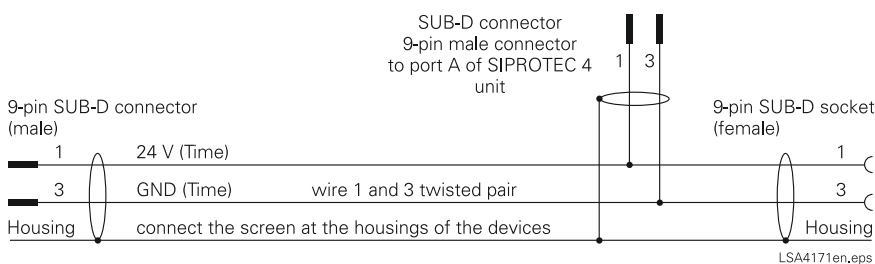

Fig. 13/10

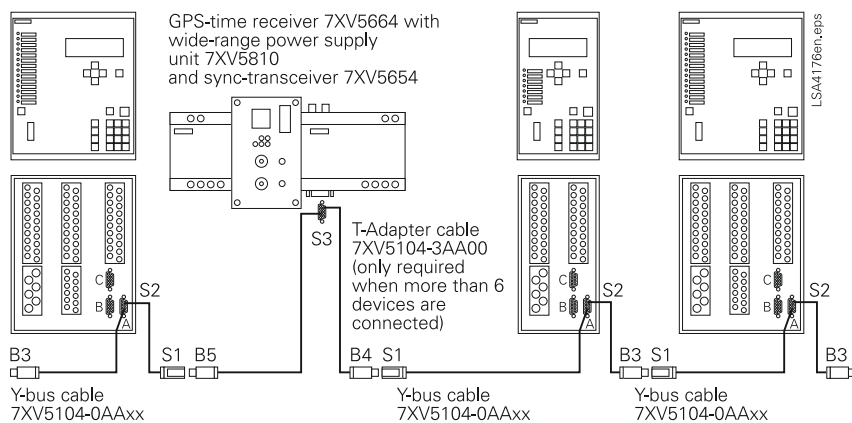

Fig. 13/11

Connection of max. twelve SIPROTEC 4 units to the IRIG-B bus via prefabricated Y-bus cable

Selection and ordering data

Description	Order No.
Y-connection cable IRIG-B / DCF77	7XV5104-0AA□□
Y-connection cable for SIPROTEC 4 unit with IRIG-B / DCF77 connection and bus extension. Copper cable 2-wire, shielded, with 9-pin SUB-D connectors	
Length 1 m	0 1
Length 3 m	0 3
Length 5 m	0 5
Length 10 m	1 0
Extension cable (copper)	
Cable for the bus length extension. Copper cable 2-wire, shielded, with 9-pin SUB-D connector	
Length 10 m	7XV5104-1AA10
Adapter / accessories	7XV5104-□AA00
Adapter cable to sync.-transceiver 7KE6000-8Ax, length 0.3 m, shielded, 2 wires with end sleeves to 9-pin SUB-D connector (female)	2
T-adapter cable to sync.-transceiver 7XV5654-0BA00 Splits connector X1 into 2 buses for max. six SIPROTEC 4 units per bus 9-pin SUB-D connector (male) to 2 x 9-pin SUB-D connector (female) Copper cable 2-wire, shielded (length 0.3 m)	3

7XV5105 Bus Cable for Time Synchronization (for 7SD5 Relays)



Fig. 13/12 Y-cable 7XV5105

Function overview

- Opto-electrical solution for SIPROTEC 4 7SD5 differential protection relays with IRIG-B interface (Port A)
- Direct connection of 7SD5 protection relays via IRIG-B interface to sync.-transceiver 7XV5654
- Transmission of time telegram and seconds pulse at the same time
- 4 orderable cable lengths from 1 m to 10 m
- 4-wire, twisted and shielded cable with 9-pin SUB-D connectors
- Metal plug connector casing of compact dimensions, with fixing screw and strain relief for cable connections
- Max. extent of electrical bus 20 m within building

Description

The evaluation of fault records, operational alarms and fault signals calls for a millisecond-accurate absolute time stamp. The differential protection relays have an internal clock on a quartz basis, by means of which the protection is normally synchronized. In special applications, GPS radio clocks are used to synchronize the 7SD5 differential protection relays with the absolute time. These clocks send a time telegram together with a microsecond-accurate seconds pulse, so that the transmission time in both the sending and the receiving direction can be precisely measured. All the devices in each system are connected in parallel via an electrical bus, so that all devices receive the time information and the seconds pulse at the same time. By means of the prefabricated bus cables 7XV5105, the 7SD5 relays can be connected via their IRIG-B interface (Port A) directly to the sync.-transceiver 7XV5654. The maximum length of the electrical bus when the prefabricated cables are used is 20 m. Relevant applications are described in the manual for the sync.-transceiver 7XV5654.

Application

Notes on the IIRIG-B bus

In this system solution only the 24 V DC time synchronization inputs (Port A) of the SIPROTEC 4 protection relays are used. 2-core 7XV5104 cables are available for time synchronization of the SIPROTEC 4 protection relays without additional seconds pulse.

The housings of all bus users must be properly mutually earthed, as otherwise dangerous earth potential currents can flow via the bus cable shield.

Typical applications

The 9-pin male connector of the Y-bus cable S1 always comes from the direction of the radio clock or sync.-transceiver and provides via the 1, 3, 5 or 10 m cable and the 9-pin male connector the connection to the first and subsequent bus devices. At connector S2 a 9-pin female connector B3 is provided (on a 20 m long cable) to extend the bus. If more than six SIPROTEC 4 units are to be connected to the radio clock, up to 4 sync.-transceivers 7XV5654 can be connected, each with 6 protection relays. (For typical applications see the 7XV5654 manual).

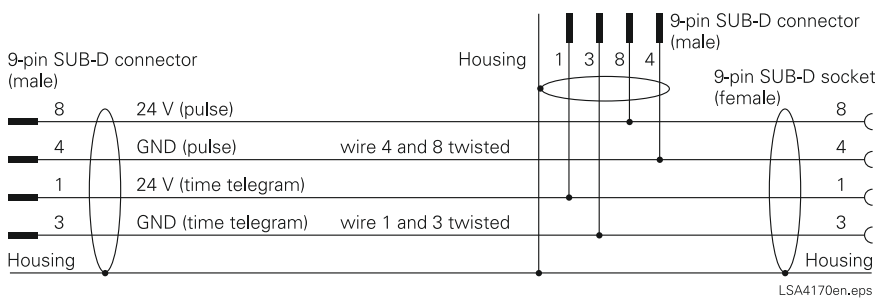

Fig. 13/13

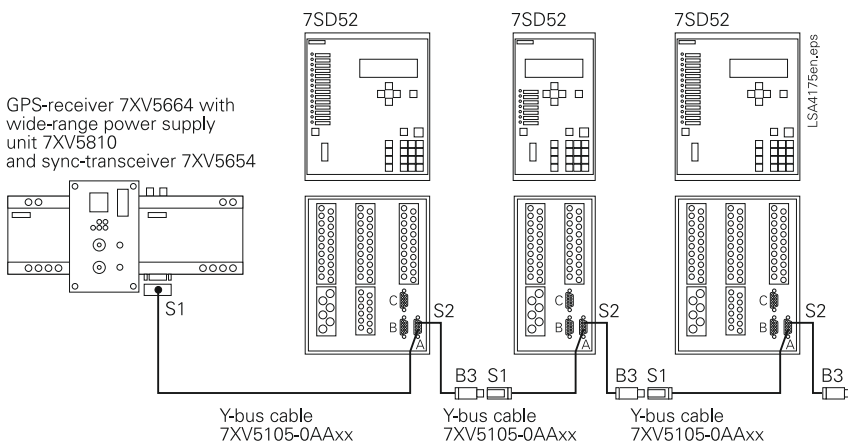

Fig. 13/14

Connection of max. six SIPROTEC 4 protection relays 7SD5 to the IIRIG-B bus via prefabricated Y-bus cable

Selection and ordering data

Description	Order No.
<i>Y-connection cable IIRIG-B / DCF77</i>	7XV5105-0AA□□
Y-connection cable for direct connection of a SIPROTEC 4 differential protection relay with IIRIG-B / DCF77 connection to sync.-transceiver 7XV5654 and bus extension. Copper cable 4-wire, shielded, with 9-pin SUB-D connectors	
Length 1 m	0 1
Length 3 m	0 3
Length 5 m	0 5
Length 10 m	1 0
<i>Extension cable (copper)</i>	
Cable for bus length extension. Copper cable with 4 wires, shielded with 9-pin SUB-D connectors	
Length 10 m	7XV5105-1AA10
<i>Adapter / accessories</i>	
Adapter cable to two sync.-transceivers 7KE6000-8Ax, length 0.3 m shielded, 2 wires with end sleeves to 9-pin SUB-D connector (female)	7XV5105-2AA00

7XV5450 Mini Star-Coupler



Fig. 13/15
Mini star-coupler

Function overview

One optical input and up to 4 optical outputs

- Distance spanned: 1.5 km with 62.5/125 μm multi-mode fiber
- Multiple mini star-couplers cascadable
- RS232 interface for local access
- Baud rate via FO: up to 1.5 Mbaud; Baud rate with RS232: Up to 115 kbaud
- Protocol transparency
- Light idle state: Light ON/light OFF selectable
- Wide-range power supply with self-monitoring function and alarm contact
- Optical ST connectors

Description

The mini star-coupler multiplies an optical signal received at an input for up to four outputs. A signal received at one of the outputs is transmitted via the input interface to a central unit or to an upstream mini star-coupler or converter. As the mini star-coupler does not transmit selectively to individual outputs, the protocols used for data transmission must operate with unique DTE addresses, so all units “hear” the central interrogation, but only the addressed unit answers to the request (e.g. IEC 60870-5-103 or DIGSI).

Data are transmitted in transparent full-duplex mode. An RS232 interface is provided for direct serial communication with DTEs at each mini star-coupler. As long as this interface is in use, the optical input interface to the central unit is blocked.

Cascading mini star-couplers replace the 7XV5300 star coupler.

Application

The mini star-coupler allows SIPROTEC relays to be centrally accessed or remotely interrogated with DIGSI via optical interfaces. The component is cascadable, so that star topologies or ring topologies can be configured. A ring structure ensures that all four outputs are used. The mini star-coupler has a local RS232 interface socket. By connecting a PC to this interface and using the 7XV5100-4 cable, the optical input is disconnected to avoid data collision due to local and remote access concurring at the same time.

Construction

The 7XV5450 mini star-coupler is provided with a snap-on mounting housing for a 35 mm EN 50022 rail. Auxiliary power supplies can be connected via screw-type terminals. The fiber-optic cables are connected by ST connectors. The unit is free of silicone and halogen as well as flame-retardant.

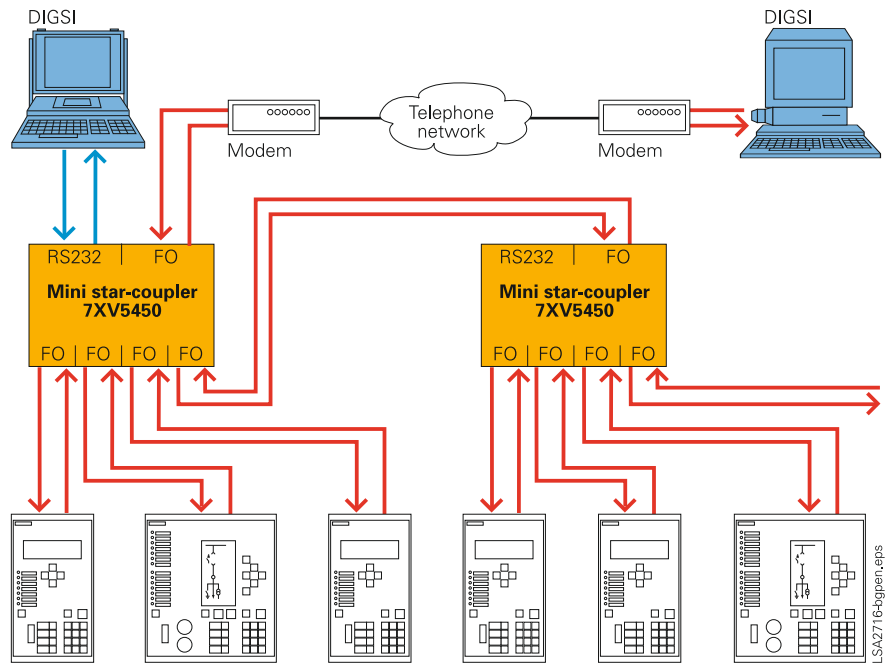

Fig. 13/16 Star topology with mini star-couplers

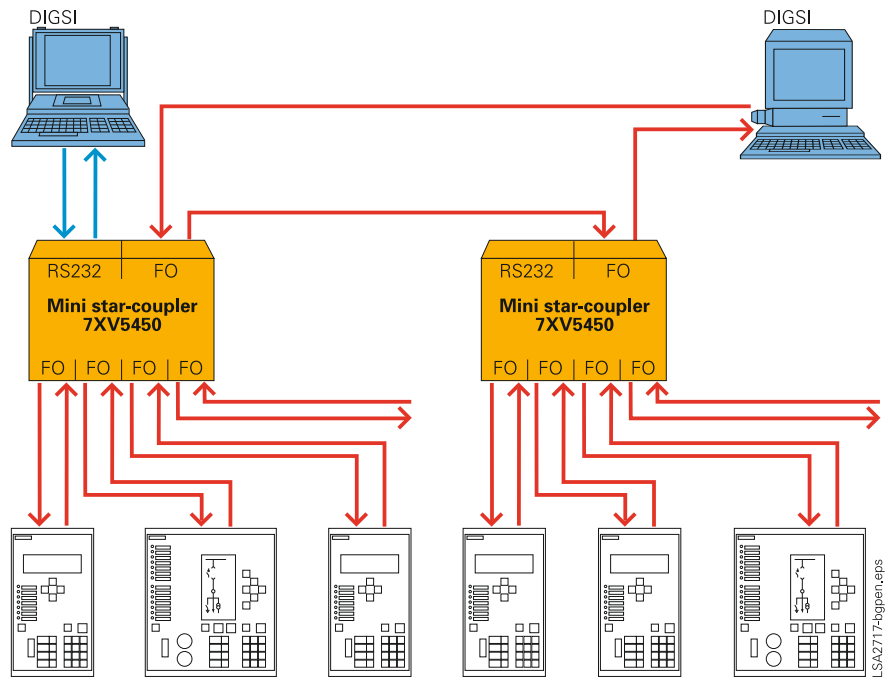

Fig. 13/17 Ring structure with mini star-couplers

Technical data

Rated auxiliary voltage	
24 to 250 V DC and 60 to 230 V AC	± 20 % without switchover
Current consumption	
Approx. 0.25 to 0.4 A	
LEDs	
3 LEDs	
Green	Operating voltage o.k.
Yellow	Receiving data
Yellow	Sending data
Connectors	
Power supply	2-pole Phoenix screw-type terminal
FO cables	Multi-mode fiber with ST connectors
RS232	9-pin SUB-D socket
Alarm contact	2-pole Phoenix screw-type terminal
Light idle state	
Light ON/OFF selectable	By jumpers
Housing	
Plastic housing, EG90, charcoal grey; 90 x 75 x 105 mm (W x H x D) for snap-on mounting on 35 mm EN 50022 rail	

Selection and ordering data

Description	Order No.
7XV5450 mini star-coupler	7XV5450-0BA00
<p>Optical mini star-coupler with plastic housing for snap-on mounting onto 35 mm rail.</p> <p>Rated auxiliary voltage 24 - 250 V DC and 110 - 220 V AC with alarm relay.</p> <p>Connection of up to 4 protection units to a star coupler via FO cable for 62.5 / 125 μm and 850 nm wavelength, max. distance 1.5 km.</p> <p>Connection of PC or modem to a star coupler via FO cable for 62.5 / 125 μm and 850 nm wavelength, max. distance 1.5 km.</p> <p>Connection also by 9-pin RS232 connector.</p> <p>Cascadable</p> <p>Fiber-optic connectors with ST connector</p>	

7XV5461 Two-Channel Serial Optical Repeater (for duplex-mono-mode FO cables)



Fig. 13/18
Optical repeater with
wide-range power supply

Function overview

- Two independent multiplexed 820 nm ports with ST connectors for max. 1.5 km via 50/125 μm and 62.5/125 μm duplex-multi-mode FO cable.
- Data rate of serial ports 1 / 2 from 300 bit/s - 4.096 Mbit/s. Automatic baud rate adjustment to synchronous and asynchronous serial signals; no settings necessary.
- Powerful 1300 nm / 1550 nm port with LC-Duplex connector for distances up to 24 km / 60 km / 100 km / 170 km via 9/125 μm duplex-mono-mode FO cable
- 24 to 250 V DC and 115/230 V AC wide-range power supply with alarm relay.
- Data exchange display by LED
- Integrated commissioning support

Description

The optical repeater transmits serial optical signals over long distances via duplex-mono-mode FO cables. It converts serial optical 820 nm signals at Port 1 and Port 2 in the range of 300 bit/s to 4.096 Mbit/s. Both synchronous and asynchronous signals can be connected. Two independent, serial 820 nm inputs with ST connectors are available, which are multiplexed to Port 3. Two devices with an optical 820 nm interface, for example the 7SD5 / 7SD6 line differential protection relay or the RS232/820 nm 7XV5652 converter, can be connected to Ports 1 and 2 via duplex-multi-mode FO cables for distances of up to 1.5 km. Signal transmission at Port 3 is achieved via the LC-Duplex connector at wavelengths of 1300 nm/1550 nm for connection of a duplex-mono-mode FO cable. For Port 3 there are three options for max. 25 km (1300 nm) / 60 km (1300 nm) and 100 km / 170 km (1550 nm) optical fiber lengths. The device can be connected to all battery voltages and AC supply sources. Loops can be activated for Ports 1 / 2 for commissioning purposes, so that the input signals can be mirrored at the port in question.

Typical applications

The protection relays (for example 7SD5 / 7SD6 differential protection or 7SA52 / 7SA6 distance protection) exchange information via Port 1. Interference-free data exchange is performed via duplex-mono-mode FO cable up to a distance of 170 km. Protection remote control with DIGSI is connected to Port 2 of the repeater via the 7XV5450 mini star-coupler. This port provides the serial connection to the other substation with a PC where DIGSI is installed. The protection relays on the remote substation can be scanned remotely via Port 2. The baud rate is optimally set to 57.6 kbit/s so that there is no difference from local operation. During commissioning and operation, data of the device on the other substation can be changed and read out. Alternatively, it is possible to connect power system control or additional protection data transmission to Port 2. This makes for optimum use of the long-distance optical fiber for two separate serial connections for transmitting data between 300 bit/s and 4.096 Mbit/s.

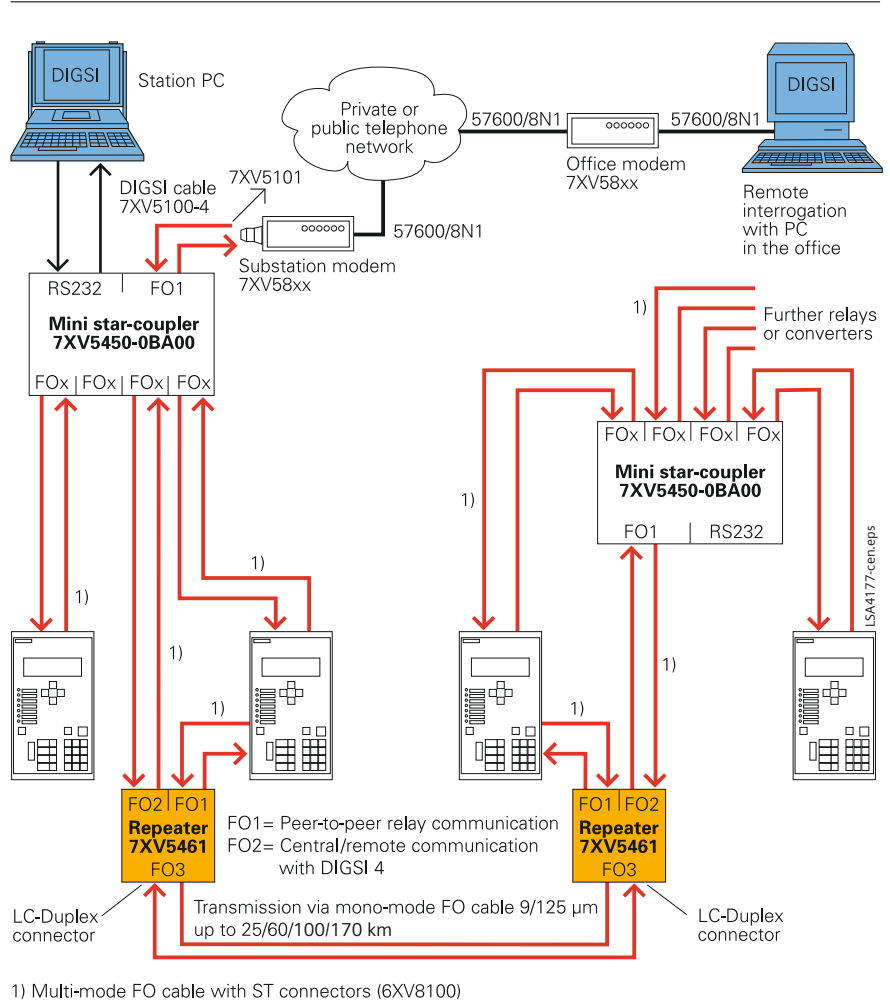

Fig. 13/19 Transfer of protection data and remote control of a substation via an optical long-distance connection

Technical data

Connections	
Ports 1 / 2	ST connector for 820 nm for 50/125 µm and 62.5/125 µm multi-mode FO cable
Port 3	LC-Duplex connector for 1300 nm/1550 nm for 9/125 µm mono-mode FO cable
Screw-type terminals	2-pole screw-type terminals for auxiliary voltage supply 3-pole make/break contact for alarm relay
Housing	
188 x 56 x 100 mm aluminum housing for mounting on 35 mm DIN rail to EN 50032. Weight 0.8 kg. Degree of protection acc. to EN 60529: IP41	
Power supply	
Wide range 24 to 250 V DC without connector jumpers, 115 / 230 V AC	
Displays	
4 LEDs	
Green	Power supply
Red	Alarm relays
2 yellow	Data exchange

Selection and ordering data

Description	Order No.
<u>7XV5461 two-channel serial optical repeater (for duplex-mono-mode FO cables)</u>	<u>7XV5461-0B□00</u>
Connection of two serial optical inputs with ST connector for 62.5/125 μm multi-mode FO cable up to 1.5 km, from 300 bit/s to 4.096 Mbit/s 24 to 250 V DC, 115/230 V AC wide-range power supply Fault relay and LED for operational and fault display	
Optical 1300 nm output with LC-Duplex connector for 9/125 μm mono-mode FO cable for distances up to 24 km (permissible path attenuation 13 dB)	G
Optical 1300 nm output with LC-Duplex connector for 9/125 μm mono-mode FO cable for distances up to 60 km (permissible path attenuation 29 dB)	H ¹⁾
Optical 1550 nm output with LC-Duplex connector for 9/125 μm mono-mode FO cable for distances up to 100 km (permissible path attenuation 29 dB)	J ¹⁾
Optical 1550 nm output with LC-Duplex connector for 9/125 μm mono-mode FO cable for distances up to 170 km (permissible path attenuation 43 dB)	M ¹⁾

1) When ordering options H/J an additional attenuator is required if the devices are used for distances < 20 km

7XV5461 Two-Channel Serial Optical Repeater (for 1 mono-mode FO cable)



Fig. 13/20
Optical repeater with integrated 1300 nm/1550 nm wave length multiplexer for one single mono-mode FO-cable

Function overview

- Two independent multiplexed 820 nm Ports 1/2 with ST connectors for max. 1.5 km via 50/125 μm and 62.5/125 μm multi-mode FO cable.
- Data rate of serial Ports 1/2 from 300 bit/s – 4.096 Mbit/s. Automatic baud rate adjustments to synchronous and asynchronous serial signals; no settings necessary.
- Powerful 1300 nm/1550 nm port with LC-single connector for distances up to 40 km via one 9/125 μm mono-mode FO cable
- 24 to 250 V DC and 115/230 V AC wide-range power supply with alarm relay.
- Data exchange display by LED
- Integrated commissioning support

Description

The optical repeater exchanges serial optical signals over long distances via only one single mono-mode FO cable. It converts serial optical 820 nm signals at Port 1 and Port 2 in the range 300 bit/s – 4.096 Mbit/s to 1300/1550 nm for one mono-mode FO cable. Both synchronous and asynchronous signals can be connected at Port 1/2. Two independent, serial 820 nm inputs with ST connectors are available, which are multiplexed to Port 3. Two devices with an optical 820 nm interface, for example the 7SD5/7SD610 line differential protection relay or the RS232/820 nm 7XV5652 converter, can be connected to Ports 1 and 2 via multi-mode FO cables for distances of up to 1.5 km. Signal transmission at Port 3 is achieved via the single LC connector at wavelengths of 1300 nm/1550 nm for connection of mono-mode FO cable up to 40 km. The device can be connected to DC battery voltages and AC supply sources. Loops can be activated for Port 1/2 for commissioning purposes, so that the input signals can be mirrored at each port to support commissioning of the fiber optical links.

Application

Until now, two FO cables are required for the bidirectional transmission of protection signals. With the repeater with integrated wavelength multiplexer one FO cable is sufficient: Two protection relays e.g. 7SD52/7SD610 differential protection or 7SA52/7SA6 distance protection, exchange information via Port 1 (po1). Interference-free data exchange is performed via one optical mono-mode FO cable up to a max. distance of 40 km. Protection remote control with DIGSI is connected to Port 2 of the repeater via a 7XV5450 mini star-coupler. This port provides the serial connection to the other substation with a PC on which DIGSI is installed. In this way, the remote protection devices can be remotely interrogated via Port 2. The baud rate is optimally set to 57.6 kbit/s so that there is no difference from local operation. The data of the devices on the other substation can be changed or read out during commissioning and operation. Alternatively, it is possible to connect substation control devices, RTU or additional protection data transmission to Port 2. This makes for optimum use of the long-distance optical cable for two separate serial connections for transmitting serial data between 300 bit/s and 4.096 Mbit/s.

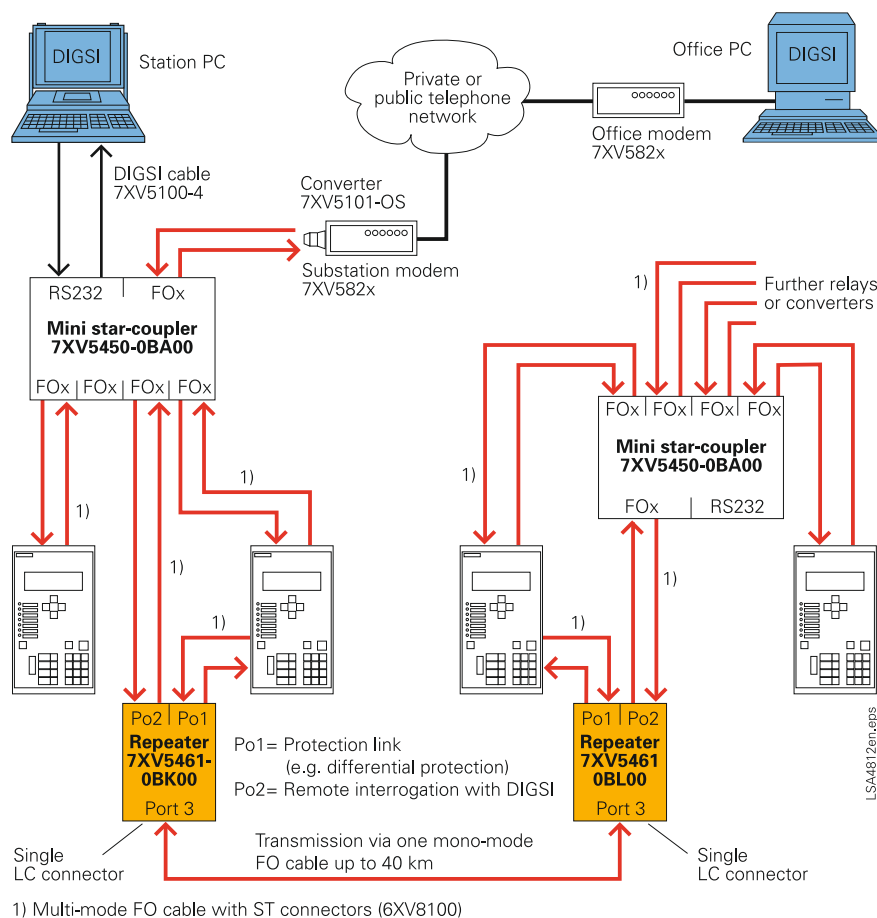

Fig. 13/21

Transfer of protection data signals and remote control/integration via one mono-mode FO cable
(Note: Devices 7XV5461-0BK00 and 7XV5461-0BL00 must be used in pairs)

Technical data

Connections	
Ports 1 / 2	ST connector for 820 nm for 50/125 µm and 62.5/125 µm multi-mode FO cable
Port 3	LC-single connector for 1300 nm/1550 nm for 9/125 µm mono-mode FO cable
Screw-type terminals	2-pole screw-type terminals for auxiliary voltage supply 3-pole make/break contact for alarm relay
Housing	
Interference-free 188 x 56 x 120 mm metal housing for mounting on 35 mm DIN rail to EN 50032. Weight 0.8 kg. Degree of protection acc. to EN 60529: IP41	
Power supply	
Wide range 24 to 250 V DC or 115 / 230 V AC	
Displays	
4 LEDs	
Green	Power supply
Red	Alarm relays
2 yellow	Data exchange indication

Selection and ordering data

Description	Order No.	
<i>Two-channel serial optical repeater with integrated wavelength multiplexer</i>	7XV5461-0B□00	
Connection of two serial optical inputs with ST connector for 62.5/125 μm multi-mode FO cable up to 1.5 km, from 300 bit/s – 4.096 Mbit/s 24 – 250 V DC, 115/230 V AC wide-range power supply Alarm relay and LED for operational and fault display	↑	
Optical 1550 nm output with LC-single connector for 9/125 μm mono-mode FO cable for distances up to 40 km (permissible path attenuation 25 dB)		K
Optical 1300 nm output with LC-single connector for 9/125 μm mono-mode FO cable for distances up to 40 km (permissible path attenuation 25 dB)		L

7XV5461 Two-Channel Serial Optical Repeater (for duplex-multi-mode FO cables)



Fig. 13/22
Optical repeater with
wide-range power supply

Function overview

- Two independent multiplexed 820 nm ports with ST connectors for a max. of 1.5 km via 50/125 μm and 62.5/125 μm duplex-multi-mode FO cable.
- Data rate of serial Ports 1 / 2 from 300 bit/s - 1.5 Mbit/s. Automatic baud rate adjustment to synchronous and asynchronous serial signals; no settings necessary.
- Powerful 1300 nm port with LC-Duplex connector for distances up to 4 km / 8 km via 50/125 μm / 62.5/125 μm duplex-multi-mode FO cable
- 24 to 250 V DC and 115/230 V AC wide-range power supply with alarm relay.
- Data exchange display by LED
- Integrated commissioning support with test loop feature

Description

The optical repeater transmits serial optical signals over long distances via duplex-multi-mode FO cables. It converts serial optical 820 nm signals at Port 1 and Port 2 in the range 300 bit/s - 1.5 Mbit/s to 1300 nm for duplex-multi-mode fiber cables. Both synchronous and asynchronous signals can be connected. Two independent, serial 820 nm inputs with ST connectors are available, which are multiplexed to Port 3. One transmit (Tx) and one receive (Rx) signal is supported (no RTS/CTS handshake signals). Two devices with an optical 820 nm interface, for example the 7SD52 / 7SD610 line differential protection relay or the RS232/820 nm 7XV5652 converter, can be connected to Ports 1 and 2 via duplex-multi-mode FO cables for distances of up to 1.5 km. Signal transmission at Port 3 is achieved via the LC-Duplex connector at wavelengths of 1300 nm for connection of a duplex-multi-mode FO cable. For Port 3 there are two options for a max. of 4 km (1300 nm) and 8 km (1300 nm) optical fiber lengths. The device can be connected to all battery voltages and AC supply sources. Loops can be activated for Ports 1 / 2 for commissioning purposes, so that the input signals can be mirrored at the port in question.

Typical applications

Two protection relays (for example 7SD52/7SD610 differential protection or 7SA52/7SA6 distance protection) exchange information via Port 1. Interference-free data exchange is performed via optical duplex-multi-mode FO cable up to a distance of 4/8 km. Protection remote control with DIGSI is connected to Port 2 of the repeater via 7XV5450 mini star-coupler. This port provides the serial connection to the other substation with a PC where DIGSI is installed. The protection relays on the remote substation can be interrogated remotely via Port 2. The baud rate is optimally set to 57.6 kbit/s so that there is no difference from local operation. During commissioning and operation, the data of the device in the other substation can be changed and read out. Alternatively, it is possible to connect a substation control system or additional protection data transmission to Port 2. This makes for optimum use of the long-distance optical fiber for two separate serial connections for transmitting data between 300 bit/s and 4.096 Mbit/s.

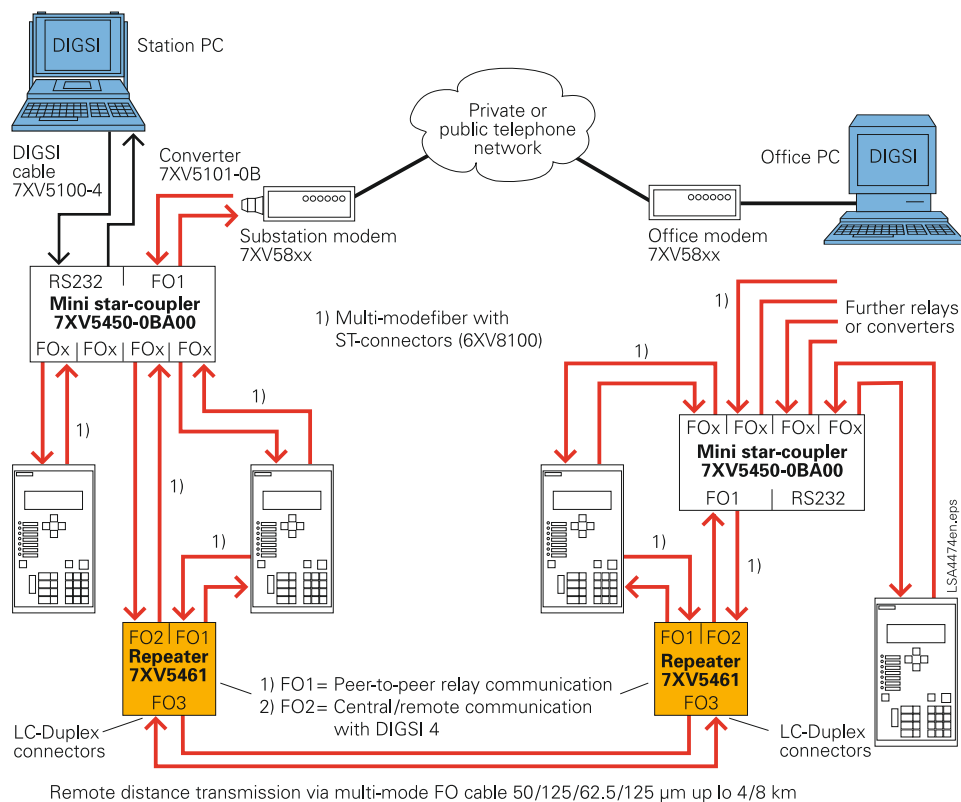

Fig. 13/23

Transfer of protection data and remote control of a substation via an optical long-distance connection

Technical data

Connections

Ports 1 / 2	ST connector for 820 nm for 50/125 μm and 62.5/125 μm multi-mode FO cable
Port 3	LC-Duplex connector for 1300 nm for 50/125 μm / 62.5/125 μm multi-mode FO cable
Screw-type terminals	2-pole screw-type terminals for auxiliary voltage supply 3-pole make/break contact for alarm relay

Housing

188 x 56 x 100 mm aluminum housing for mounting on 35 mm DIN rail to EN 50032.
Weight 0.8 kg. Degree of protection to EN 60529: IP41

Power supply

Wide range 24 to 250 V DC without switchover 115 / 230 V AC

Displays

4 LEDs	
Green	Power supply
Red	Alarm relays
2 yellow	Data exchange

Selection and ordering data

Description	Order No.	
<u>Two-channel serial optical repeater (for duplex multi-mode FO cables)</u>	<u>7XV5461-0B□00</u>	
Connection of two serial optical inputs with ST connector for 62.5/125 μm multi-mode FO cable up to 1.5 km, from 300 bit/s to 1.5 Mbit/s 24 to 250 V DC, 115/230 V AC wide-range power supply Fault relay and LED for operational and fault display		
Optical 1300 nm output with LC-Duplex connector for 50/125 μm / 62.5/125 μm multi-mode FO cable for distances up to 4 km (permissible path attenuation 13 dB)		<i>F</i>
Optical 1300 nm output with LC-Duplex connector for 50/125 μm / 62.5/125 μm multi-mode FO cable for distances up to 8 km (permissible path attenuation 29 dB)		<i>E</i>

7XV5550 Active Mini Star-Coupler



Fig. 13/24
Active mini star-coupler

Function overview

One optical input and 4 optical outputs or one RS485 input and 5 optical outputs

- RS232 interface for local access
- RS485 interface for bus structure
- Baud rate and data format can be set independently for each port
- Baud rate 1200 baud – 115 kbaud
- Data format 8N1, 8N2, 8E1
- Max. distance: 1.5 km with 62.5/125 μ m multi-mode FO cable
- Light idle state:
Light ON/light OFF selectable
- Wide-range power supply with self-supervision function and alarm contact
- Optical ST connectors

Description

Five optical ports allow the active mini star-coupler to centrally or remotely communicate with devices with serial interfaces using different baud rates and data formats. Using a simple ASCII sequence, only one of the available output channels is switched to a transparent full duplex operation. The active mini star-coupler can be used with any terminal program or for SIPROTEC protection relays with the DIGSI operating program. Each of the input and output channels can be parameterized independently to the device attached by adjustable baud rates and data formats or as input or output ports. For communication with more than 5 devices, the active mini star-coupler can be cascaded together with an RS485 bus in half-duplex mode with further devices.

Please note:

The 7XV5450 passive mini Star-coupler is recommended for controlling several SIPROTEC 3 or SIPROTEC 4 devices with DIGSI or for communication by a remote control system.

Application

Using the integrated optical interfaces of the active mini star-coupler, data transmission for the protection relays V1/2, SIPROTEC 3 or 4 can be performed centrally or remotely with DIGSI. When using the RS485 bus structure each active mini star-coupler provides five optical outputs. An RS232 interface is available for local operation with a notebook. The control PC (directly or via modem) always operates with the same data format, while the interfaces to the different protection relays using other formats are adapted accordingly. For V1/2 protection relays, a 7XV5101-0A plug-in connector module is required for each relay and each relay must be connected to a separate port.

Construction

The active mini star-coupler is provided with a snap-on mounting housing for a 35 mm EN 50022 rail. Auxiliary power supplies can be connected via screw-type terminals. The fiber-optic cables are connected by ST connectors. The unit is free of silicone and halogen as well as flame-retardant.

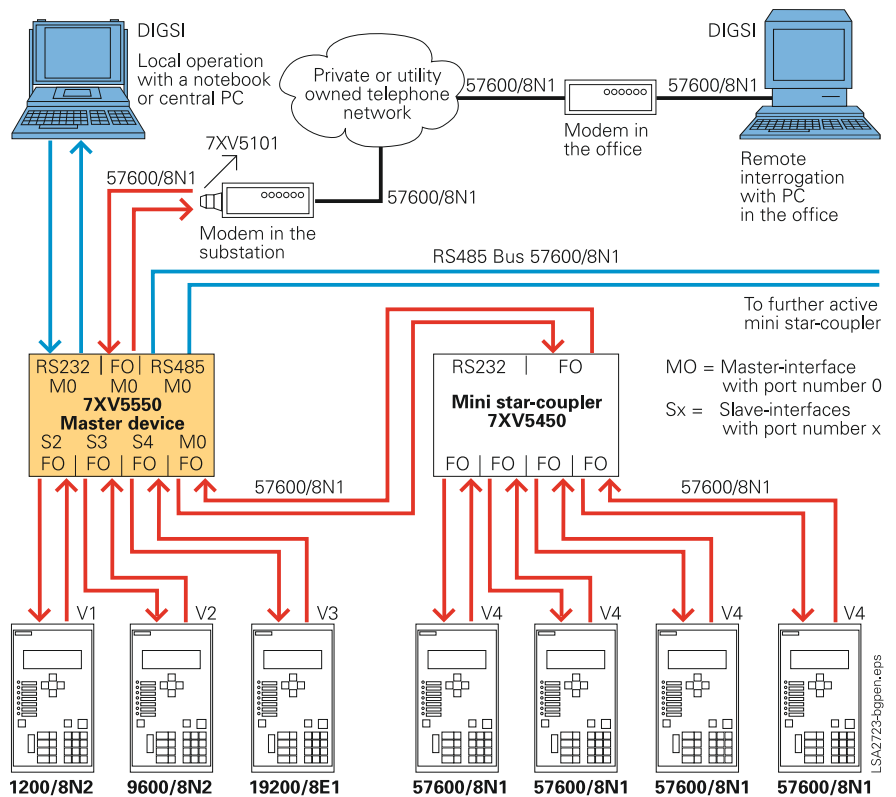

Fig. 13/25

Technical data

Rated auxiliary voltage	
24 to 250 V DC and 60 to 230 V AC	± 20 % without switchover
LEDs	
3 LEDs	
Green	Operating voltage o.k.
Yellow	Receiving data
Yellow	Sending data
Connectors	
Power supply	2-pole Phoenix screw-type terminal
FO connections	820 nm ST connectors
RS232	9-pin SUB-D socket
RS485	2-pole Phoenix screw-type terminal
Alarm contact	2-pole Phoenix screw-type terminal
Light idle state	
Light ON/OFF selectable	By jumpers
Housing	
Plastic housing, EG90, charcoal grey; 90 x 75 x 105 mm (W x H x D) for snap-on mounting onto 35 mm EN 50022 rail	

Selection and ordering data

Description	Order No.
7XV5550 active mini star-coupler	7XV5550-0BA00
Optical active mini star-coupler with plastic housing for snap-on mounting onto 35 mm rail.	
Rated auxiliary voltage 24 - 250 V DC and 110 - 230 V AC with alarm relay.	
Connection of up to 4 protection units to an active mini star-coupler via FO cable for 62.5 / 125 µm and 850 nm wavelength, max. distance 1.5 km.	
Connection of PC or modem to an active mini star-coupler via FO cable for 62.5 / 125 µm and 850 nm wavelength, max. distance 1.5 km.	
Connection also by 9-pin RS232 connector.	
Cascadable	
Fiber-optic connectors with ST connector	

7XV5650/5651 RS485 – FO Converter



Fig. 13/26
RS485 – FO converter

Function overview

- Baud rates 9.6 – 115 kbaud
- Topologies:
7XV5650: Optical star
7XV5651: Optical line, RS485 bus
- Protocol transparency
- Light idle state:
Light ON/light OFF selectable
- Distance: 1.5 km with 62.5/125 μm FO cable
- 120 Ω terminator for RS485 bus, activated/deactivated by DIP switch
- Wide-range power supply with self-supervision function and fault output relay

Description

The RS485 – FO converter allows up to 31 devices to be connected with a bus-capable electrical RS485 interface. It provides an optical link-up to a central unit or a star coupler. The converter has been designed for use in substations for interference-free transmission of serial data with rates between 9.6 and 115.2 kbaud by multi-mode FO cable.

The 7XV5651 converter is designed to act as a T-coupler, data can be distributed in a line structure system, forming a basis for building up cost-effective optical bus systems.

The version 7XV5650 is designed for star topology via fiber-optic connection.

Application

The converters can be used in an optical line structure or in an optical star structure. Application in optical line structure allows relays to be connected interference-free via fiber-optic cables; for indoor installation, a cost-effective RS485 bus can be used.

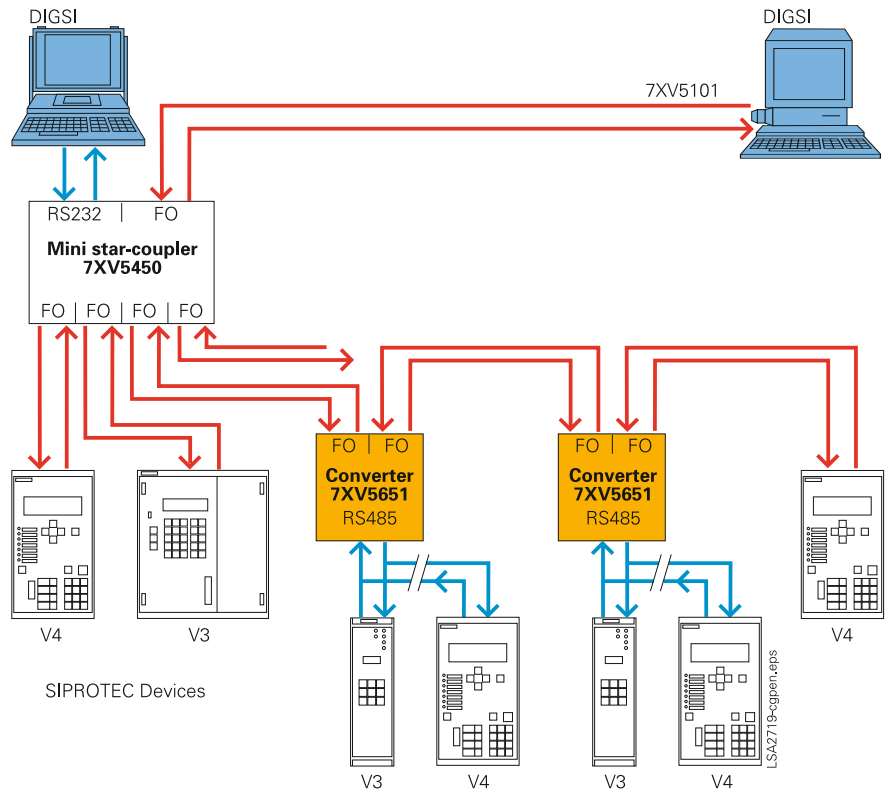

Fig. 13/27 Optical line structure with connected RS485 interfaces

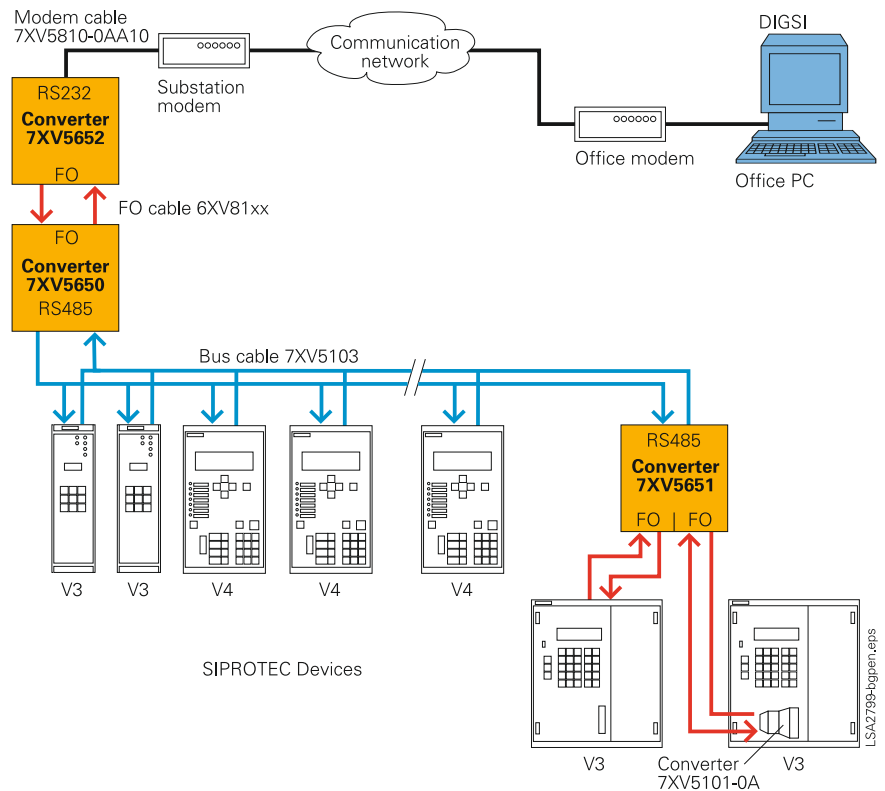

Fig. 13/28 Connection of optical interfaces to an RS485 bus

Application

Several units equipped with FO interface and DIGSI or IEC 60870-5-103 protocol can be connected to an existing RS485 bus structure.

Within one system, the data format and the baud rate have to be set to the same values.

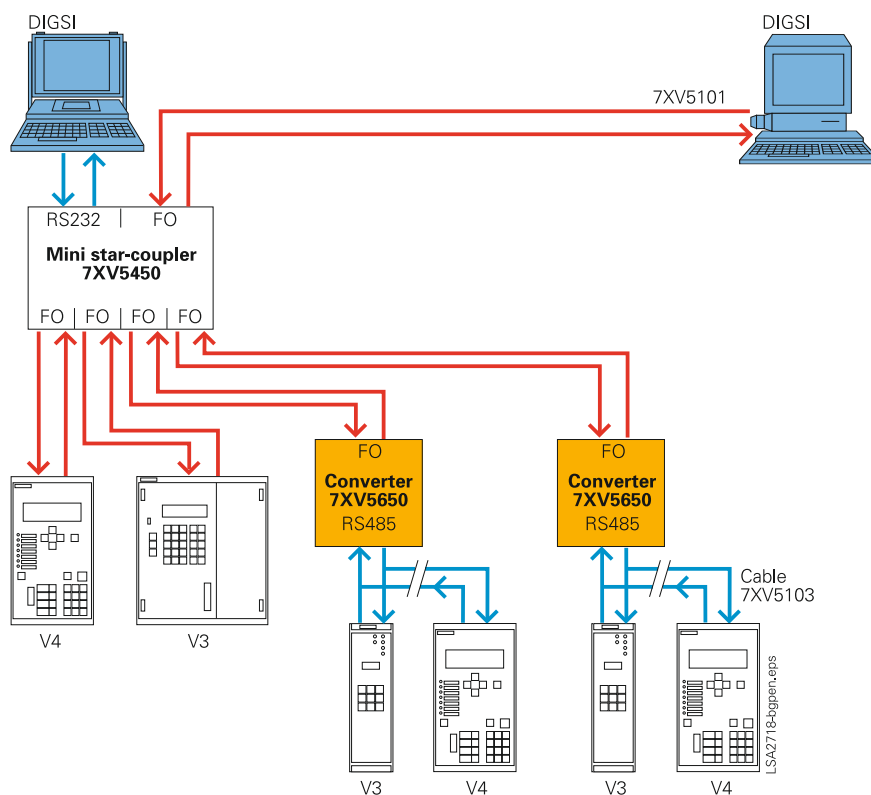

Fig. 13/29 Optical star structure with connected RS485 interfaces

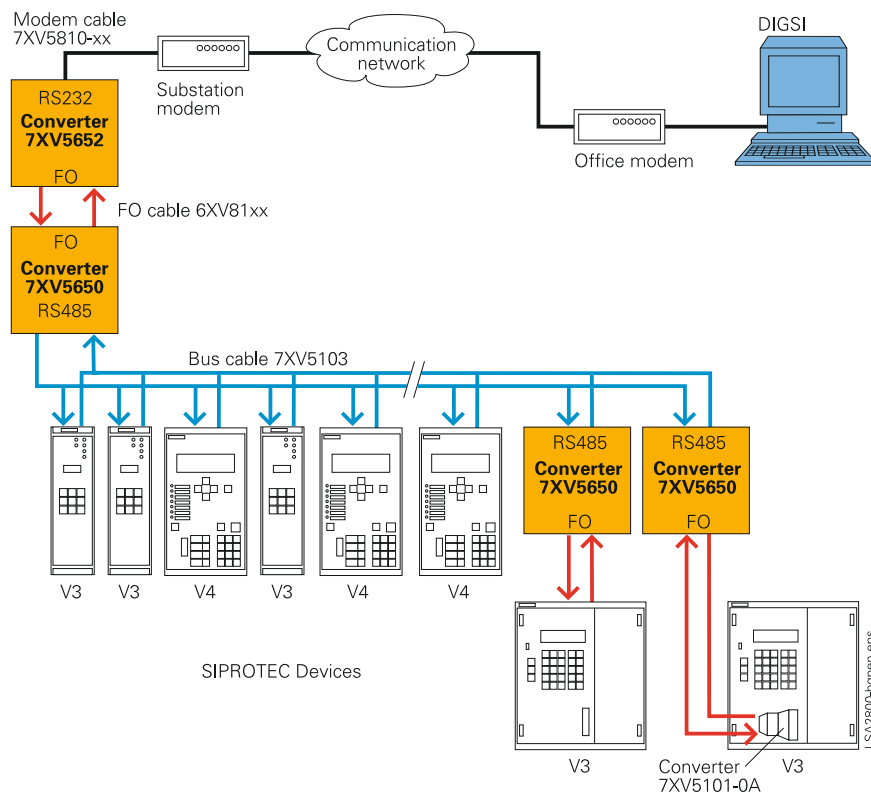

Fig. 13/30 Connection of optical interfaces to an RS485 bus

Construction

The converter is provided with a snap-on mounting housing for a 35 mm EN 50022 rail. Auxiliary power supplies can be connected via screw-type terminals.

The fiber-optic cables are connected by ST connectors. The unit is free of silicone and halogen as well as flame-retardant.

Technical data

Rated auxiliary voltage	
24 to 250 V DC and 60 to 230 V AC	± 20 % without switchover
Current consumption	
Approx. 0.2 to 0.3 A	
LEDs	
2/3 LEDs	
Green	Operating voltage o.k.
Yellow	Receiving data on FO channel 1
Yellow	Receiving data on FO channel 2 (7XV5651 only)
Connectors	
Power supply	2-pole Phoenix screw-type terminal
FO	820 nm ST connector
RS485	9-pin SUB-D socket 2-pole Phoenix screw-type terminal
Alarm contact	2-pole Phoenix screw-type terminal
Light idle state	
Light ON/OFF selectable	
Housing	
Plastic housing, EG90, charcoal grey; 90 x 75 x 105 mm (W x H x D) for snap-on mounting onto 35 mm EN 50022 rail	

Selection and ordering data

Description	Order No.
7XV565 RS485 – FO converter	7XV565□-0BA00
Converter with 1 RS485 interface and 2 FO cables for transmission rates from 9.6 kbaud to 115 kbaud With plastic housing for snap-on mounting on 35 mm rail. Rated auxiliary voltage 24 - 250 V DC and 110 - 230 V AC with alarm contact. Connection of units with RS485 interface by 9-pin SUB-D connector or screw-type terminals. Connection of PC or modem to a star coupler via FO cable for 62.5/125 μm or 50/125 μm and 850 nm wavelength. Fiber-optic connectors: FO 820 nm with ST connector	↑
1 channel	0
2 channels	1

7XV5652 RS232 – FO Converter



Fig. 13/31
RS232 – FO converter

Function overview

- Serial baud rates up to 115 kbaud
- No setting of baud rate necessary
- Protocol transparency
- Light idle state: Light ON / light OFF selectable
- Distance: 3 km with 62.5/125 μm FO cable
- Wide-range power supply with self-supervision function and alarm contact
- Supports the serial TxD and RxD lines of the RS232 interface.
No handshake lines supported

Description

The RS232 – FO converter is used to convert serial RS232 signals to FO transmission signals in full duplex mode. It has one FO channel for transmission and one for receiving, as well as a protected RS232 interface rated to withstand 2 kV discharges, thus allowing direct connection to the serial system interface of SIPROTEC relays. It is designed to be used in substations for isolated, interference-free transmission of serial signals to a central unit, a star coupler or a PC.

The converter supports the conversion of serial TxD (transmit) and RxD (receive) signals to an optical output. No handshake signals are supported.

Application

With the serial RS232 – FO converter, an existing RS232 interface at a SIPROTEC relay can be upgraded to an optical 820 nm interface to connect the relay with further optical components for central and remote interrogation with DIGSI. Another application is the interfacing between a line differential relay and a communication network, which provides electrical RS232 inputs. The connection between the communication room, where the converter is located, and the relay is executed without interference via multi-mode FO cables (Fig. 13/32).

Construction

The converter is provided with a snap-on mounting housing for a 35 mm EN 50022 rail. Auxiliary power supplies can be connected via screw-type terminals. The fiber-optic cables are connected by ST connectors. The unit is free of silicone and halogen as well as flame-retardant.

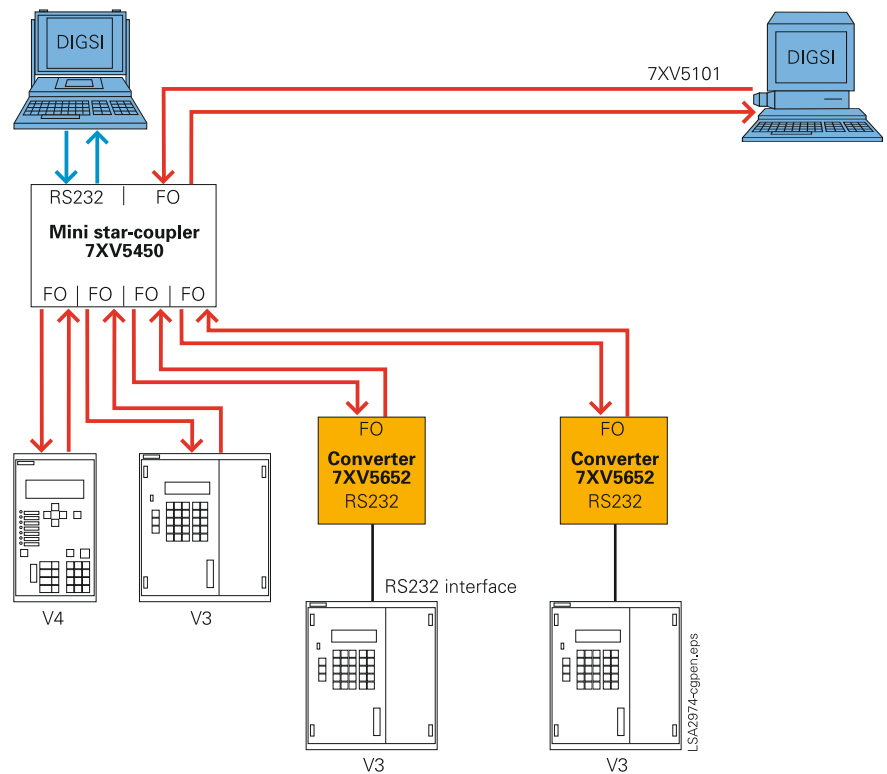

Fig. 13/32 Remote interrogation with the RS232 interface

Technical data

Rated auxiliary voltage	
24 to 250 V DC and 60 to 230 V AC	± 20 % without switchover
Current consumption	
Approx. 0.1 to 0.2 A	
LEDs	
1 LED Green	Operating voltage o.k.
Connectors	
Power supply	2-pole Phoenix screw-type terminal
FO cables	820 nm ST connectors
RS232	9-pin SUB-D socket
Alarm contact	2-pole Phoenix screw-type terminal
Light idle state	
Light ON/OFF selectable	
Housing	
Plastic housing, EG90, charcoal grey; 90 x 75 x 105 mm (W x H x D) for snap-on mounting onto 35 mm EN 50022 rail	

Selection and ordering data

Description	Order No.
7XV5652 RS232 – FO converter	7XV5652-0BA00
<p>For conversion of FO to RS232 (V.24) signals up to 115 kbaud With plastic housing for snap-on mounting on 35 mm rail Rated auxiliary voltage 24 - 250 V DC and 110 - 230 V AC with alarm contact. Connection of units with RS232 interface by 9-pin SUB-D connector Connection of PC, star coupler, modem via FO cable for 62.5/125 µm and 850 nm wavelength Fiber-optic connectors: FO 820 nm with ST connector</p>	

7XV5653 Two-Channel Binary Transducer



Fig. 13/33
Binary transducer

Description

The transducer registers binary information from contacts via two binary inputs and forwards it interference-free to the second transducer via fiber-optic cable. The indications/signals received by this second transducer are put out via its contacts. The two contacts can be used as trip contacts. The transducer is equipped with independent and bidirectional binary inputs (2) and contact outputs (2).

The transducer has been designed for application in substations. Highly reliable, telegram-backed serial data transmission is used between the transducers. Transmission errors and failure of the data link are indicated via an alarm contact, i.e. a permanent supervision of power supply and the datalink is integrated in the transducer.

Function overview

- 2 isolated binary inputs (24 to 250 V DC)
- 2 isolated trip contacts
- Fast remote trip via a serial point-to-point link of up to 115 kbaud/12 ms.
- Telegram-backed interference-free transmission via FO cable
- Permanent data link supervision and indication
- Distance of approx. 3 km via multi-mode FO cable 62.5/125 μm
- Transmission of up to 170 km via mono-mode FO cable with 7XV5461 repeater
- Transmission via communication networks and leased lines and pilot wires with 7XV5662-0AC01 communication converters
- Wide-range power supply with self-supervision function and alarm relay

Application

The bidirectional transducer registers binary information at two binary inputs and forwards it via fiber-optic cable to a second transducer, which outputs the signals via contacts. Distances of about 3 km can be covered directly via multi-mode fiber-optic cables. The 7XV5461 repeater is available for distances up to 170 km via mono-mode fiber-optic cable. (Fig. 13/34) With two transducers connected to 7XV5461, up to four binary signals can be transferred. One application is phase-selective intertripping.

With a communication converter, the transducer can be interfaced to different kinds of communication links. Modern N x 64 kbit/s digital networks can be used. Existing pilot wires can also be used for data exchange between the relays. The data to be exchanged includes directional signals, intertrip signals and other information.

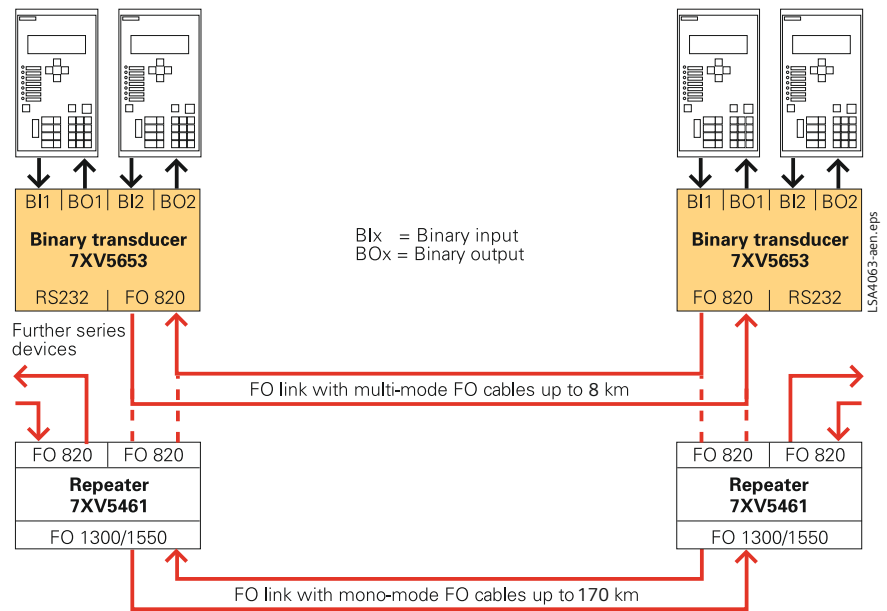
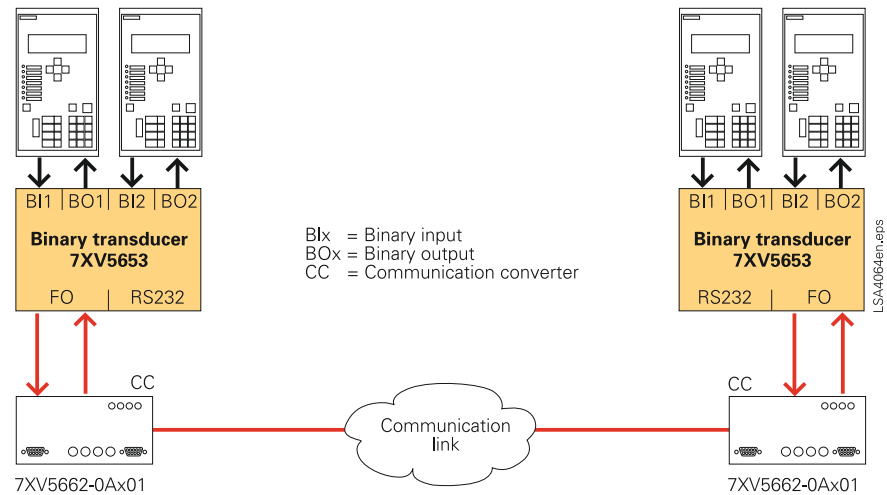

Fig. 13/34

Construction

The converter is provided with a snap-on mounting housing for a 35 mm EN 50022 rail. Auxiliary power supplies can be effected via screw-type terminals. The fiber-optic cables are connected by ST connectors. The unit is free of silicone and halogen as well as flame-retardant.



- X = A: Options for the communication link:
G.703.1, X.21 interface to a communication network
- X = C: pilot-wire cable up to 10 km
- X = D: G.703.6 (E1/T1) interface to a communication network

Fig. 13/35

Technical data

Rated auxiliary voltage	
24 to 250 V DC and 60 to 230 V AC	± 20 % without switchover
Current consumption	
Approx. 0.15 to 0.25 A	
LEDs	
6 LEDs	
1 x green	Operating voltage o.k.
2 x yellow	Contact unit ½ active
2 x yellow	Command relay ½ active
1 x red	Alarm
Connectors	
Power supply	2-pole Phoenix screw-type terminal
FO connection	820 nm FSMA screw-type connector
FO connection	820 nm ST connector
Binary inputs	4-pole Phoenix screw-type terminal
Alarm contact	2-pole Phoenix screw-type terminal
Light idle state	
Light ON/OFF selectable	
Housing	
Plastic housing, EG90, charcoal grey; 90 x 75 x 105 mm (W x H x D) for snap-on mounting onto 35 mm EN 50022 rail	

Selection and ordering data

Description	Order No.
7XV5653 two-channel binary transducer	7XV5653-0BA00
Binary signal transducer	
Plastic housing, for snap-on mounting onto 35 mm EN 50022 rail	
Rated auxiliary voltage 24 to 250 V DC and 110 to 230 V AC with alarm relay, 2 binary inputs, 2 trip contacts, 1 alarm relay with potential-free contact for pilot-wire supervision	
Connection to a second transducer via FO cable for 62.5 / 125 µm and 820 nm wavelength (ST connectors). Max. distance 3 km.	
Connection to a second transducer via a communication system with a RS232 interface, 9-pin SUB-D connector, baud rate settable by DIP-switches	
Fiber-optic connectors with ST connector	

7XV5655-0BB00

Ethernet Modem for Substations



Fig. 13/36
Front view of the Ethernet modem

Function overview

- RS232 interface for data transfer and configuration of the modems
- Serial data rate and data format (RS232/RS485) for the terminal devices is selectable from 2.4 kbit/s up to 57.6 kbit/s with data format 8N1, 8E1
- FO interface for serial data transfer
- 10 Mbit Ethernet interface (LAN) to the 10/100 Mbit Ethernet network
- Increased security with password protection and IP address selection is possible
- Exchange of serial data via Ethernet network between two Ethernet modems (e.g. DIGSI protocol, IEC 60870-5-103 protocol)
- Exchange of serial protocols via Ethernet without gaps in the telegram structure

Description

A control PC and protection relays can exchange serial data via an Ethernet network using two Ethernet modems 7XV5655. Connection to the Ethernet modem is in each case made via the asynchronous serial interface of the terminal devices. In the modem the serial data is packed into the secure IP protocol as information data, and is transferred between the modems using the Ethernet connection. Conformity with the standard and gap-free transmission of serial DIGSI or IEC 60870-5-103/101 telegrams (frames) via the network is ensured by the modem which receives the serial telegram communication and packs the serial IEC telegrams into blocks for communication via the Ethernet. Data is transmitted in full duplex mode, the serial handshake is not supported. Connection is set up between the IP address of the dialing modem in the office and the IP address of the answering modem in the substation and is configured prior to dial up with DIGSI by means of AT commands via the RS232 interface.

The substation modem may be configured to have password protection, and provides the additional security feature, permitting access only from defined IP addresses, e.g. only that of the office modem. The modem is accessed with DIGSI Remote like a normal telephone modem with the exception that instead of telephone numbers, IP addresses are assigned by the network administrator for each modem.

Application

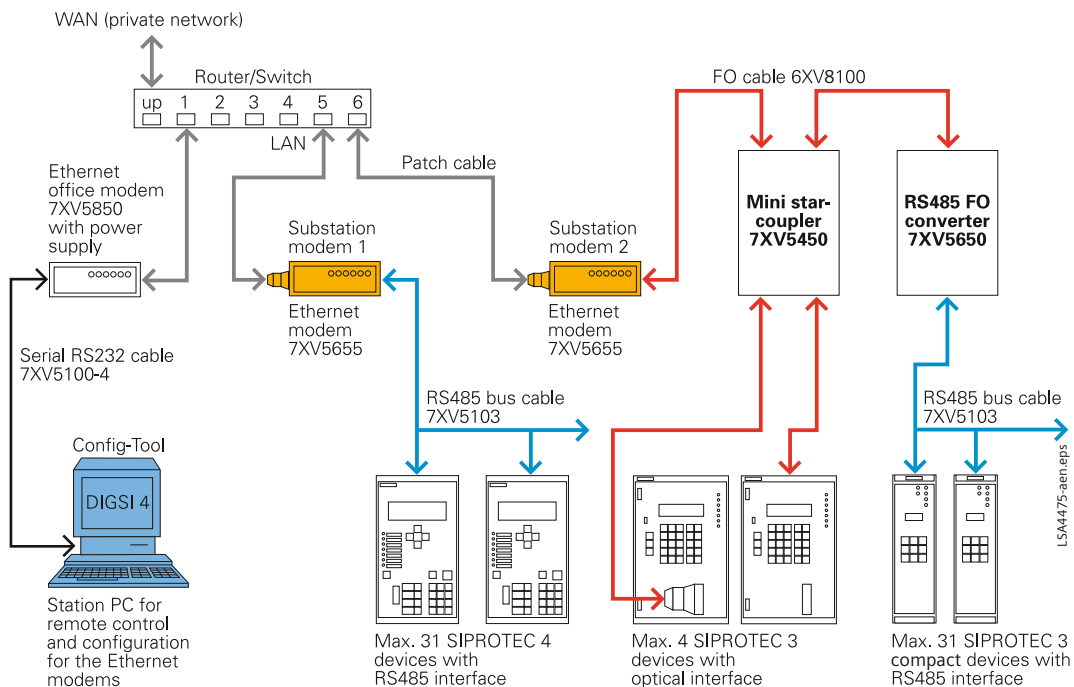

Fig. 13/37
Operation of various SIPROTEC protection unit generations via Ethernet modems

Using the office computer and DIGSI 4, both substations 1 and 2 may be dialed up via the Ethernet modems. An IP point-to-point data connection is established between the office and corresponding substation modem when dialed up via the network. This is maintained until the office modem terminates the connection. The serial data exchange takes place via this data connection whereby the modem converts the data from serial to Ethernet with full duplex mode. Between the office modem and the office PC the highest data rate e.g. 57.6 kbit/s for SIPROTEC 4 devices is always used. The serial data rate of the substation modem is adapted to the data rate required by the protection relays e.g. substation modem 1 with 57.6 kbit/s for SIPROTEC 4 and substation modem 2 with 9.6 kbit/s for SIPROTEC 3 devices. These settings are only pre-set once in the modem.

The Ethernet modems are integrated similarly to telephone modems in DIGSI 4. Instead of the telephone number, the pre-set IP address assigned to the modem is selected. If later an Ethernet connection is available in the substation, the existing modem can be replaced by an Ethernet modem. The entire serial bus structure and cabling may remain unchanged.

Technical data

Connections

RS232 interface 9-pin SUB-D or
 RS485 interface 9-pin SUB-D settable by switches
 FO interface 820 nm with ST connectors for the connection to 62.5/125 µm multi-mode FO cables.
 Ethernet 10BaseT, 10/100 Mbit, RJ45 connector
 Power supply / Fail safe relay with screw-type terminals

Housing

Rail mounting, plastic, charcoal grey, 90 x 90 x 107 (W x H x D) in mm

Wide-range power supply / fail safe relay

Auxiliary voltage 24 to 250 V DC and 115/230 V AC connected with screw-type terminals
 Fail safe relay for power supervision connected with screw-type terminals

Indication (8 x LED)

Power	Operating voltage o.k.	System	RS232 connection established
RS232 T x D	Transmitting data to RS232	RS232 R x D	Receiving data from RS232
LAN T x	Transmitting data to LAN	LAN R x	Receiving data from LAN
Error	Error on RS232	Link LAN	LAN connection established

Selection and ordering data

Description	Order No.
<i>Ethernet modem</i>	<i>7XV5655 - 0BB00</i>

Ethernet modem for serial, asynchronous transmission of data up to 57.6 kbit/s via the 10/100 Mbit Ethernet and configuration software
 DIN-rail device mounting device suitable for substation.
 Connection to Ethernet via RJ45 connector. Serial connection SUB-D 9-pin socket
 RS232/RS485 interface settable by switches.
 FO interface 820 nm for 62.5/125 µm multi-mode - FO cables.
 Auxiliary supply 24 - 250 V DC and 115/230 V AC.
 Fail safe contact for device supervision.
 With gender-changer (pin-pin) for adaptation to
 DIGSI - cable 7XV5100-4 (cable not included in the scope of supply).

7XV5655-0BA00 Ethernet Serial Hub for Substations



Fig. 13/38
Front view of Ethernet serial hub for substation

Description

By means of the serial hub and the associated configuration software it is possible to establish serial communication via an Ethernet network between a PC or notebook running DIGSI 4 and SIPROTEC protection relays. The configuration software installs virtual serial interfaces (Com ports) on the PC. Each COM port is allocated to a serial hub within the network by means of its IP address. This must be set in the serial hub. The PC is connected to the network via Ethernet interface. The protection relays are connected via an RS232/RS485 or FO interface to the serial hub. Connection with DIGSI is achieved via the virtual COM port on the PC and the IP address of the serial hub in the substation. The serial data is packed as user data into a secure IP protocol in the PC and transferred via the Ethernet connection to the serial hub. The requirements regarding standard compliant gap-free transmission of serial DIGSI or IEC 60870-5-103/101 telegrams (frames) via the network is complied with by the communication driver on the PC and the serial hub which monitor the serial telegram communication. The serial IEC telegrams are transferred in blocks across the Ethernet. Data communication is full duplex. Control signals of the serial interfaces are not used.

Function overview

- Configuration software for Windows NT/2000/XP to configure virtual COM ports on the PC and for configuration of the serial hub.
- RS232/RS485 - interfaces for data transfer and configuration of the serial hub
- FO interface for serial data transfer
- Serial data rate and data format (RS232) for the terminal devices is selectable from 2.4 kbit/s up to 57.6 kbit/s with data format 8N1, 8E1.
- 10 Mbit Ethernet interface (LAN) to the 10/100 Mbit Ethernet network.
- Better security with password protection for the access to the protection relays via the serial hub
- Exchange of serial data via Ethernet network (e.g. DIGSI protocol, IEC 60870-5-103 protocol)
- Exchange of serial protocols via Ethernet without gaps in the telegram structure

Application

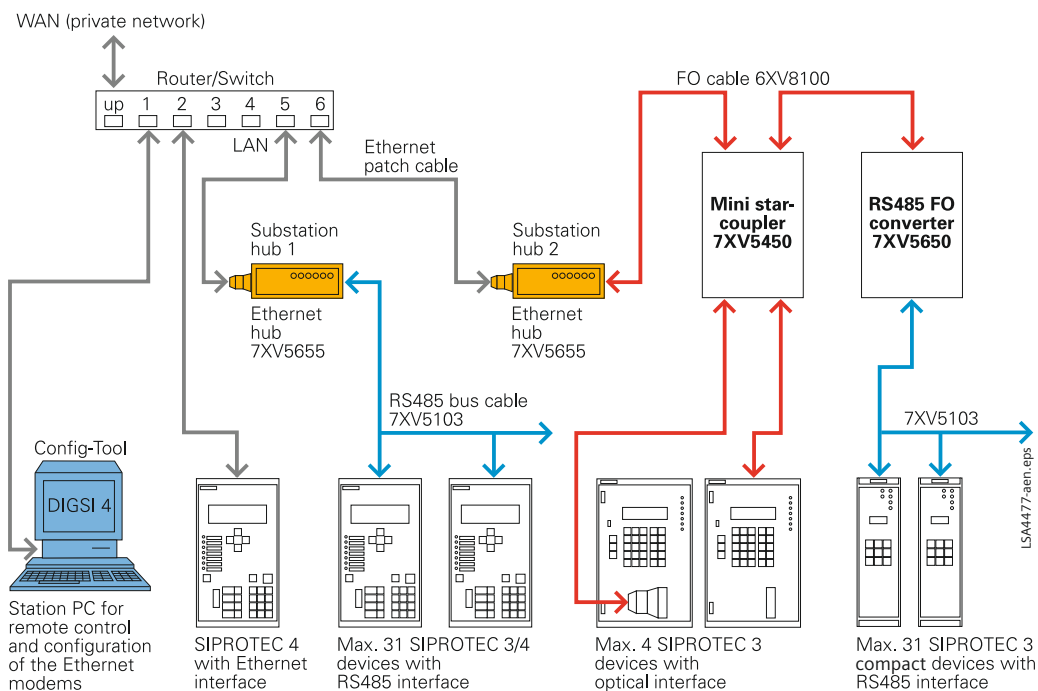

Fig. 13/39
Operation of various SIPROTEC protection unit generations via serial hub

From the office PC running DIGSI 4 it is possible to select one of the serial hubs 1 and 2 via one of the virtual COM ports. In DIGSI 4, when the COM port is selected, a IP point-to-point data connection via the network is established and maintained between the office and the relevant substation modem until the interface is released. The serial data exchange takes place via this data link, whereby the data conversion from serial to Ethernet is full duplex. The office PC towards the network is always operating with high data rate, as the data is fed to the network via the network driver on the PC. The serial data rate of the serial hub in the substation is adapted to the baud rate set in the protection relay, e.g. serial hub 1 with 57.6 kbit/s for SIPROTEC 4 and serial hub 2 with 9.6 kbit/s for SIPROTEC 3 devices. These parameters must be pre-set on the serial hub. With DIGSI 4 the serial hubs are integrated by means of further serial COM ports (max. 254). The connection to the IP address of the serial hub in the network is achieved by opening the corresponding COM port. If an Ethernet network to the substation or in the substation is available, serial data can then be transferred via this network.

The existing serial star or bus structure with cabling in the substation can still be used.

SIPROTEC 4 devices from version 4.6 and newer with integrated Ethernet interface may be connected directly to the router or switch by means of a patch cable.

Technical data

Connections

RS232 interface 9-pin SUB-D socket or
 RS485 interface 9-pin SUB-D socket selectable via DIL switch.
 FO interface 820 nm with ST connectors for connection to multi-mode FO cables.
 Ethernet 10BaseT, 10/100 Mbit, RJ45 connector to Ethernet
 Auxiliary voltage/alarm relay (5 terminals)

Housing

Rail mounting, plastic, charcoal grey, 90 x 90 x 107 (W x H x D) in mm

Wide-range power supply

Auxiliary voltage 24 to 250 V DC and 115/230 V AC connected with screw-type terminals
 Alarm relay for monitoring of the device

Indication (8 x LED)

Power	Operating voltage o.k.	System	RS232 connection established
RS232 T x D	Transmitting data to RS232	RS232 R x D	Receiving data from RS232
LAN T x	Transmitting data to LAN	LAN R x	Receiving data from LAN
Error	Error on RS232	Link LAN	LAN connection established

Selection and ordering data

Description

Order No.

*Ethernet hub for substations**7XV5655-0BA00*

Serial hub for serial, asynchronous transfer of data up to 57.6 kbit/s
 via 10/100 Mbit Ethernet including configuration software.
 Connection to the Ethernet via RJ45 connector. Serial connection with
 RS232/RS485 interface via SUB-D 9-pin socket or optical with 820 nm
 ST connector and multi-mode FO cable.
 Wide-range auxiliary supply for 24 - 250 V DC and 115/230 V AC.
 With gender-changer (pin-pin) for adaptation to
 DIGSI cable 7XV5100-4 (cable not included in the scope of supply).

7XV5662-0AA00 / 7XV5662-0AA01 Communication Converter for X.21/RS422 and G.703.1



Fig. 13/40
Communication converter for X.21/RS422 and G.703.1

Description

The communication converter for coupling to a communication network is a peripheral device linked to the protection device via fiber-optic cables, which enables serial data exchange between two protection relays. A digital communication network is used. The electrical interfaces in the CC-XG for the access to the communication device are selectable as X.21 (64 kbit/s, 128 kbit/s, 256 kbit/s or 512 kbit/s) or G.703.1 (64 kbit/s). At the opposite side, the data are converted by second communication converter so that they can be read by the second device. The communication converters thus allow two protection devices to communicate synchronously and to exchange large data volumes over large distances. Typical applications are the serial protection interfaces of differential protection and distance protection of the devices 7SD5, 7SD6, 7SA52 and 7SA6, where 7XV5662-0AA00 must be used.

Should asynchronous serial data of differential protection 7SD51 or of the binary signal transducer 7XV5653 be transmitted, the device 7XV5662-0AA01 must be used (asynchronous from 300 bit/s to 115.2 kbit/s dependent on the baudrate set for X.21 or G.703.1 interface). Interference-free connection to the protection device is achieved by means of a multi-mode fiber-optic cable, with ST connectors at the CC-XG. The maximum optical transmission distance is 1.5 km (0.93 mile).

The data transfer between the protection devices is realized as a point-to-point connection that is bit-transparent. Data must be exchanged via dedicated communication channels, not via switching points.

Function overview

- Optical interface with ST connector for connection to the protection unit
- Distance: 1.5 km with 62.5/125 μm multi-mode FO cable between CC-XG and the protection unit / serial device
- Electrical interface to the communication device via SUB-D connector (X.21, 15 pins, settable to 64, 128, 256 or 512 kbit/s) or with 5-pin screw-type terminals (G.703.1, 64 kbit/s).
- Synchronous data exchange for 7SD52, 7SD6, 7SA6 and 7SA52 protection relays (communications converter version – 0AA00)
- Asynchronous data exchange for 7SD51 protection relay, 7XV5653 or other devices with asynchronous interface (communication converter version – 0AA01)
- Max. cable length between communication device and communication converter: 100 m for X.21 /RS422
- Max. cable length between communication device and communication converter: 300 m for G.703.1
- Monitoring of:
 - auxiliary supply voltage,
 - clock signal of communication network
 - and internal logic
- Loop test function selectable by jumpers in the CC-XG
- Wide-range power supply unit (PSU) for 24 to 250 V DC and 115 to 250 V AC

Application

The CC-XG can be used for two applications. One application is the synchronous serial data exchange (converter version – 0AA00) between SIPROTEC 4 differential relays (7SD52, 7SD6) and/or the serial teleprotection between distance relays (7SA6 and 7SA52). The relays have to be equipped with an optical 820 nm plug-in module “FO5”.

Another application is the transmission of asynchronous serial data to the line differential protection relay 7SD51 or the binary signal transmitter 7XV5653.

Functions

The protection unit is optically linked to the CC-XG, which makes interference-free data transfer between the CC-XG and the protection unit possible. The communication converter is located close to the communication device. It adapts the FO active interface of the protection relay to the electrical specifications of the communication network interface. The interface types – optionally X.21/RS422 or G.703.1 – and the required transmission rate can be set by means of jumpers.

Data transfer between the protection units is effected on the basis of a point-to-point connection, furthermore it is a synchronous, bit-transparent transmission via the communication network.

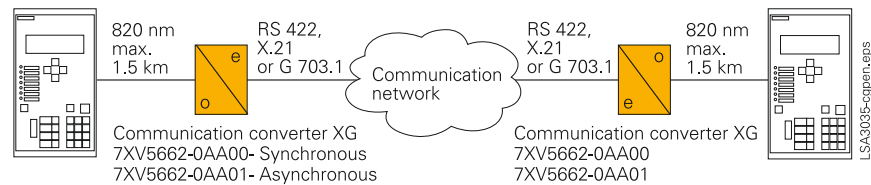

Fig. 13/41 Connection of two protection devices via a communication network linked with 7XV5662-0AA0x

Technical data

Rated auxiliary voltage

24 to 250 V DC	± 20 %
115/230 V AC	± 20 % without switchover
Power consumption	Approx. 3.5 W

LEDs

4 LEDs	
LED 1	Red: Error
LED 2	Yellow: Receiving from X.21/RS422/G.703 interface
LED 3	Yellow: Transmitting to X.21/RS422/G.703 interface
LED 5	Green: Operating voltage o.k.

Connectors

Power supply	2-pole screw-type terminal
Alarm/ready contact	3-pole make/break contact
Serial G.703.1 interface	5-pole receive and transmit line
SUB-D connector	15-pin SUB-D connector for electrical X.21/RS422 interface
FO cable	820 nm, 2 ST connectors for TxD and RxD for 62.5/125 μm multi-mode FO (max. distance to protection unit 1.5 km)

Housing

Aluminium die-cast housing	Dimensions 188 x 56 x 120 mm (WxHxD)
Weight	Approx. 0.8 kg
Degree of protection	According to EN 60529: IP41
For snap-on mounting onto 35 mm	EN 50022 rail

Technical data

Operating mode

Synchronous operation with	7XV5662-0AA00 for 7SD52, 7SD6, 7SA52 and 7SA6	
	<i>G.703.1: Interface selectable by jumper X30 in position 2 - 3</i>	
	Setting in the protection unit	Setting in CC-XG by jumper
	64 kbit/s per parameter	64 kbit/s by jumper X20 = 1
	<i>X.21/RS422: Interface selectable by jumper X30 in position 1 - 2</i>	
	Setting in the protection unit	Setting in CC-XG by jumper:
	64 kbit/s per parameter	64 kbit/s by jumper X20 = 1
	128 kbit/s per parameter	128 kbit/s by jumper X22 = 1
	256 kbit/s per parameter	256 kbit/s by jumper X24 = 1
	512 kbit/s per parameter	256 kbit/s by jumper X26 = 1
Asynchronous operation with	7XV5662-0AA01 for 7SD51, 7XV5653 and units with asynchronous serial interface (no handshake supported, only serial TxD and RxD signals are supported)	
	<i>G.703.1: Interface selectable by jumper X30 in position 2 - 3</i>	
	Setting in protection unit	Setting in CC-XG by jumper
	max. 19.2 kbit/s	64 kbit/s by jumper X20 = 1
	<i>X.21/RS422: Interface settable by jumper X30 in position 1 - 2</i>	
	Setting in protection unit	Setting in CC-XG by jumper
	max. 19.2 kbit/s async.	64 kbit/s by jumper X20 = 1
	max. 38.4 kbit/s async.	128 kbit/s by jumper X22 = 1
	max. 57.6 kbit/s async.	256 kbit/s by jumper X24 = 1
	max. 115.2 kbit/s async.	512 kbit/s by jumper X26 = 1

Selection and ordering data

Description	Order No.
<u>Communication converter for X.21/RS422/G.703.1 interface</u>	<u>7XV5662 - 0AA0</u> <input type="checkbox"/>
Converter to synchronous or asynchronous serial coupling of protection units with optical inputs/outputs with ST connector to communication devices with electrical X.21/RS422 or G.703.1 interface. Connection to protection unit via FO cable for 62.5/125 µm and 820 nm wavelength, max. distance 1.5 km, ST connectors Electrical with X.21/RS422 (15-pin SUB-D connector) or G.703.1 (screw-type terminal) Baud rate and interface type selectable by jumpers	
For synchronous operation with 7SD52, 7SD6, 7SA6, 7SA52	0
For asynchronous operation with 7SD51, 7XV5653 or serial devices	1

7XV5662-0AC00/7XV5662-0AC01 Communication Converter for Pilot Wires



Fig. 13/42
Communication converter for pilot wires

Description

The communication converter copper (CC-CO) is a peripheral device linked to the protection device which enables serial data exchange between two protection relays. It uses a single pair of copper wires (pilot wire) that may be part of a telecommunications cable or of any other suitable symmetrical communications cable (no Pupin cable). At the opposite side, the data are converted by a second communication converter so that they can be read by the second protection device. The communication converters (master/slave) thus allow two protection devices to communicate synchronously and to exchange large data volumes over considerable distances. Typical applications are the protection interfaces of differential protection and distance protection of the devices 7SD5, 7SD6, 7SA52 and 7SA6, where 7XV5662-0AC00 must be used (synchronous connection with 128 kbit/s). Should asynchronous serial data of differential protection 7SD5 or of the binary signal transducer 7XV5653 be transmitted, the device 7XV5662-0AC01 must be used (asynchronous from 300 bit/s to 38.2 kbit/s).

Interference-free connection to the protection device is achieved by means of a multi-mode fiber-optic cable, with ST connectors at the CC-CO. The maximum optical transmission distance is 1.5 km (0.93 mile). The data transfer between the protection devices is realized as a point-to-point connection that is bit-transparent. Data must be exchanged via dedicated pilot wires, not via switching points.

Function overview

- Optical interface with ST connector for connection to the protection unit
- Distance: 1.5 km with 62.5/125 μm multi-mode FO cable between CC-CO and the protection unit
- Electrical interface to the pilot wire (line) with 2 screw-type terminals. 5 kV isolated
- Synchronous data exchange for 7SD52, 7SD6, 7SA6 and 7SA52 via pilot wire (typ. 15 km) (CC-CO version -0AA00)
- Asynchronous data exchange for 7SD51, 7XV5653 or other units with asynchronous interface (CC-CO version -0AA01) (typ. 15 km)
- Loop test function selectable by jumpers in CC-CO
- Master or slave mode of the CC-CO selectable by jumper (one master and one slave device required at the end of the pilot wire, factory presetting: master mode)
- Wide-range power supply with self-supervision function and alarm contact

Application

The CC - CO can be used for two applications. One application is the synchronous serial data exchange (converter version – 0AA00) between SIPROTEC 4 differential relays (7SD52, 7SD6) and/or the serial teleprotection between distance relays (7SA6 and 7SA52). The relays have to be equipped with an optical 820 nm plug-in module “FO5”.

Another application is the transmission of asynchronous serial data via pilot wires to the line differential protection relay 7SD51 or the binary signal transmitter 7XV5653. Other serial devices may also be used.

If the maximum distance between the protection units is longer than spanned by two CC-CO, the converters can be cascaded (see Fig. 13/44). A power supply between the two master units is required. If the isolation level is higher than 5 kV (provided by the pilot wire inputs of the units), external isolation transformers (barrier transformers) can be used on both sides. These transformers offer 20 kV isolation voltage and thus help to avoid hazardous high voltages at the inputs of the CC-CO, which might be induced by a short-circuit from a parallel power line or cable.

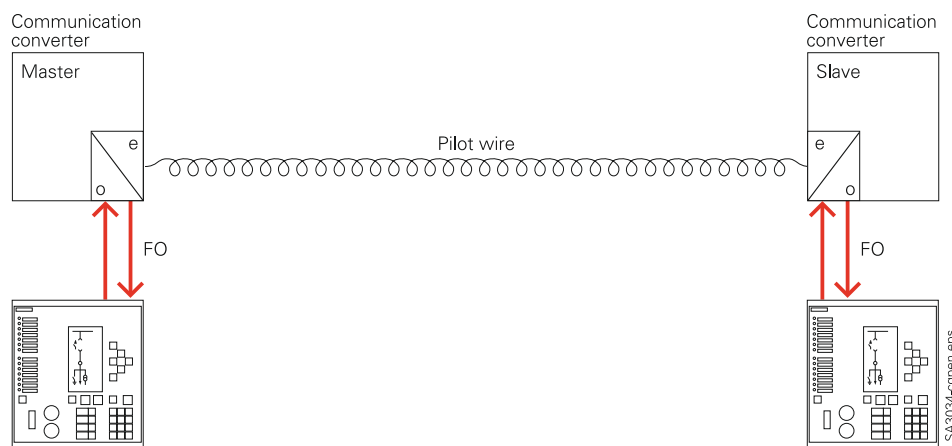

Fig. 13/43

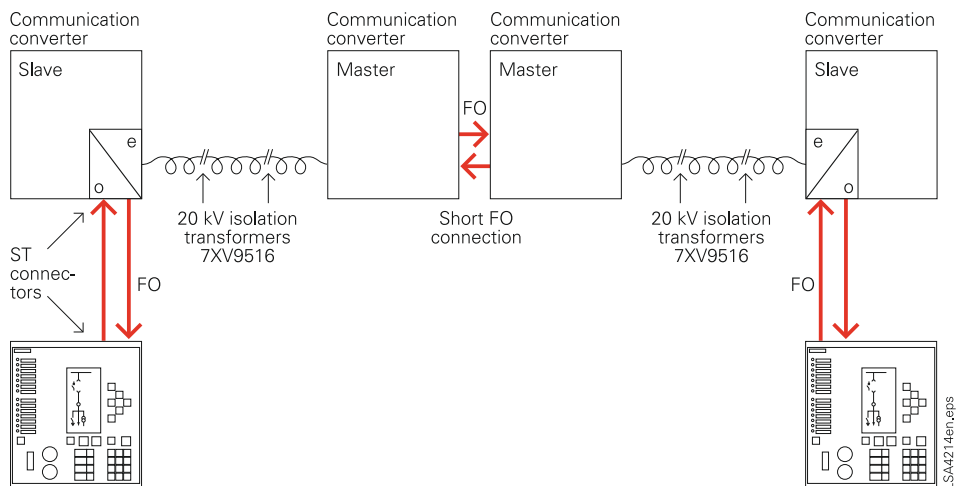

Fig. 13/44

Functions

The protection unit is optically linked to the CC-CO, which makes interference-free data transfer between the CC-CO and the protection unit possible. The communication converter is located close to the pilot wire. It converts serial data of the protection unit into a frequency-modulated signal. This signal is transmitted via one pair of copper wires of a pilot wire/communication line (bi-directional, full duplex operation).

By means of jumpers, one unit is defined as “master” and the other unit as “slave”. In a “training” during commissioning, the electrical characteristics of the pilot wire are measured by pressing a pushbutton, and the CC-COs are tuned to these characteristics.

The measured characteristics are used as parameters that will be adhered to for optimal data transfer. Digital data transfer makes a low insulation level of the pilot wire possible, because no high voltages are produced on the pilot wire during short-circuit conditions.

Data transfer between the protection units is effected on the basis of a point-to-point connection, furthermore it is a synchronous, bit-transparent transmission. Due to the telegram-backed data exchange, mal-operation is ruled out.

Technical data

Rated auxiliary voltage	
24 to 250 V DC	± 20 %
115/230 V AC	± 20 % without switchover
LEDs	
4 LEDs	
LED 1	Red: Line activation
LED 2	Yellow: Line transparent
LED 3	Yellow: Data transfer
LED 5	Green: Power ON
Connectors	
Power supply	2-pole screw-type terminal
Alarm/ready contact	3-pole make/break contact
Pilot wire	2-pole for pilot-wire connection 5-kV isolated inputs
FO cable	820 nm, 2 ST connectors for TxD and RxD for 62.5/125 µm multi-mode FO (max. distance to protection unit 1.5 km)
Pushbutton	
Measuring and training of parameters of the pilot wire	
Housing	
Aluminum die-cast housing	Dimensions 188 x 56 x 120 mm (WxHxD)
Weight	Approx. 0.8 kg
Degree of protection	According to EN 60529: IP41
For snap-on mounting onto 35 mm	EN 50022 rail
Operating mode	
Synchronous operation with	7XV5662-0AC00 for 7SD52, 7SD6, 7SA52 and 7SA6 Setting in the protection unit: 128 kbit/s per parameter Setting in CC - CO: 128 kbit/s. No setting required
Asynchronous operation with	7XV5662-0AC01 for 7SD51, 7XV5653 and units with asynchronous serial interface (no handshake supported, only serial TxD and RxD signals are supported) Max. baud rate for protection unit: 38.4 kbit/s Max. baud rate for CC - CO 128 kbit/s. No setting required
Max. distance with pilot wire	AWG 22 / 0.33 mm ² / 51.7 Ω/km: max. 11 km AWG 26 / 0.13 mm ² / 137 Ω/km: max. 4.5 km Shielded twisted pair (STP) recommended. Max. loop resistance: 1400 Ω Attenuation < 40 dB at 80 kHz

Selection and ordering data

Description	Order No.
Communication converter for pilot wires	7XV5662-0AC0 <input type="checkbox"/>
Converter for synchronous or asynchronous serial coupling of protection units with optical inputs/outputs with ST connector to conventional pilot wires. 5-kV isolation of unit analog inputs towards the pilot wires. Connection to protection unit via FO cable for 62.5/125 µm and 820 nm wavelength, max. distance 1.5 km, ST connectors Synchronous serial data 128 kbit/s Asynchronous serial data rate max. 57.2 kbit/s	
For synchronous operation with 7SD52, 7SD6, 7SA6, 7SA52	0
For asynchronous operation with 7SD51, 7XV5653 for other units	1

7XV5662-0AD00 Two-Channel Serial Communication Converter G.703.6



Fig. 13/45
Communication converter

Function overview

- Interference-free protection data transfer of two independent serial data signals, selectable either in synchronous or asynchronous mode.
- PC interface for operation of devices at the remote line end.
- Network interface as E1 or T1 format for connection to multiplexer.
- Wide range power supply from 24 V to 250 V DC and 115/230 V AC with failsafe relay.
- Indication of the data exchange via LED
- Integrated commissioning aid (loop test)

Description

The CC-2M communication converter is used for serial data transmission over long distances via a communication network. It converts synchronous or asynchronous serial 820 nm optical input signals at inputs FO1 and FO2 to a network interface and again returns these signals at the remote terminal via the latter's interfaces. FO1 and FO2 may be configured independently for either synchronous or asynchronous operation, but must be set to the same operating mode at both ends. In synchronous mode, the interface should only be used for exchanging the protection data of the 7SD5/7SD6 differential protection or 7SA52/7SA6 distance protection and is preconfigured for 512 kbit/s. In asynchronous mode, the interface can be used for connection of devices with baud rates between 1.2 to 115.2 kbit/s. A further asynchronous electrical RS232 interface is provided for max. 115.2 kbit/s. It provides for the connection of a serial PC interface with DIGSI and thereby the operations interface to SIPROTEC devices at the remote end. The G.703.6 network interface is provided in the form of 4-way screw terminals and can be configured as a 2-Mbit/s interface with European E1 format or as a 1.544-Mbit/s interface in the American T1 format. All settings of the device are made with jumpers, so that no special PC software is required.

Application

Two protection devices e.g. 7SD52/7SD610 differential protection or 7SA52/7SA6 distance protection, exchange protection data via FO1. Interference-free data exchange is performed via the communication network, the devices being connected synchronously with 512 kbit/s (connection 1; see Fig. 13/46). Protection remote control with DIGSI is connected to FO2 of the converter via a 7XV5450 mini star-coupler. This port provides the serial connection to the other substation with a PC on which DIGSI is installed. In this way, the remote protection devices can be remotely interrogated via FO2 (connection 2). The baud rate is optimally set to 57.6 kbit/s for SIPROTEC 4 devices, so that there is no difference from local operation. The data of the devices on the other substation can be changed and read out during commissioning and operation. Alternatively, it is possible to connect a substation control system or additional protection data transmission to FO2. This makes for optimum use of the 1.544/2 Mbit/s transmission channel for two separate serial connections. In addition, an asynchronous serial connection is available via the RS232 interface, which can be used to temporarily operate devices of the other substation with DIGSI.

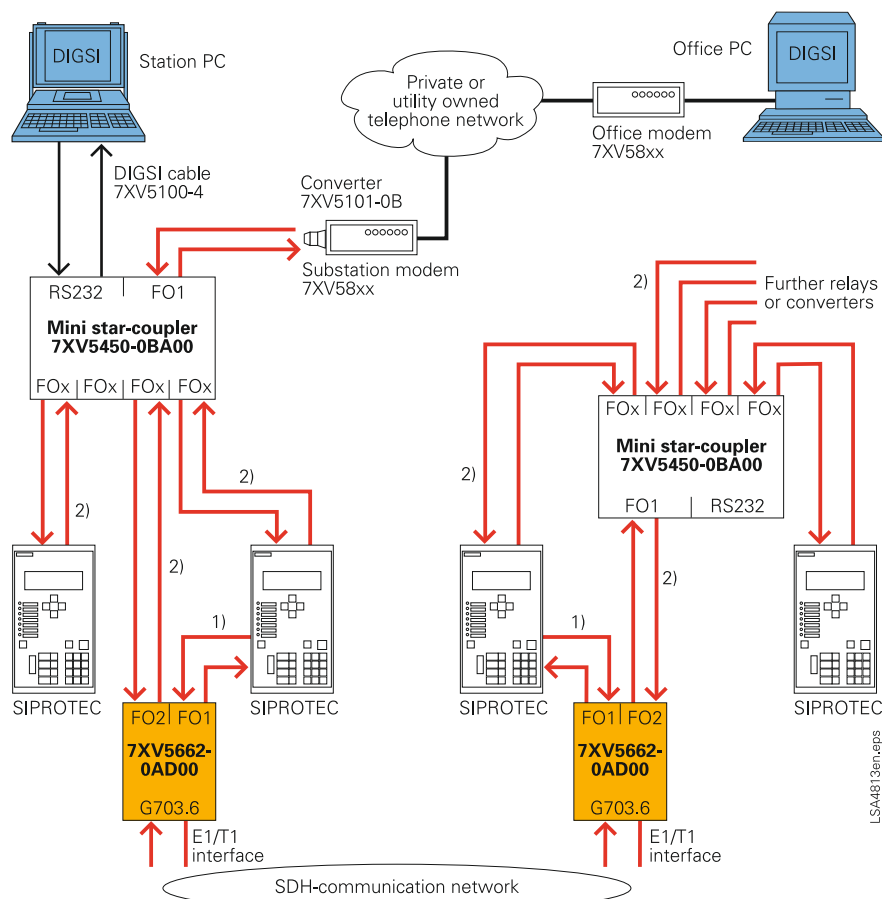

- 1) Protection data transmission with 512 kbit/s (synchronous)
2) Remote control with DIGSI (asynchronous)

Fig. 13/46

Protection data transmission and remote control of a substation via a communication network

Technical data

Connections

FO 1 / 2	ST plug/ 820 nm for 50/125 μm or 62.5/125 μm multi-mode FO cable (max. 1.5 km)
RS232	For asynchronous connection from 1.2 – 115.21 kbit/s
Power supply	2-pole screw-type terminal
Fail safe relay	3-pole screw-type terminal with NC/NO contact
Network E1/T1	4-pole screw-type terminal

Housing

Aluminium housing 188 x 56 x 120 mm for mounting on 35 mm rail mounting according to EN 50032 weight 0.8 kg. Protection class according to EN 60529: IP41

Power supply

Wide range 24 to 250 V DC and 115/230 V AC, 50/60 Hz

Displays

4 LEDs	
Green	Power supply
Red	Fault alarm
2 yellow	Data transfer

Selection and ordering data

Description	Order No.
<p><u>Two-channel serial 1.544/2 Mbit/s communication converter</u></p> <p>Conversion of 2 independent serial FO interfaces with synchronous or asynchronous data to a E1 network interface with 2 Mbit/s (G.703.6) or T1 network interface (1.544 Mbit/s). Two independent serial optical input channels with ST connectors and 820 nm for multi-mode FO cable for a max. of 512 kbit/s/115.2 kbit/s for synchronous/asynchronous data. An electrical serial RS232 interface with a max. 115.2 kbit/s constructed as a 9-pin SUB-D socket for connection with DIGSI 7XV5104 cable. Connection from multiplexer to the E1/T1 network interface via a 4-pole screw-type terminal. Wide-range power supply of 24 V to 250 V DC and 115/230 V AC. A make/break fail safe contact for power supply faults or interruption of the data connection. All settings are made with jumpers in the device (presetting for E1 and synchronous serial data input).</p>	<p>7XV5662-0A□00</p> <p style="text-align: right;">D</p>

7XV5662-6AD10 Resistance Temperature Detector (RTD-Box) TR1200



Fig. 13/47a
7XV5662-6AD10 RTD-box TR1200

Function overview

- 3-digit temperature display
- 12 inputs for temperature sensors, 1 to 12 sensors can be connected
- Pt 100 thermostats with 2- or 3-conductor technology
- 1 error relay (potential-free change-over contact)
- RS485 interface (ZIEHL standard protocol and MODBUS RTU protocol)
- LED signal the measuring channel, error state, relay function and RS485 activity
- Code lock prevents parameter manipulation
- TR600 compatible (to replace one TR600 with 6 sensors connected)
- Universal power-supply 24 to 240 V AC/DC
- Snap-on mounting onto 35 mm standard rail EN 60715

Description

The RTD-box TR1200 can capture up to 12 temperatures with 12 measuring inputs. 2- and 3-conductor Pt 100 sensors are supported. For the 2-conductor mode, the measured conductor resistance can be compensated for with a corresponding setting. The measurement of temperatures may be simulated for commissioning purposes.

The output of measured values to the protection device is compatible with TR600 and implemented with bus cable 7XV5103-7AAxx via a RS485 bus.

All settings are done via 3 push buttons on the front of the device. Entry can be blocked via a code.

The TR1200 has a wide-range power supply from 24 – 250 V DC and 115 / 230 V AC as well as an alarm relay. Sensor failure or sensor short-circuit are alarmed and transmitted via protocol to the SIPROTEC device.

Application

Communication via RS485 bus

The RTD-box TR1200 is connected via a RS485 interface to one SIPROTEC 4 bay device with thermo function (e. g. 7SJ6, 7UT6, 7UM6) or to the compact protection 7SK80 via a serial RS485-interface (Port B).

The special cable 7XV5103-7AAxx is used for the connection. In the event of remote measuring locations, the connections may also be done using multi-mode fiber-optic conductors and the converter 7XV5650 (see Fig. 13/47b).

For detailed information please visit www.siemens.com/siprotec

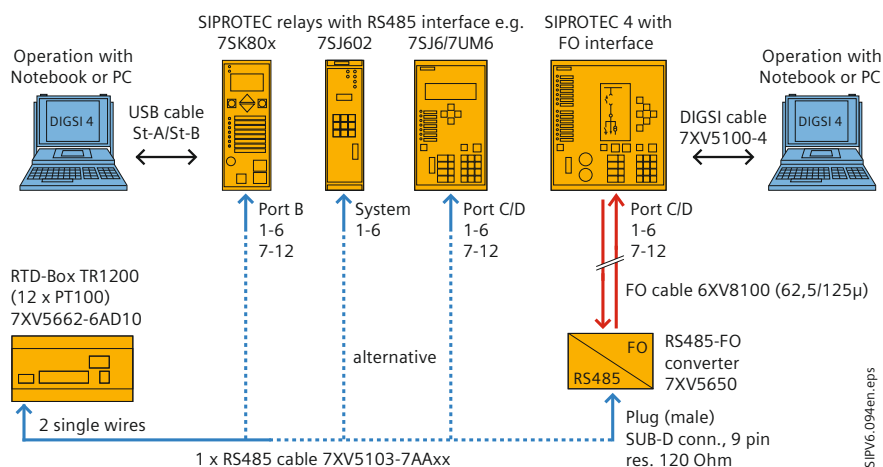

Fig. 13/47b
Connection of devices via a serial RS485 bus or FO cable

Technical data

Rated auxiliary voltage	
Auxiliary voltage V_S	24 – 240 V AC/DC, 0/45 – 65 Hz < 5 VA
Tolerance	20.4 – 297 V DC, 20 – 264 V AC
Relay output	
Number	1 changeover contact (CO)
Switching voltage	Max. 415 V AC
Switching current	Max. 5 A
Switching power	Max. 2000 VA (ohmic load) Max. 120 W at 24 V DC
De-rating factor with $\cos \varphi = 0.7$	0.5
U_L electrical ratings:	250 V AC, 3 A general use D300 1 A 240 V AC
Rated operating current I_E	AC 15 $I_E = 2$ A $V_E = 250$ V DC 13 $I_E = 2$ A $V_E = 24$ V $I_E = 0.2$ A $V_E = 125$ V $I_E = 0.1$ A $V_E = 250$ V
Recommended fuse	T 3.5 A (gL)
Contact service life, mech.	1×10^7 switching operations
Contact service life, electr.	1×10^5 switching operations at 250 V AC / 5 A
Sensor connection	
Number	12 x Pt 100 according to EN 60751
Measuring cycle/measuring time	0.25 to 3 s (depending on the number of sensors)
Measuring cycle/circuit resistance	0.25 to 30 s (per measuring cycle of sensor)
Measuring range	-199 to 850 °C
Resolution	1 °C
Accuracy	± 0.5 % of measured value ± 1 K
Sensor current	≤ 0.8 mA
Temperature drift	< 0.04 °C / K
Short circuit	< 15 Ohm
Interruption	> 400
Sensor resistance + circuit resistance	Max. 500 Ohm
RS485 interface	
Device address	0 to 96
Baud rate	4800, 9600, 19200 bit/s
Parity	N, O, E (no, odd, even)
Max. cable length	1000 m at 19200 bit/s
Serial protocol	Serial RTD – Protocol Ziehl / SIPROTEC See manual for detailed protocol description

Technical data

Test conditions	
Acc. to	EN 61010
Rated impulse voltage insulation	4000 V
Overvoltage category	III
Pollution rate	2
Rated insulation level V_i	300 V
Duty cycle	100 %
Perm. ambient temperature	- 20 °C to + 65 °C EN 60068-2-2 dry heat
Electrical isolation	Power supply – measuring inputs 3820 V DC
No electrical isolation	RS 485 interface – measuring inputs
EMC-tests	EN 61326-1
EMC test for noise emission	EN 61000-4-3
Fast transient disturbances/Burst	EN 61000-4-4 ± 4 kV Pulse 5/50 ns, $f = 5$ kHz, $t = 15$ ms, $T = 300$ ms
High-energy surge voltages (SURGE)	IEC 61000-4-5 ± 1 impulse: 1.2 / 50 μ s (8/20 μ s)
Electrostatic discharge	IEC 61000-4-2 ± 4 contact discharge, ± 8 kV air discharge
Housing	
Housing type	V8, distribution panel mounting
Size (W x H x D)	140 x 90 x 58 mm
Depth/Width	55 mm/8 TE
Circuit termination single strand	Per 1 x 1.5 mm ²
Braided conductor with crimp lug	Per 1 x 1.0 mm ²
Tightening torque of terminal screw	0.5 Nm (3.6 lb.in)
Protection class of housing/terminals	IP30 / IP20
Mounting vertical/horizontal	Optional
Affixing	Snap-on mounting onto standard rail mounting 35 mm acc. to EN 60715 or screw mounting (with 2 additional brackets)
Weight	Approx. 370 g

Selection and ordering data

Description	Order No.
<i>Resistance temperature detector (RTD-box) TR1200</i>	<i>7XV5662-6AD10</i>
Distributed input-box for 12 RTD-connections Pt100 Rail mounting plastic Protection class IP21 1 serial interface RS485 for communication with SIPROTEC devices for measurements and fault reports. Wide-range power supply 24 to 240 V AC/DC Note: The device can be operated in a 7XV5662-2AD10 or 7XV5662-5AD10 compatible mode.	

7XV5662-7AD10 Universal Relay/RTD-/20 mA-Box TR800 Web



Fig. 13/48a
7XV5662-7AD10 Universal relay / RTD-box TR800

Description

The universal relay TR800 Web has 8 measuring/sensor inputs and is able to capture 8 temperatures via PT100- (Ni100 and Ni120) elements. The measuring values 1 - 6 may be transmitted to SIPROTEC 4 devices with thermo function via protocol. Two universal relays with a total of 12 measuring inputs can be connected.

Connection is established via a serial RS485 interface (see Fig. 13/48d). The TR800 is protocol compatible with the TR600 (7XV5662-3AD10, 7XV5662-5AD10) on the serial RS485 interface, and transmits the 6 temperatures in the same format. In this mode, the TR800 can replace the TR600.

In the case of 7SK80 motor protection, the connection may alternatively be made via the Ethernet interface, if the system interface is (pre-)assigned (see Fig. 13/48b + 13/48c). The universal relay is operated and configured via the Ethernet interface with a Web browser. Three conductor thermo elements are supported. For the dual conductor connection the measured line resistance can be compensated for by a software setting. Furthermore, temperatures can be simulated to test the thermo function in the SIPROTEC devices.

Alternatively to thermo sensors, 8 analog values 0/4 – 20 mA DC and 0 – 10 V DC may be measured. The output can be scaled and the designation (°C, V, A, %) can be adapted in the TR800. The transmission to the SIPROTEC – device however takes place via the RTD – protocol in temperature format. 6 of the 8 analog sensor values are available there. With 2 TR800 12 values are available. For example 5.5 mA is transferred with a temperature value of 55 in this way and may either be displayed as temperature in the SIPROTEC device or compared with a set limit via a threshold value. This allows for the processing of analog dimensions in SIPROTEC devices with thermo function or their transmission to a substation control unit (e.g. SICAM PAS). In the bay control unit 6MD66 V4.8 (available since 05/2009) all 8 measuring inputs are available.

The TR800 has a wide-range power supply from 24 V – 250 V DC and 115/230 V AC as well as an alarm relay. Sensor failure or sensor short-circuit are alarmed and transmitted via protocol to the SIPROTEC device.

Function overview

- 8 measuring inputs:
 - Pt 100, Pt 1000 in 2- or 3-conductor technology
 - KTY 83 or KTY 84
 - Thermocouples type B, E, J, K, L, N, R, S, T
 - 0 to 10 V DC, 0/4 to 20 mA DC
 - Resistance 500 Ohm, resistance 30 kOhm
- 4 relay-outputs (each potential-free changeover contact)
- Ethernet interface (http, https, UDP, MODBUS, Bonjour, UpNP, SNMP)
- RS485 interface (Standard Ziehl- and MODBUS RTU protocol)
- Universal power-supply 24 to 240 V AC/DC
- Integrated Web server for configuration, read-out of measured data, user-management email-alarms, data- and alarm-logging
- Time-dependent control (day/night)
- Real-time clock with synchronization with time server.

Application

Communication with one TR800 Web via Ethernet interface

If one universal relay TR800 is sufficient for the measured-value capturing, it may be connected directly to the protection device with a CAT5 patch cable (e.g. 7SK80x/Port A). The setting of the TR800 Web is done prior to connection with the same cable via a PC using a Web browser. A TR800 can also be interrogated by two or more SIPROTEC devices. IP-address and the UDP-Port of the TR800 may be set in the SIPROTEC device. In this way, one SIPROTEC device may use temperatures 1 – 3 and another device can use the temperatures 3 – 6 for processing. Each device, however, reads in all 6 temperature values (Fig. 13/48b).

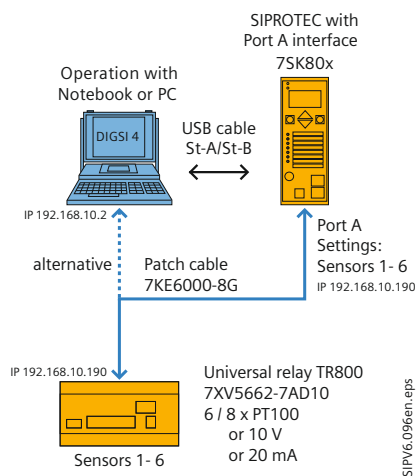

Fig. 13/48b
Connection of one device via Ethernet

Communication with two TR800 Web via Ethernet interface

If two TR800 are applied on big motors for the purpose of measured-value capturing, a substation hardened switch (e.g. RUGGEDCOM RS900 or Hirschmann RSR20) must be used. The switch, the two TR800 Web relays, the protection device and the operating PC constitute an autonomous subnet when they are connected via patch cables (1:1). They may also be part of a larger Ethernet network.

DIGSI 4 and Web browser can run in parallel on the operating PC. Accordingly, one of the two TR800 Web and the protection device can be applied and read out during normal operation. (Fig. 13/48c).

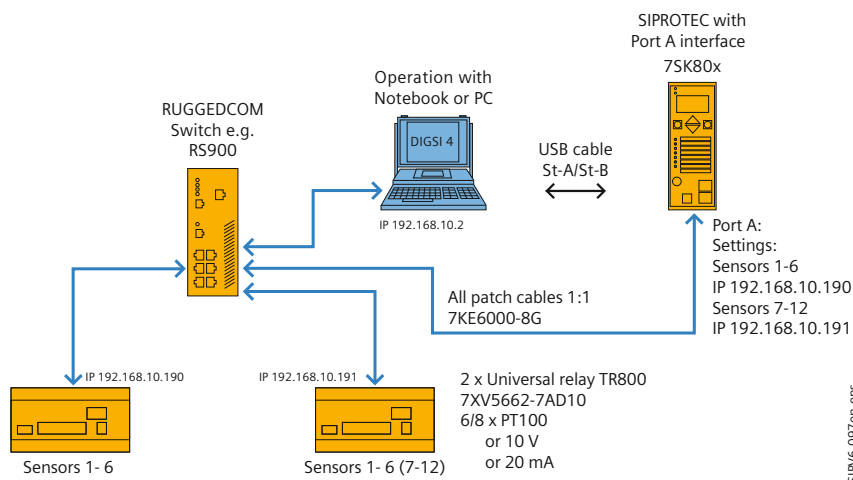

Fig. 13/48c
Connection of two devices via Ethernet

Communication via RS485 bus

One or two TR800 may be connected via a RS485 interface to a SIPROTEC 4 device with thermo function (7SJ6, 7UT6, 7UM6), or the compact device 7SK80.

For connection purposes the special cables 7XV5103-7AAxx are used. In the case of remote measuring points a connection can also be established via a multi-mode FO cable and the converter 7XV5650.

For different applications, 3 modes of operation are available. All three modes are compatible with thermo box TR600 with 6 measuring inputs. The mode of operation is set via the RS485 address of the TR800 Web.

For detailed information please visit www.siemens.com/siprotec

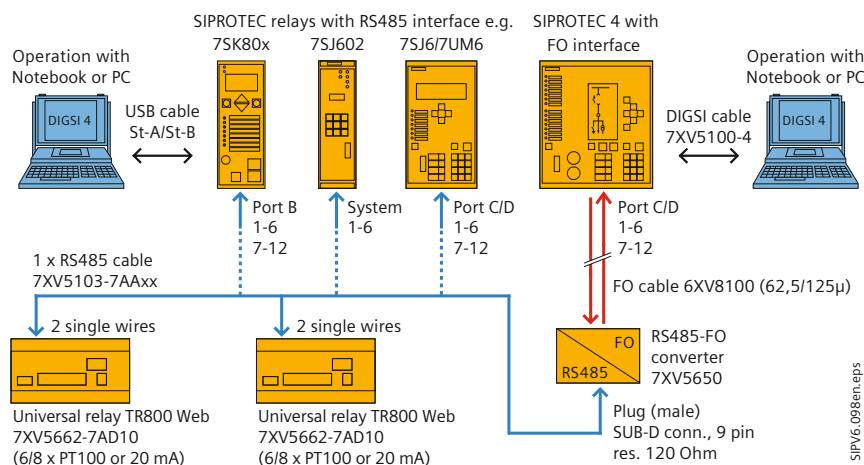

Fig. 13/48d
Connection via serial RS485 bus or FO cable

Technical data

Rated auxiliary voltage					
Auxiliary voltage V_S :	24 to 240 V AC/DC, 0/45 to 120 Hz < 4 W < 8 VA				
Tolerance	20.4 to 297 V DC, 20 to 264 V AC				
Insulation	2000 V AC				
Relay output					
Number	4 x 1 changeover contact (CO)				
Switching voltage	Max. 415 V AC				
Switching current	Max. 5 A				
Switching power	Max. 2000 VA (ohmic load) Max. 120 W at 24 V DC				
De-rating factor with $\cos \varphi = 0.7$	0.5				
U_L electrical ratings:	250 V AC, 3 A general use 240 V AC 1/4 hp. 2.9 FLA 120 V AC 1/10 hp. 3.0 FLA C 300 D 300 1 A 240 V AC				
Rated operating current I_E	AC 15 DC 13	$I_E = 3$ A	$V_E = 250$ V		
		$I_E = 2$ A	$V_E = 24$ V		
		$I_E = 0.2$ A	$V_E = 125$ V		
		$I_E = 0.1$ A	$V_E = 250$ V		
Recommended fuse	T 3.15 A (gL)				
Contact service life, mech.	3×10^7 switching operations				
Contact service life, electr.	1×10^5 switching operations at 250 V AC / 6 A				
Real-time clock					
Buffered for 7 days. Continuous synchronization via SNTP on the Ethernet interface is possible					
Test conditions					
Acc. to	EN 61010-1				
Rated impulse voltage insulation	4000 V				
Pollution rate	2				
Rated insulation level V_i	300 V				
Duty cycle	100 %				
Perm. ambient temperature	-20 °C to +65 °C EN 60068-2-1 dry heat				
Seismic safety EN 60068-2-6	2 to 25 Hz ± 1.6 mm 25 to 150 Hz 5 g				
Electrical isolation	Ethernet – measuring input min. 500 V DC				
No electrical isolation	RS 485 interface – measuring inputs				
EMC tests	EN 61326-1				
EMC test for noise emission	EN 61000-4-3				
Fast transient disturbances/Burst	EN 61000-4-4 ± 4 kV Pulse 5/50 ns, $f = 5$ kHz, $t = 15$ ms, $T = 300$ ms				
High-energy surge voltages (SURGE)	IEC 61000-4-5 ± 1 impulse: 1.2 / 50 μ s (8/20 μ s)				
Electrostatic discharge	IEC 61000-4-2 ± 4 contact discharge, ± 8 kV air discharge				
Ethernet connection	10/100 MBit Auto-MDIX (no cross-over cable required)				
Sensor connection					
Measuring cycle/measuring time (for 8 measured values)	< 3 s				
Pt100, Pt1000 according to EN 60751:					
	Measured range °C		Short circuit Ohm	Interruption Ohm	Sensor resistance + circuit resistance Ohm
Sensor	min.	max.	<	>	max.
Pt 100	-199	860	15	400	500
Pt 1000	-199	860	150	4000	4100
When connecting Ni100 or Ni120 sensors, the conversion is done in the SIPROTEC device. The TR800 is configured with Pt100 sensors.					

Technical data

Sensor connection (cont'd)

Accuracy	± 0.5 % of measured value ± 0.5 K
Sensor current	≤ 0.6 mA
Temperature drift	< 0.04 °C/K

Voltage/current input

	Input resistance	Maximum input signal	Accuracy of final value
0 – 10 V	12 k Ω	27 V	0,1 %
0/4 – 20 mA	18 Ω	100 mA	0.5 %

Temperature drift	< 0.02 %/K
-------------------	--------------

Resistance measurement

Accuracy 0.0 ... 500.0 Ω	0.2 % of measured value ± 0.5 Ω
Accuracy 0 ... 30.00 k Ω	0.5 % of measured value ± 2 Ω
Sensor current	≤ 0.6 mA

Housing

Housing type	V8, distribution panel mounting
Size (W x H x D)	140 x 90 x 58 mm
Depth/Width	55 mm/8 TE
Circuit termination single strand	Per 1 x 1.5 mm ²
Braided conductor with crimp lug	Per 1 x 1.0 mm ²
Tightening torque of terminal screw	0.5 Nm (3.6 lb.in)
Degree of protection of housing/terminals	IP30 / IP20
Mounting vertical/horizontal	Optional
Affixing	Snap-on mounting onto standard rail mounting 35 mm acc. to EN 60715 or screw mounting (with 2 additional brackets)
Weight	Approx. 370 g

Selection and ordering data

Description	Order No.
<i>Universal relay/RTD-box TR800</i>	<i>7XV5662-7AD10</i>

Distributed input-box for 6/8 RTD-connections (RTD-box) or 6/8 x 20 mA, or 0 – 10 V

Rail mounting plastic

Protection class IP21

1 serial interface RS485 for communication of measurements

1 RJ45 interface for parameter setting via Web browser and communication of measurements

Wide-range power supply 24 to 240 V AC/DC

Note: The device can be operated in a 7XV5662-2AD10 or 7XV5662-5AD10 compatible mode.

7XV5662-8AD10 Resistance Temperature Detector (RTD-Box) TR1200 IP (Ethernet)



Fig. 13/49a
7XV5662-8AD10 RTD-box TR1200 IP (Ethernet)

Description

The RTD-box TR1200 IP has 12 sensor inputs which allow measurement of up to 12 temperatures by Pt100 sensors.

Three conductor sensors are supported. For two conductor operation compensation of the measured conductor resistance is possible via a corresponding setting.

All settings on the TR1200 IP can be done through 3 keys on the front of the device or in a Web browser (e.g. Internet Explorer).

If Ni100 or Ni120 sensors are applied, the measured values have to be adapted in the protection device. The 7SK80 supports this with its integrated RTD functionality.

The measured-value output to the protection device is done via Ethernet network with RJ45 connectors.

Note: The SIPROTEC 4 system interface with EN100 module does not support the temperature detection of the RTD-box TR1200 IP.

Function overview

- 3-digit digital display for the temperature of up to max. 12 measuring points
- 12 sensor inputs; 1 to 12 sensors can be connected
- PT100 in 2- or 3-conductor technology, when connecting Ni100 or Ni120, conversion to the correct temperature in the evaluation unit is required, SIPROTEC devices (e.g. 7SK80) support this function. The EN100 module in the SIPROTEC 4 units does not support the TR1200 IP
- 1 alarm relay (1 changeover contact)
- Electric 10 MBit/s Ethernet interface (RTD IP protocol from ZIEHL, or MODBUS IP protocol)
- Read-out display, configuration, simulation and firmware update via Web browser
- Tested with Mozilla Firefox 3.5 and Microsoft Internet Explorer 8.0
- LEDs for measurement allocation, error, relay status and Ethernet interface
- Code protection against manipulation of the setpoint values
- Wide-range power supply 24 to 240 V AC/DC
- Distributor housing for panel mounting 8 TE, front-to-back size 55 mm
- Mounting on 35 mm DIN EN 60715 standard rail.

Application

Measurement of up to 12 measured values with a TR1200 IP

To get up to 12 measured values one RTD-box TR1200 IP is connected via a double screened CAT5 patch cable (1:1 or crossed-over) directly to the protection device (e.g. 7SK80x/Port A).

The protection device is set using DIGSI 4 program running on a Notebook via the USB-front interface.

The RTD-box TR1200 IP is set either through the front keys or by using a Web browser running on the Notebook via the Ethernet interface. For this purpose the patch cable must be unplugged from the protection device and then re-plugged into the Notebook.

Tip: If during commissioning a common switch is temporarily inserted using three patch cables, the protection device can be set from a PC using DIGSI 4 in parallel with the TR1200 IP.

For detailed information please visit:
www.siemens.com/siprotec

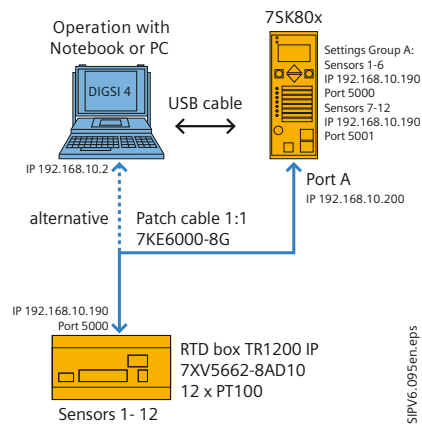

Fig. 13/49b
Connection of a device via Ethernet

Technical data

Rated voltage

Control voltage V_S :	24 to 240 V AC/DC, 0/45 to 65 Hz < 5 VA 20.4 to 297 V DC, 20.4 to 264 V AC
-------------------------	---

Relay output

Number	1 changeover contact (CO)	
Switching voltage	Max. 415 V AC	
Switching current	Max. 5 A	
Breaking capacity	Max. 2000 VA (resistive load) Max. 120 W at 24 V DC	
Reduction factor at $\cos \varphi = 0.7$	0.5	
U_L electrical ratings:	250 V AC, 3 A general use 240 V AC 1/4 hp. 2.9 FLA 120 V AC 1/10 hp. 3.0 FLA C 300 D300 1 A 240 V AC	
Rated operating current I_E	AC 15	$I_E = 1 \text{ A}$ $V_E = 400 \text{ V}$ $I_E = 2 \text{ A}$ $V_E = 250 \text{ V}$
	DC 13	$I_E = 2 \text{ A}$ $V_E = 24 \text{ V}$ $I_E = 0.2 \text{ A}$ $V_E = 125 \text{ V}$ $I_E = 0.1 \text{ A}$ $V_E = 250 \text{ V}$
Recommended series fuse	T 3.15 A (gL)	
Contact service life, mech.	1×10^7 operating cycles	
Contact service life, electr.	1×10^5 operating cycles at 250 V AC / 5 A 2×10^5 operating cycles at 250 V AC / 3 A 6×10^5 operating cycles at 250 V AC / 1 A	

Temperature measurement

Measurement time sensor	0.25 to 3 s (dependent on the number of sensors)
Measurement time sensor	0.25 to 30 s (for measurement cycle of one sensor)
Measurement range	-199 °C to 850 °C
Resolution	1 °C

Technical data

Sensor connection

12 x PT100 acc. to EN 60751, connection of Ni100 and Ni120 sensors possible. Conversion of the measured values must be performed in the evaluation unit.

Sensor	Measured range °C		Short circuit Ohm	Interruption Ohm	Sensor resistance + line resistance Ohm
	min.	max.	<	>	max.
Pt100	-199	860	15	400	500

Tolerance $\pm 0.5\%$ of measurement $\pm 1\text{ K}$

Sensor current $\leq 0.8\text{ mA}$

Temperature drift $< 0.04\text{ °C/K}$

Ethernet interface

Transmission speed	10 MBit/s
IP address	Standard: 192.182.1.100, adjustable
Subnetwork mask	Standard: 255.255.255.0, adjustable
UDP port	Standard: 5000 (5001), adjustable
Max. cable length	20 m when using CAT 5 patch cable
Max. response time RTD/MODBUS	$< 700\ \mu\text{s}$

Test conditions

Acc. to	EN 61010
Rated impulse withstand voltage	4000 V
Surge category	III
Pollution level	2
Rated insulation voltage V_i	300 V
Operating time	100 %
Permissible ambient temperature during operation	-20 °C to $+65\text{ °C}$ EN 60068-2-2 dry heat
EMC – noise immunity	EN 61000-6-2
EMC – noise emission	EN 61000-6-4
Galvanic insulation	
Control voltage – measurement input	3820 V DC
Ethernet – control voltage – measurement input	500 V DC

Housing

Housing type	V8, distribution panel mounting
Dimensions (W x H x D)	140 x 90 x 58 mm
Front-to-back size/Width	55 mm/8 TE
Wiring connection single strand	Each $1 \times 1.5\text{ mm}^2$
Finely stranded with wire end ferrule	Each $1 \times 1.0\text{ mm}^2$
Starting torque of the terminal screw	0.5 Nm (3.6 lb.in)
Protection class housing/terminals	IP30 / IP20
Mounting position	Arbitrary
Mounting	Snap-on mounting onto standard rail 35 mm acc. to EN 60715 or screw mounting (with 2 additional bars)
Weight	Approx. 350 g

Selection and ordering data

Description	Order No.
<i>Resistance temperature detector (RTD-box) TR1200 IP (Ethernet)</i>	<i>7XV5662-8AD10</i>
Distributed input-box for 12 RTD-connections Pt100	
Rail mounting plastic	
Protection class IP21	
1 Ethernet interface for communication with SIPROTEC devices for measurement and fault reports.	
Wide-range power supply 24 to 240 V AC/DC	

7XV5664 / 7XV5654 GPS/DCF77 Time Synchronization System

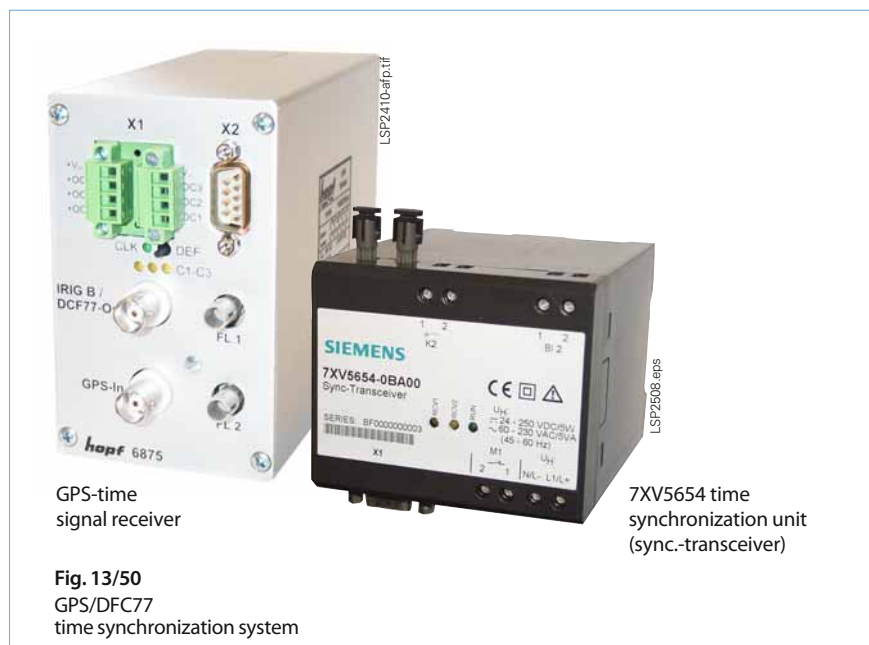

GPS-time
signal receiver

7XV5654 time
synchronization unit
(sync-transceiver)

Fig. 13/50
GPS/DCF77
time synchronization system

Description

With the GPS-time signal receiver 7XV5664 and additional components wide-range power supply 7XV5810, mini star-coupler 7XV5450 and sync-transceiver 7XV5654, a comprehensive solution for time synchronization of any number of SIPROTEC protection devices is possible. A simple PC-Software (included in the scope of delivery) facilitates the setting of the receiver via a RS232 interface. The transmission of the time signals (telegrams or impulses) takes place, immune to disturbances, via a FO cable to the protection cubicles, where the time signals are electrically converted with the Sync-Transceiver. The standard version can, with the output of special protocols, also be used for the synchronisation of further devices, e.g. Reyrolle ARGUS 1 or SIMEAS Q80. For the SIPROTEC line differential protection 7SD52 or for SIMEAS R-PMU, the special version provides a highly accurate pulse per second. The GPS antenna with 25 m cable to the receiver is included in the scope of delivery. Lightning protection is optionally available.

Features/function overview

- GPS exterior antenna with wall mounting and 25 m cable RG59, lightning protection is optional
- GPS-antenna input (BNC-plug)
- PC-input, RS232 (9-pol. Sub-D plug) with operating program and 1m connection cable
- 2 optical signal outputs FL1/2 for FO cable 62,5/125 µm and ST-plug for disturbance free transmission of the signals
- Auxiliary voltage 18-60 V DC / optionally with wide-range power supply 7XV5810-0AA10, 24-250 V DC / 100-230 V AC.
- Aluminium housing for rail mounting.

Standard Version 7XV5664-0CA00:

- Signal outputs FL1/2: telegrams selectable IRIG-B, DCF77-, NMEA, IEC60870-5-103, second or minute impulses.
- 3D-mode with at least 4 satellites or Fix-mode with at least 1 satellite.

Special Version 7XV5664-0AA00:

- Signal outputs FL1/2: fixed telegrams
FL 1 = highly accurate second impulse
FL 2 = IRIG-B or DCF77
- Only 3D-mode with at least 4 satellites.

Application

The “Normal Time” standard application

With the GPS-time signal receiver 7XV5664-0CA00 all connected protection devices are synchronized to “Normal Time”. In this way, the internal clock of the protection devices is synchronized by a standardized telegram e.g. IRIG-B, DCF77, IEC60870-5-103, NMEA or a minute impulse.

For this purpose the protection devices provide suitable interfaces e.g. SIPROTEC 4 provides Port A.

The antenna is mounted to an outside wall with free sight to the sky and the optional lighting protection is looped into the antenna cable.

The GPS-time signal receiver is mounted close to the antenna, and is either supplied with auxiliary voltage via the optional wide-range power supply from the AC mains, or the substation battery.

The transmission of the time telegrams or synchronizing impulses takes place, immune to interference, with FO cable to the protection devices distributed in the plant. An extension of the optical star structure can be implemented with the mini star-coupler 7XV5450. For the conversion of the FO signals to 24 V signals as required by the SIPROTEC 4 time synchronization interfaces (Port A), sync-transceivers 7XV5654 are implemented.

Detailed application examples may be found in the manual of the sync-transceivers 7XV5654.

The SIPROTEC 4 protection devices are connected to the sync-transceiver 7XV5654 via “Port A” with the specially designed bus cable system 7XV5104 (see Fig.13/51). Note: No bus termination resistance is required here.

All SIPROTEC protection devices with internal clock

may be synchronized with the minute impulse from the GPS receiver via a binary input. For this purpose the internal clock of the protection device is set at each full minute to the exact beginning of the new minute. A pre-condition for this method is that the internal clock of the protection device is set correctly once, and the auxiliary voltage is buffered against failure. If the time tracking fails for a longer period, the difference between the internal clock of the protection device and the normal time

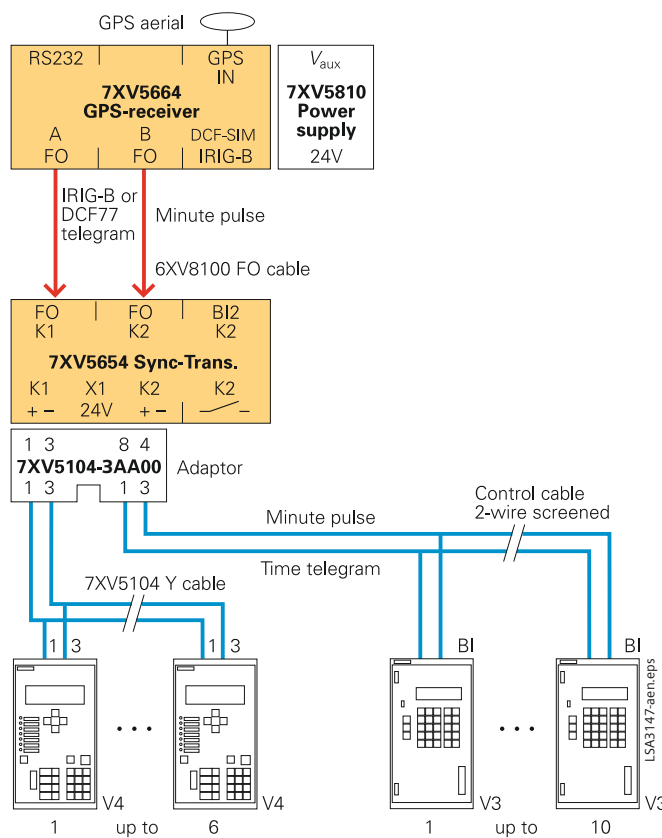

Fig. 13/51 SIPROTEC 4 protection unit with GPS-time synchronization

must be smaller than one minute. Daylight saving time must, if desired, be set manually.

Protection devices are fitted with a binary input, which captures the minute impulse using a corresponding voltage (24-60 or wide range 24-250 V DC) and provides this to the internal clock. The distribution of the impulse to the protection devices takes place via a 2-wire bus, which must consist of a screened twisted pair. All devices must be located in the same earthed system, the cable screens must be connected to the housing on both sides.

If both channels of the GPS-receiver are set to the minute impulse, up to 20 SIPROTEC 3 devices may be connected. Alternatively, a coupling of both output channels of the sync-transceivers with the DIL-switches S1/3 is possible.

Selection and ordering data

Description	Order No.
<i>GPS-time signal receiver</i>	7XV5664-0□A00
<i>GPS-timing signal receiver "Special Version"</i> for the time synchronization of SIPROTEC 4 differential prot. devices or SIMEAS R-PMU (Phasor Measurement Unit), with 25 m coaxial cable, PC software with cable (without wide range power supply unit 7XV5810-0BA00)	A
<i>GPS-timing signal receiver "Standard-Version"</i> for the time synchronization of SIPROTEC 4 protection devices, with 25 m coaxial cable, PC software with cable (without wide range power supply unit 7XV5810-0BA00)	C
Lightning protection with plugs for connection to the antenna cable	L
<i>Additional accessories for time synchronisation</i>	
<i>Wide-range power supply (universal)</i> Universal supply voltage (48...250 V DC ± 20 %, 60...230 V AC ± 20 %) Output voltage 24 V DC / 6 W, short-circuit proof, alarm contact	7XV5810-0BA00
<i>Sync-transceiver</i> Sync-transceiver for conversion of 2 optical timing signals to 24 V DC for the time synchronizing interface of SIPROTEC 4 (Port A) 2 optical inputs with ST-plugs and 2 electrical outputs for max. 12 SIPROTEC 4 relays or 20 SIPROTEC 3 relays. Minute or second pulse for special applications is also supported.	7XV5654-0BA00
<i>Y-bus cable for time synchronizing SIPROTEC 4 (standard)</i>	7XV5104-0AA□□
Y-bus cable 2-core screened with 9 pole sub-D connector and metallic housing for clock synchronization SIPROTEC 4	
Length 1 m	0 1
Length 3 m	0 3
Length 5 m	0 5
Length 10 m	1 0
<i>Bus length extension cable (standard)</i> Cable for the bus length extension. Copper cable with 2-wires, shielded with 9-pole sub-D plugs. Length 10 m	7XV5104-1AA10
<i>Adapter cable to sync.-transceiver 7KE6000-8 (standard)</i> Adapter cable to sync.-transceiver 7KE6000-8Ax. Length 0,3 m. Shielded, 2-wires with crimp lugs to 9-pole sub-D plug (female)	7XV5104-2AA00
<i>Adapter cable for 2 busses (standard)</i> Adapter cable 2 core screened for sync-transceiver 7XV5654-0BA00 for distribution of 2 busses for each 6 SIPROTEC 4 relays	7XV5104-3AA00
<i>Y-bus cable for time synchronizing SIPROTEC 4 Diff.-protection and SIMEAS R-PMU (special)</i>	7XV5105-0AA□□
Y-bus cable 2-core screened with 9 pole sub-D connector and metallic housing for clock synchronization SIPROTEC 4, e.g. 7SD5	
Length 1 m	0 1
Length 3 m	0 3
Length 5 m	0 5
Length 10 m	1 0
<i>Bus length extension cable (special)</i> Cable for the bus length extension. Copper cable with 4-wires, shielded with 9-pole sub-D plugs. Length 10 m	7XV5105-1AA10

7XV5673 I/O-Unit with 6 Binary In-/Outputs



Fig. 13/52
7XV5673 I/O-Unit – binary I/O mirror, -binary I/O expansion, -contact multiplier

Description

I/O-Unit 7XV5673 is a binary input/output device and is designed for substations and increased industrial environment requirements. The I/O-Unit allows the transmission of binary inputs to binary outputs locally or via long distances. It can be used for protection applications, e.g. overcurrent protection, signal comparison, teleprotection or as I/O-expansion in substation automation systems.

Function

Via binary inputs, all kinds of binary signals of switchgear/ protection scheme (for example tripping commands, switch position signal, fault and status indications) are securely detected. This information can directly be distributed at this I/O-Unit via contacts, or be transmitted via communication links to further I/O-Units or to automation systems.

Secured telegrams are used for the communication via Ethernet or serial connections. The parameter setting of the I/O-Unit is simply carried out with a standard Web browser at the PC which is connected by the Ethernet interface.

The I/O-Unit can be set as:

- I/O mirror: Point-to-point transfer of binary signals between two I/O-Units via Ethernet or a serial connection. Signal inputs and outputs assignable by the user.
- I/O expansion: Expansion of substation controllers by binary inputs and outputs using standard protocols.
- Contact multiplier: Distribution of signals on one or several binary inputs via relay contacts of the same I/O-Unit, e.g. for isolation between different voltage levels.

Feature overview

- Binary inputs
 - 6 ruggedized EMC – hardened binary inputs
 - Pickup voltage threshold settable to 19 V DC, 88 V DC or 176 V DC for different station battery voltages
- Binary outputs
 - 6 command relay outputs
 - Safe state of contacts after loss of connection settable by the user
- Signal/Alarm outputs
 - 4 LED
- Wide-range power supply
 - 24-250 V DC +/- 20 % and 100-230 V AC 45-65 Hz
- Electrical RJ45 Ethernet interface
 - Cascading many devices without additional costs by the use of the integrated switch
- Serial fiber-optic interface (optional)
 - ST-connector, 820 nm for multi-mode fiber 62.5/ 125 μm, typical range 2000 m using fiber 62.5 μm/125 μm, baud rate 1.2 kBit/s – 187.5 kBit/s settable per software
- Serial RS485-interface (optional)
 - Sub-D plug, 9-pole female
- Protocols, communication
 - MODBUS TCP or MODBUS RTU for connection to a substation controller
 - MODBUS UDP for point-to-point connections between two I/O-Units
 - Sntp for time synchronization
 - IEC 61850* (GOOSE and Reporting)
- Housing
 - IP20 rail mounting
- Standards
 - CE, UL, IEC 60255, IEEE 61000 ...
- Environmental conditions
 - EMC hardened binary I/O for substation environment
 - Extended high temperature range up to 85 °C (16 h/day).

Operation features

- Easy parameterization with a standard Internet browser (no special software required)
- Password protection against unauthorized access
- Monitoring of data errors, loss of connection, transfer time and the state of BI, BO.
- Time synchronization with SNTP-Protocol with 1 ms resolution from an external time server over Ethernet. Redundant time servers are supported
- Buffer battery changeable from the front
- Fast I/O mirror: Fast transmission time from BI pickup to contact closing between two I/O-Units typically 11 ms for high bandwidth connection
- Connection to a substation controller over MODBUS TCP, MODBUS RTU or IEC 61850 protocol *
- Blocking of data transmission with a binary input for testing
- Battery buffered operational event log with 1 ms resolution time stamp
- Assignment of BI / BO signals which shall be logged into the operational buffer
- Integration into network management systems with SNMP – protocol and provided MIB – files.

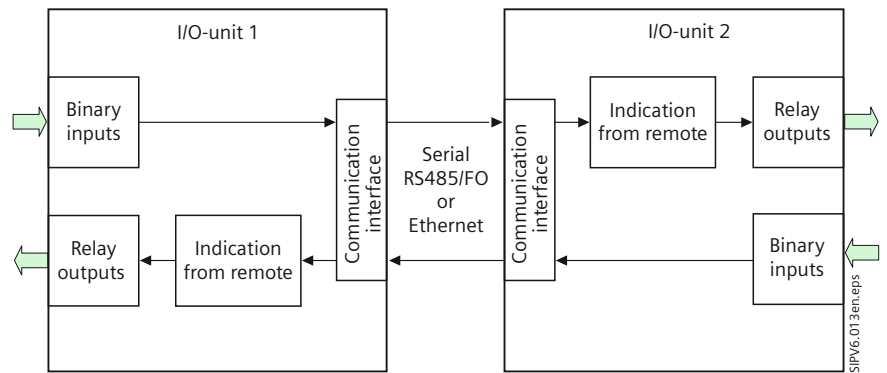

Fig. 13/53 I/O mirror, bi-directional transmission between two devices

Application

I/O mirror function

When using the I/O-Units as I/O mirror according to Fig. 13/53, the devices transmits the binary signals bi-directional. The transmission takes place between the two devices over serial links (option) or over Ethernet networks.

Via the relay output contacts voltages up to 250 V AC/DC and currents up to 5 A AC/DC can be switched. The pick threshold of the binary inputs can be set by the user on different levels.

Signal inputs and outputs can be assigned by the user.

Extension of the transmission distance

An extension of the transmission distance is possible. The following devices can be used:

- With serial optical repeater 7XV5461 scalable up to 170 km
- RS485-FO Converter 7XV5650 for cascading devices
- With different communication converters.

* In preparation

Application

Uni-directional binary signal transmission

When using the I/O-Units for uni-directional binary signal transmission according to Fig. 13/54, the devices transfer binary signals unidirectional from one device to several devices. In this application, the transmission only takes place in one direction. Input signals (max. 6) from the left unit are sending to output contacts of one or more units on the right side.

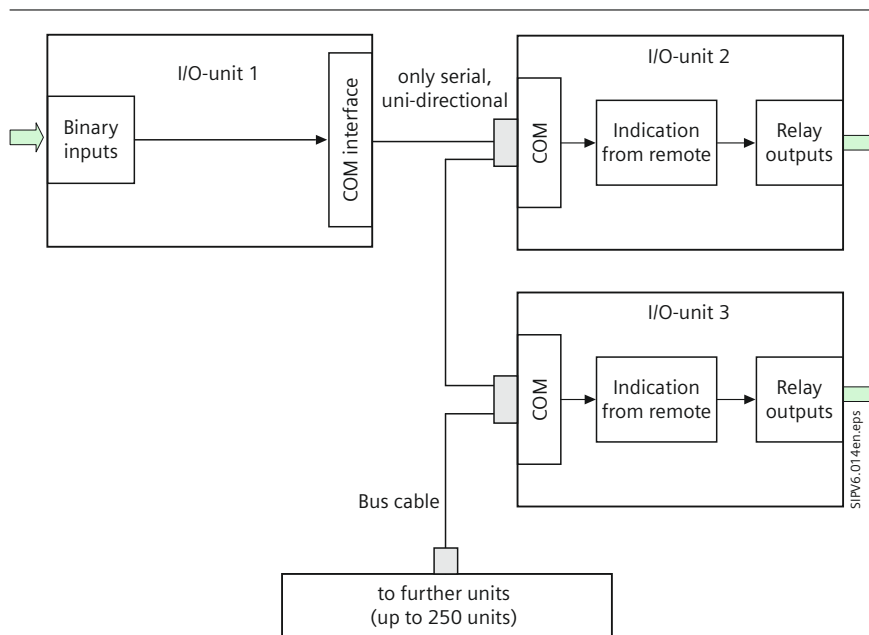
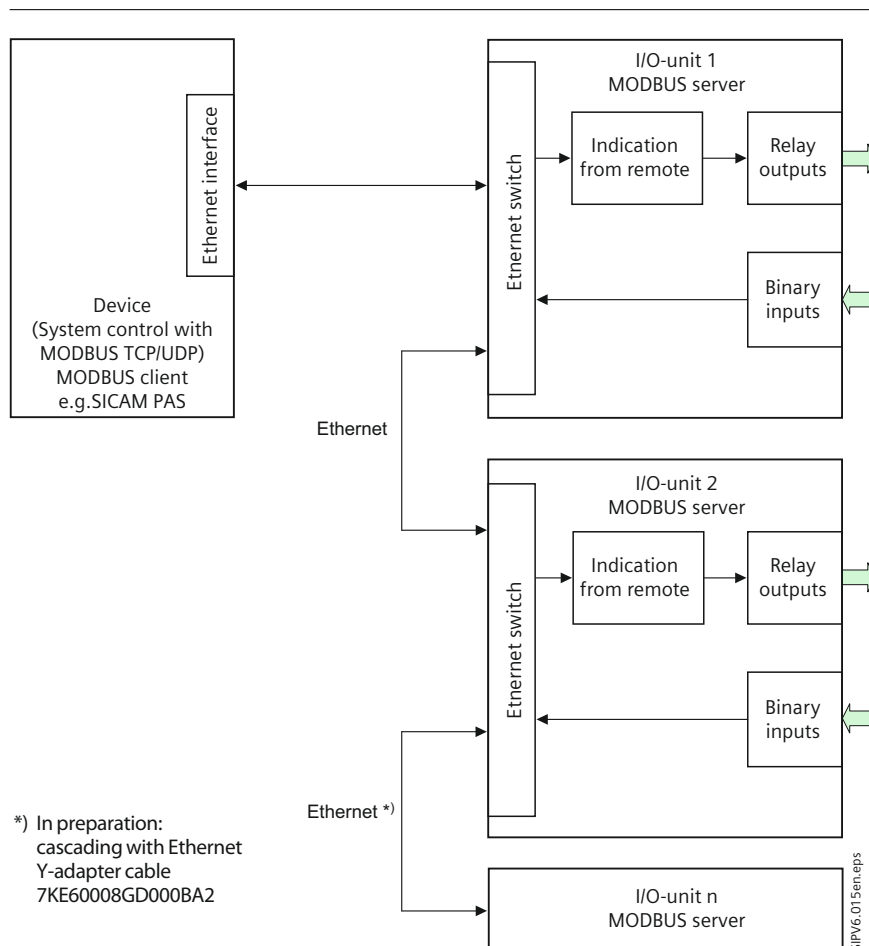

Fig. 13/54 I/O mirror, uni-directional transmission from one to multiple I/O-Units

I/O expansion of a substation controller

The I/O-Unit is used as I/O expansion, according to Fig. 13/55. Binary signals are exchanged between a substation controller (e.g. SICAM PAS) and the I/O-Units by using the MODBUS TCP protocol over an Ethernet network. If the integrated switch in the I/O-Unit is used, the units can be operated in a line without using additional external switches as shown in Fig. 13/85. Also IEC 61850 client server communication will be provided in future.



*) In preparation:
cascading with Ethernet
Y-adapter cable
7KE60008GD000BA2

Fig. 13/55 I/O expansion of a substation controller with binary inputs and outputs

Application

Instead of using an Ethernet network there is also the option of serial connection with MODBUS RTU protocol. The link can be done by a RS485-bus line structure or an optical star network.

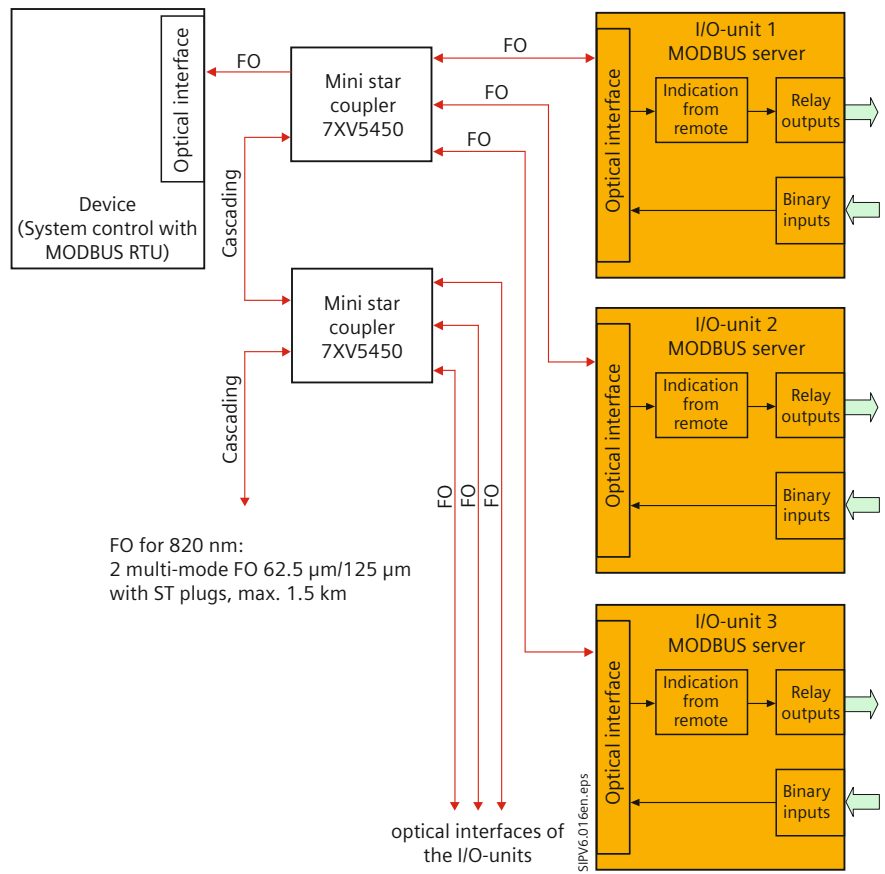

Fig. 13/56 I/O expansion for the connection to substation controller using a serial optical star topology

Application

Contact multiplier

Input signals on one or more binary inputs can be assigned to binary outputs of the local device (Fig. 13/57)

- 1 binary signal on up to 6 relay outputs
- Several binary signals to several relay outputs assignable by the user
- Different voltage levels for inputs and outputs in a wide voltage range to isolate between different voltage levels.

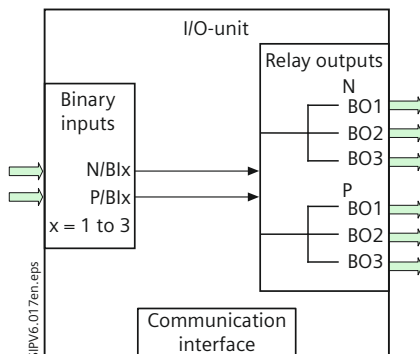

Fig. 13/57 Contact multiplier

Applications for remote transmission of binary signals

Binary signal transmission via communication networks using a G.703.1/X.21 interface

The picture shows the optical connection of an I/O-Unit to a communication converter (KU-XG) 7XV5662-0AA01, which establishes a connection to a multiplexer with G.703.1 or X.21 interface. This allows the use of this communication converter to transfer the signals via communication network. The average delay time in the network and the signal quality is monitored by the I/O-Unit. Also loss of connection is indicated. In this case, the state of the binary outputs can be set by the user to a safe condition depending on the application.

A maximum of 6 binary single signals can be transmitted bi-directional via the communication network.

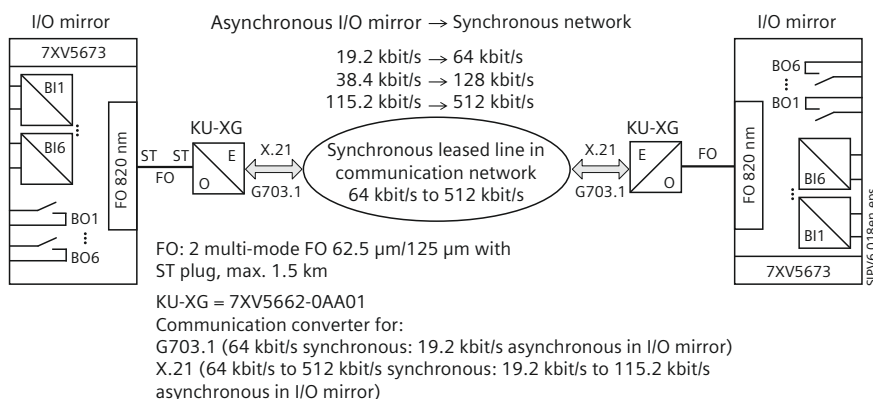

Fig. 13/58 Binary signal exchange over a communication converter with G.703.1/X.21 interface via a communication network

Application

Binary signal transmission via two-wire copper cable with blocking

The picture shows the optical connection of an I/O-Unit to a communication converter 7XV5662-0AC01, which establishes a connection via pilot wire. Only one pair is necessary for bi-directional signal exchange.

An additional isolation transformer allows 20 kV isolation from the pilot wire connection.

A maximum of 6 binary single signals can be transmitted bi-directionally over the pilot wire. The additional delay caused by the transfer over the communication converter and pilot wire is less than 1 ms.

A typical application is the signal comparison of a directional overcurrent protection device via pilot wires. In this case, the definite time-overcurrent protection device is connected to the I/O-Unit via contacts and binary inputs and directional signals are transferred.

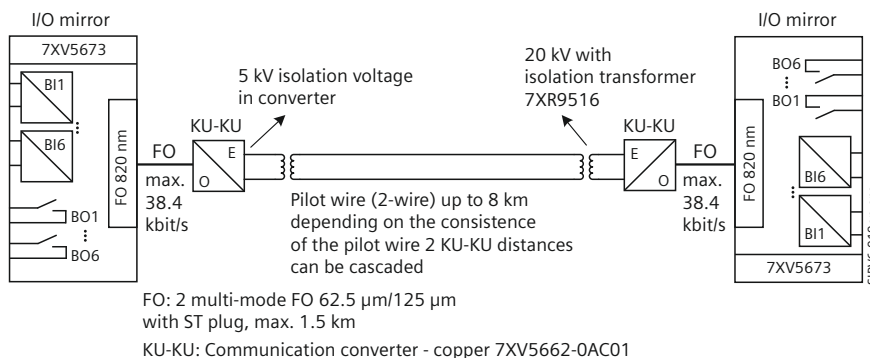

Fig. 13/59 Binary signal exchange of 6 signals via pilot wire connection

Binary signal exchange of over long fiber optic links

The figure shows the optical connection of an I/O-Unit to a serial optical repeater 7XV5461-0BX00, which establishes a connection to multi-mode or single-mode fiber cables. A max. distance of 170 km can be reached with this application without additional amplifiers.

A maximum of 12 binary signals can be exchanged via long fiber optical connections because the repeater allows connecting two I/O-Units.

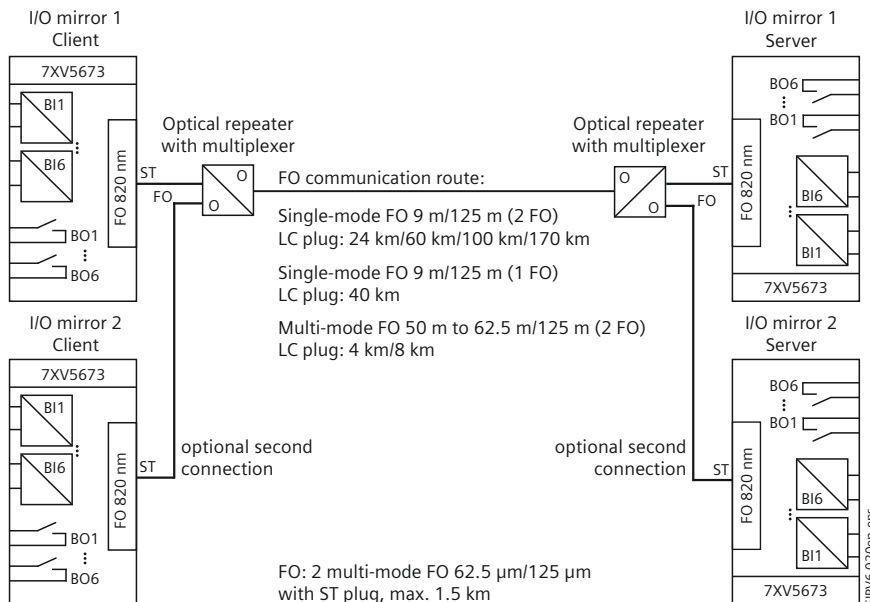

Fig. 13/60 Binary signal exchange of up to 12 signals over long fiber optic links

Application

Binary signal transmission via a communication networks using a G.703.6 interface

The figure shows the optical connection of one up to three I/O-Units to a communication converter KU-2M 7XV5662-0AD00, which establishes a connection to a multiplexer with a G.703.6 interface (1.44 kbit/s/2 Mbit/s, E1/T1).

A maximum of 18 binary single signals can be transmitted bi-directionally over the communication network. The KU-2M is provided with two optical and one electrical RS232 interface. Two I/O-Units can be directly connected by an optical cable to the KU-2M. On the RS232 interface, an additional I/O-Unit can be connected via an optoelectronic converter. Using all input interfaces (2 FO, 1 RS232) of the KU-2M, a maximum of 18 signals can be exchanged bi-directionally.

For long distance connections via Ethernet media converters or Ethernet networks can be used. The I/O-Unit supports IP – address settings and settings for a standard gateway. The electrical Ethernet interface of the I/O-Unit is connected to a media converter or switch which transfer the signals of the units over long distance Ethernet connections. The average delay time in the network is measured by the I/O-Unit.

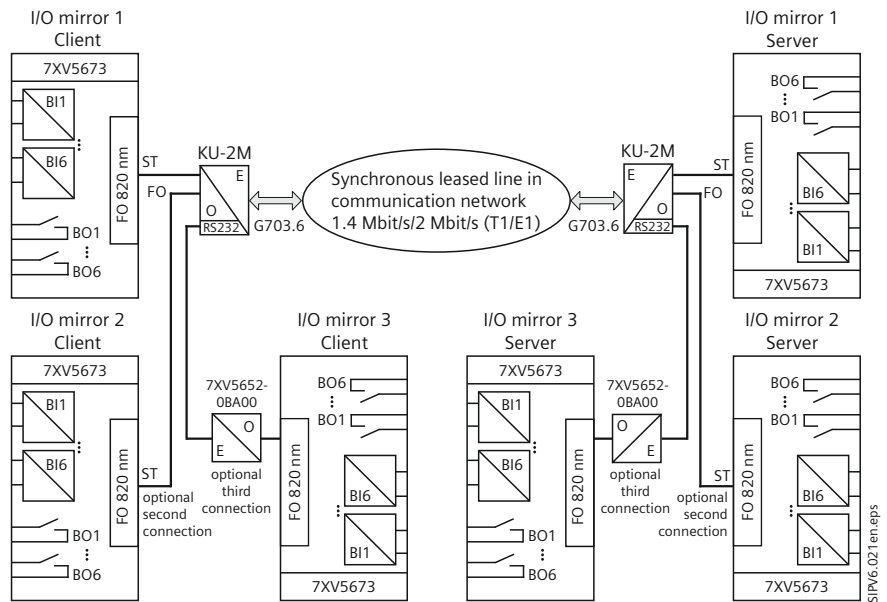

FO: 2 multi-mode FO 62.5 μm/125 μm with ST plug, max. 1.5 km
 KU-2M = 7XV5662-0AD00
 Communication converter for: G703.6 (2 Mbit/s synchronous: 115.2 kbit/s asynchronous in I/O mirror)

Fig. 13/61 Binary signal exchange with G.703.6 interface via a communication network

Device configuration

The I/O-Unit is equipped with an integrated Web Server which allows easy setting using standard Internet-Browsers. Fig. 13/62 shows the User interface. All settings are done with the Browser. Also operational log and commissioning aid are supported by the Browser like the indication of the actual state of the inputs and outputs.

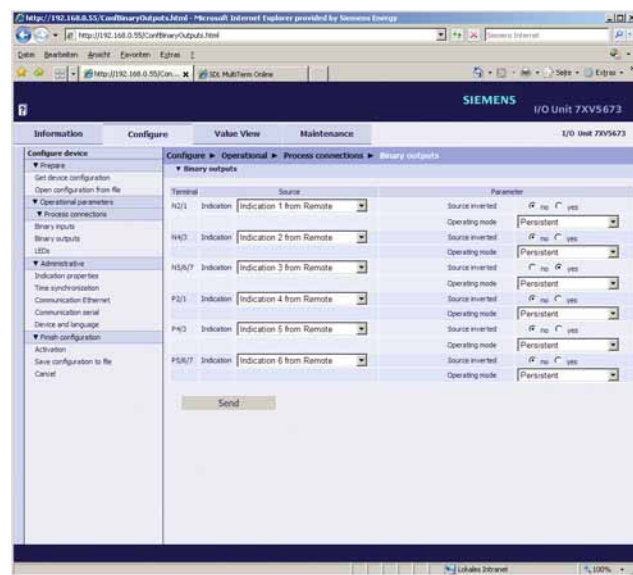

Fig. 13/62 Configuration screen of the I/O-Unit in the Browser

Selection and ordering data

Description	Order No.
<i>I/O-Unit with 6 binary in- and outputs</i>	<i>7XV5673-0JJ□0-1AA1</i>
<i>I/O-Unit with Ethernet interface and RS485-interface</i>	<i>1</i>
<i>optical interface</i>	<i>2</i>



7XV5700 RS232 – RS485 Converter



Fig. 13/63
RS232 – RS485 converter

Function overview

- Minimum baud rate: 9600 baud
- Maximum baud rate: 115 kbaud
- No setting of baud rate necessary
- Compact plug casing
- Power supply via plug in PSU
- Maximum 31 relays at RS485 bus
- Complete set for connecting 1 relay to RS485 bus

Description

Up to 31 SIPROTEC 4 relays with an electrical, bus-capable RS485 interface to a PC for centralized control can be connected via the RS232↔RS485 converter.

The converter is housed in an expanded plug casing. The interfaces are connected to 25-pin female connectors. The auxiliary voltage is supplied via a plug-in power supply unit attached to the side. Auxiliary voltages of 110 or 230 V AC make operation with all common AC networks possible.

A twisted and shielded cable with two wires is required for the RS485 bus. The protection relays are connected to the bus in series. Data transmission at a speed of 19.2 kbaud with a bus length of up to approximately 1000 m is possible.

The converter, plug-in power supply unit and the connecting cable to the first relay are included in the scope of supply.

Applications

The RS232↔RS485 converter allows up to 31 SIPROTEC 4 protection relays with electrical busable RS485 interfaces to be connected to a PC notebook.

The converter is housed in an expanded plug casing. The interfaces are connected to 25 pin female connectors. The RS485 interface has a terminating resistor. The auxiliary voltage is supplied via a plug-in power supply unit attached to the side. Auxiliary voltages of 110 V or 230 V AC make operation with all common AC networks possible.

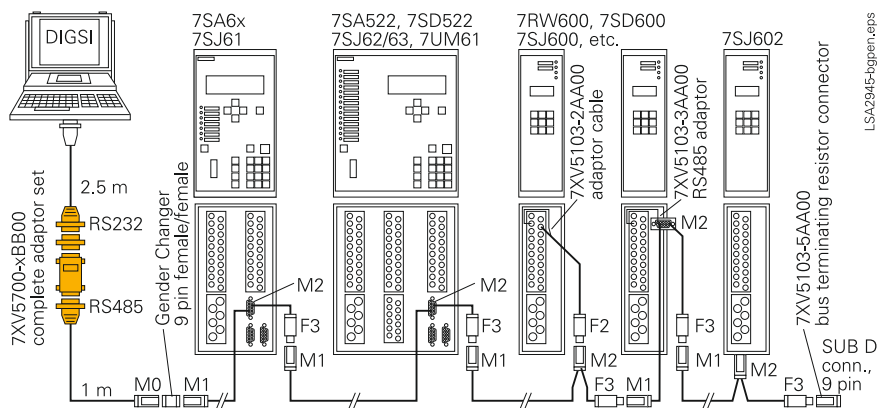

Fig. 13/64 Protection units connected to the RS485 bus

Note

The converter may not be used with a substation modem due to non-existing isolation. It is recommended to use the 7XV5650 and 7XV5651 converters in conjunction with the substation modem.

Functions

The converter works according to the master/slave principle. In idle state, the RS232 interface is inactive while the RS485 interface is switched to the receiving mode. During communication, the PC (master) sends data to the RS232 interface, which are transmitted (half duplex) to the protection unit (slave) by the converter at the RS485 interface. After data transmission, the RS485 interface is once again switched to the receiving mode. Vice versa, data supplied by the protection unit are sent back by the converter to the RS232 interface and to the PC.

No handshake signals are being processed during communication. This means that data sent by the PC are mirrored, which may cause problems in special applications.

Connections

The PC is connected to the converter by means of a DIGSI cable e.g. 7XV5100-2.

A twisted and shielded cable with two wires is required for the RS485 bus. The conductor cross section has to be adapted to the ring cable lugs and the SUB-D connectors. The individual wires protruding from the shield should be kept as short as possible. The shield is connected to the housing earth at both ends. The protection units are connected in series to the bus. The shield between the converter and the protection units, or between the protection units, is connected at both sides. Whenever substantial cable lengths or high baud rates are involved, a terminating resistor of 220 ohm should be applied between signal lines A and B at the last protection unit. Data transmission at a speed of 19.2 kbit/s, with a bus length of up to approx. 1000 m, is possible.

Technical data

Design	
Plug chassis	Plastics
Dimensions	63 x 94 x 16 mm (W x H x D)
Degree of protection	IP20
Power supply	
Power supply	110 or 230 V AC
Via	Plug-in power supply unit
Electrical interfaces	
Type	RS232 to RS485 (non-isolated)
Assignment	See Fig. 13/64
CE conformity, standards	
This product is in conformity with the directive of the Council of the European Communities on the approximation of the laws of the Member States relating to the electromagnetic compatibility (EMC Council Directive 89/336/EEC).	Conformity is proved by tests performed by Siemens AG in accordance with the generic standards EN 50081-1 and EN 50082-2.

Selection and ordering data

Description	Order No.
7XV5700 RS232 – RS485 converter	7XV5700-□□□00
<i>Rated auxiliary voltage</i>	
Via plug-in auxiliary power supply unit (PSU) 230 V / 50 Hz AC	0
Via plug-in auxiliary PSU 110 V / 60 Hz AC	1
<i>Connecting cable</i>	
With RS485 connecting cable for 7SJ60, 7RW60, 7SD6, 7SV60, length 1 m	A
With RS485 connecting cable for SIMEAS Q and SIPROTEC 4, length 1 m	B
With RS485 connecting cable for SIMEAS T, length 1 m	C
Without RS232 connecting cable	A
With RS232 connecting cable 7XV5100-2 for PC/notebook, 9 pin	B
With RS232 adaptor, 25-pin connector (male) to 9-pin connector (female) for PC / notebook	C



7XV5710 USB – RS485 Converter Cable



Fig. 13/65 USB – RS485 converter cable

Function overview

- Compact connector housing
- USB 2.0 / 1.1 interface Type A
- RS485 interface 9-pin SUB-D
- Max. bus length 800 m
- Termination resistances switchable
- Baudrates 300 to 115000 baud
- Indicated data transfer (data LED)
- Protocol transparency (not only for PROFIBUS)
- Power supply via USB connector (no galvanic separation)
- Compatible with 7XV5103 bus system (with gender changer 9-pin female/female)

Description

The USB converter cable with its special pin assignment allows temporary connection of up to 31 Siemens protection devices having an electrical RS 485 interface to a PC with a USB interface for direct or central control with DIGSI 4.

The converter is connected directly to the PC via a standard USB connector (type A). The RS485 connector (9-pin SUB-D male) may be used for direct connection to SIPROTEC 4 devices with RS485 interface modules. To connect individual compact devices with an RS485 interface on terminals, e.g. 7SJ600, 7SD600, 7RW600, etc., the 7XV5103-2AA00 or -3AA00 adapter is required. Using the gender changer (female-female), which is included, the converter may also be connected to the 7XV5103 bus system, which enables communication with all the devices connected to the bus. Because the cable includes a switchable bus termination, it may be connected at either end or in the middle of the bus. The converter draws all the power it needs via the USB interface of the PC.

Application

Data transfer

Before the converter cable is first used, a USB driver must be installed from the CD supplied. The driver creates a new virtual COM port, which may then be selected by the application, e.g. DIGSI 4. The converter works in half-duplex mode on the master/slave principle.

In the quiescent state, the USB interface is inactive and the RS485 interface is ready to receive. For communication, the PC, acting as the master, transmits its data to the USB interface, which in turn forwards the data from the converter at the RS485 interface to the protection device (slave). Following this, the RS485 interface is switched back to receive. Data coming from the protection is now transmitted in the other direction to the USB interface and PC by the converter. A data LED indicates when data transfer is active.

Connection of the compact devices, e.g. 7SJ600 with terminals (without bus cables 7XV5103)

A shielded twisted pair (STP) cable must be used for the RS485 bus. The conductor cross-section must be suitable for termination with ring lugs or SUB-D connectors. The protection devices are connected to the bus in line (not in star or ring topology). The core ends protruding from the shield should be kept as short as possible.

The shield must be connected to the housing ground at both ends. At the last protection device, a 220-Ω terminating resistor is connected between data cores A and B.

Termination of the RS485 bus

The RS485 bus is a two-wire bus (half duplex) over which up to 32 devices (participants) can exchange their data on the master/slave principle. All devices are connected to the bus in line (not in star or ring topology). At the first and last devices, a 220-Ω bus terminating resistor is connected between pin 3 (A) and pin 8 (B), irrespective of whether this is a master or slave device.

The SIPROTEC protection devices are preferably connected to the bus as a slave behind a master, e.g. 7XV5710 or 7XV5650/51 RS484 converter. In these converters (1st device) the terminating resistor may be implemented by additional pull-up/pull-down resistors via DIL switches (S1, S2). The “low-resistance” pull-up/pull-down resistors are essential in various SIPROTEC bus applications, i.e. the use of other converters may result in problems.

In the protection devices, the terminating resistor must only be activated at the last device on the bus using the jumpers provided for that purpose. If this is not possible in the device, an external terminating resistor, e.g. 7XV5103-5AA00 must be applied behind the last device (see Fig. 13/66).

In this example, the terminating resistors of the converter cable are active (default), the terminating resistors that are available at some of the protection devices remain inactive. The bus is terminated after the last device with the 7XV5103-5AA00 bus terminating connector or an external resistor (220 Ω). If the last protection device has a switchable terminating resistor, this may also be activated to ensure termination.

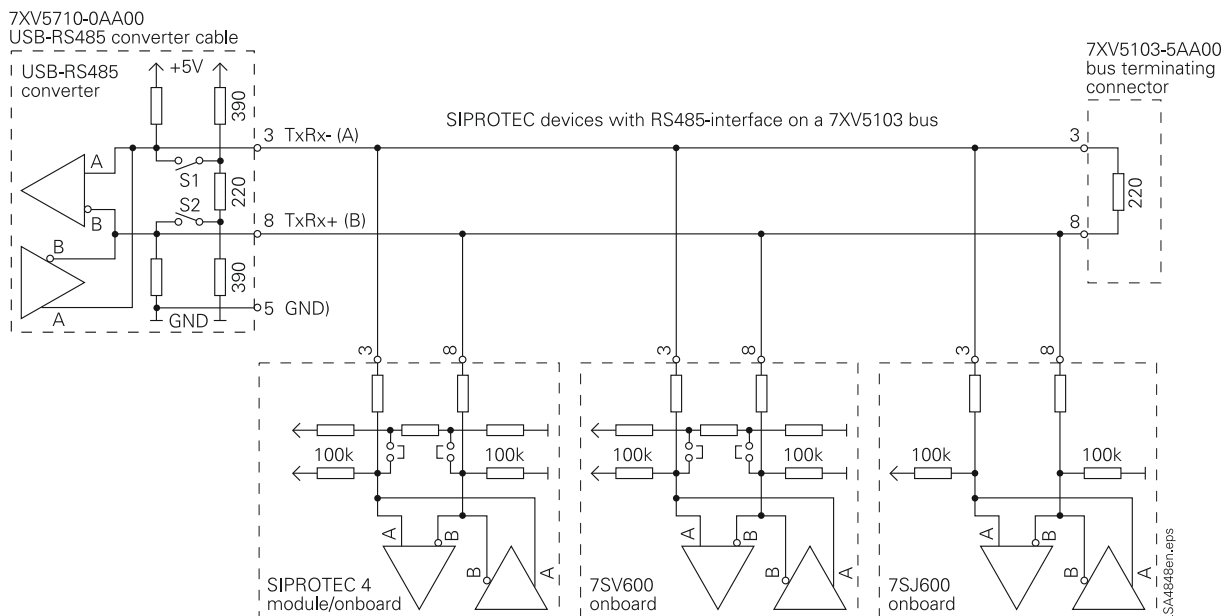

Fig. 13/66
RS485 bus with USB converter cable 7XV5710 and several SIPROTEC devices (connection diagram)

Application

Application example

A number of SIPROTEC 3 and 4 protection devices can be centrally operated via their interface with DIGSI via the 7XV5710 USB converter cable. Suitable cables and adapters are available for the various connection types of the SIPROTEC devices. For more information, please refer to catalog sheet 7XV5103. SIPROTEC 4 devices with an RS485 interface may be directly connected and operated with DIGSI 4.

For the connection of individual compact protection devices with the RS485 interface on terminals e.g. 7SJ600, 7SD600, 7RW600, etc., the adapter cable 7XV5103-2AA00 or the adapter 7XV5103-3AA00 is required (see Fig. 13/67).

The converter cable must only be used on a non-permanent basis because of the lack of galvanic separation. For permanent operation, the FO converters 7XV5652 and 7XV5650/51 should be used. The FO conductor ensures complete galvanic separation between PC and SIPROTEC devices. Corresponding applications may be found at: www.siprotec.com/accessories/7XV56...

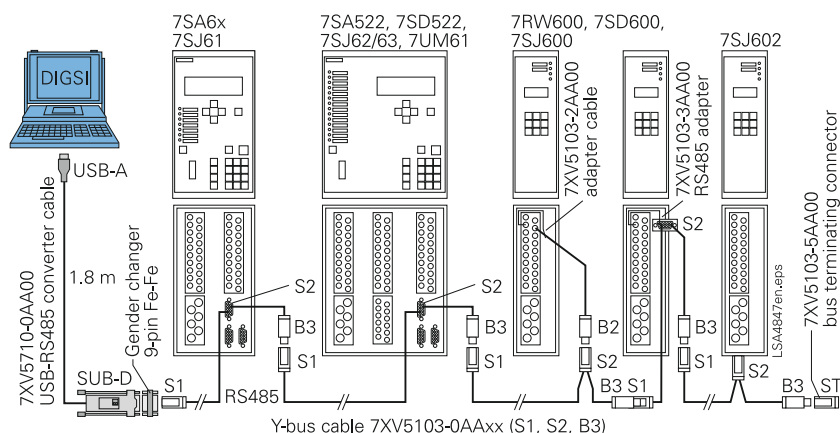

Fig. 13/67 Central operation via the RS485 bus

Technical data

Product	USB converter cable 7XV5710-0AA00	Connection 2 protection	Receiver: +/- 15 kV human body model +/- 6 kV IEC 1000-4-2, contact discharge +/- 12 kV IEC 1000-4-2, air-gap discharge Permitted: up to 128 receivers on the bus True-fail-safe receiver -7 V ... +12 V Common-mode range Thermal protection against output short circuit Driver: +/- 9 kV human body model Slew-rate limited for errorless data transmission -7 V ... +12 V common-mode range Current limiting Thermal shutdown for driver-overload protection
Driver	Included on CD or on the Internet at: www.siprotec.com/accessories/7XV5710	Handshake	None
Installation	Plug & Play	TX/RX switchover	Automatic
Cable length	1.8 m	Serial data transmission channels	Half-duplex 2-wire
USB interface	Virtual COM port	Power supply	+5 V via USB (max. 80 mA) Module logs on with 96 mA at the USB Max. 38 mA ready (converter on, no data transmission) Max. 80 mA full-duplex 4-core operation, (max. data rate)
Connection 1	USB 2.0 (1.1) connector type A	Serial transmission rates	300, 1200, 2400, 4800, 9600, 19200, 38400, 57600, 115200 bits/s
Connection 1 pin assignment	Pin 1 – Vcc Pin 2 – D- Pin 3 – D+ Pin 4 – GND	Status indication	Tx and Rx - 3 mm LED red
Connection 2	SUB-D 9-pin connector (male) with securing screws	Operating temperature	-5 up to +70°C
Connection 2 pin assignment	Pin 3 – Tx/Rx- (A) Pin 5 – GND Pin 8 – Tx/Rx+ (B) All other pins are not connected (nc)	Driver software	Windows 98, Windows 98 SE, Windows 2000, ME, XP, Vista 32/64, Windows 7 32/64. No administrator rights required.
Terminating resistors	Selectable (S1, S2 ON = terminating resistor selected) +5 V – Pin 3 = 390 Ω Pin 3 – Pin 8 = 220 Ω Pin 8 – Pin 5 = 390 Ω	Certification	CE-compliant / RoHS-compliant
		Application	Non-permanent installation with SIPROTEC – devices

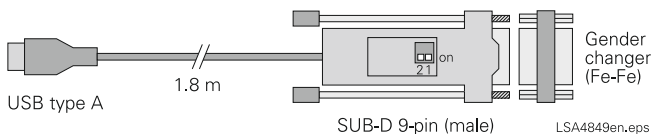

Fig. 13/68 USB converter cable with connector.
Default switch position:
S1+S2 ON = terminating resistor active
Dimensions: 75 x 32 x 15 (l x w x h)

Selection and ordering data

Description	Order No.
USB – RS485 converter cable	7XV5710-0AA00
USB 2.0 /1.1 with connector type A to RS485 with 9-pin SUB-D male connector, pin assignment for SIPROTEC 4 and SIMEAS Q, bus termination switchable, power supply via USB interface, incl. 9-pin female-female gender changer and driver CD For the connection of individual compact protection devices with the RS485 interface on terminals, e.g.. 7SJ600, 7SD600, 7RW600, etc., the 7XV5103-2AA00 adapter cable or the 7XV5103-3AA00 adapter is required	

7XV5820 Industrial Modem and Modem-Router with Switch



Fig. 13/69
Industrial modems

Description

Depending on the available infrastructure and transmission requirements, various modems and routers are available for the remote communication with SIPROTEC protection devices using DIGSI.

The existing infrastructure may consist of analog or digital (ISDN) transmission networks, which may be private (internal telephone system) or a leased line. This may determine the corresponding combinations of the modems or routers. A suitable combination usually consists of a desktop device with plug adapter in the office, and a rail-mounted device in the substation (see Application). The rail-mounted devices may be operated with an optional wide-range power supply adapter with all alternating current networks as well as station batteries.

The desktop analog modem “Pocket 56k” as the office device and the rail-mounted “Modem 56k” in the substation ensure a secure serial data communication with SIPROTEC 3 devices using 8E1 (with parity bit) up to 19.2 kbit/s, or with SIPROTEC devices using 8N1 up to 57.6 kbit/s.

With the same analog modem “Pocket 56k” in the office it is possible to establish a connection to SIPROTEC 4 devices with EN100 interfaces in a local Ethernet network using the rail-mounted modem router “MoRoS Modem 56k” in the substation.

Using the digital modem “Pocket ISDN” as a desktop device in the office and the “ISDN TA” as a rail-mounted device in the substation ensures secure serial data communication with SIPROTEC 3 devices using 8E1 (with parity bit) up to 19.2 kbit/s, or with SIPROTEC 4 devices using 8N1 up to 57.6 kbit/s.

With the same digital modem “Pocket ISDN” in the office, it is also possible to communicate with SIPROTEC 4 devices with an EN100 interface module in a local Ethernet network using a rail-mounted ISDN router “MoRoS ISDN” in the substation.

Other combinations, especially with devices from other manufacturers are strictly not recommended.

All versions are suitable for application in control systems, and substations as well as in areas of energy supply and distribution. The modems can be deployed internationally (certificates of approval see “Technical Data”). As a rule, no certification is required for use in internal networks.

Application

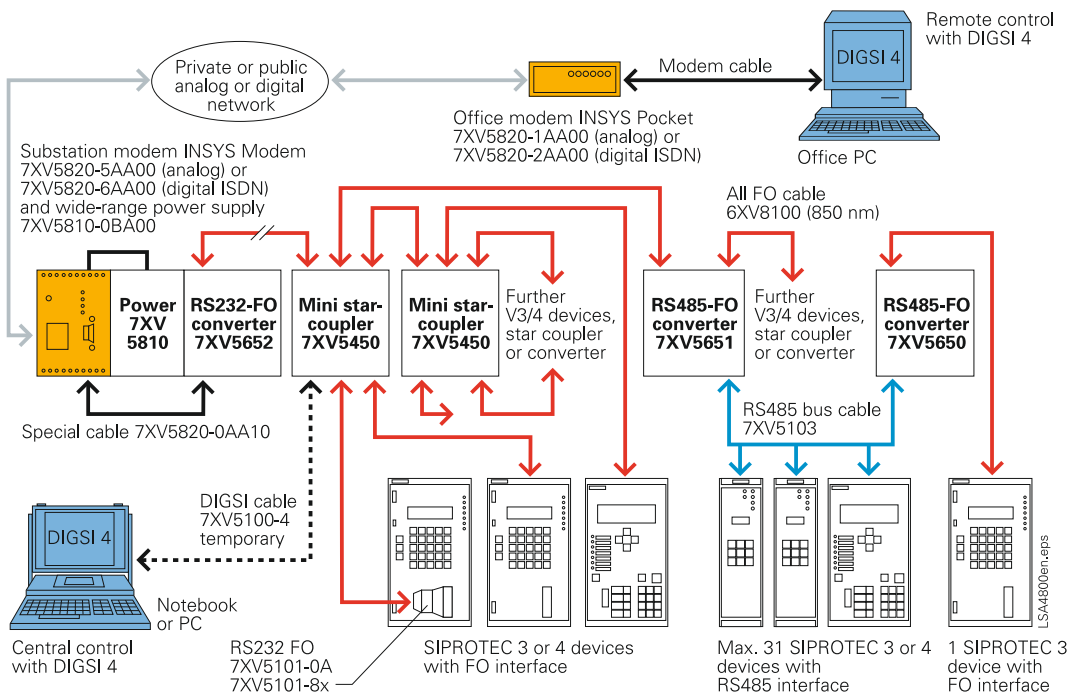

Fig. 13/70 Remote control of SIPROTEC 3 and 4 devices over INSYS Pocket to INSYS Modem, mini star-coupler or RS485 bus with DIGSI 4

Example 1: Remote operation of SIPROTEC 3 devices via modem

This application example illustrates remote operation of SIPROTEC 3 protection devices with an optical interface and compact protection devices with an RS485 interface using analog modems (7XV5820-1 and -5) or digital ISDN modems (7XV5820-2 and -6). Connection to protection or bay control RTUs via an optical interface is achieved with a star configuration using cascable star couplers. The compact protection devices with RS485 interface are connected via a FO-RS485 converter and the RS485 bus system 7XV5103. SIPROTEC 4 devices may be connected optically or electrically, depending on the available service interface.

To ensure secure lightning protection, galvanic separation between the substation modem and the protection devices must be implemented by means of an optical barrier. The substation modem with the 7XV5652 RS232-FO converter is preferably located in a communication or control room while the 7XV5450 star coupler or 7XV5650/51 FO-RS485 converter is located in the first protection cubicle. If the protection devices are to be controlled centrally in the substation using a notebook, this is achieved by plugging a DIGSI cable into the first star coupler, which disables the optical interface and enables the RS232 connection.

Communication with the modems is transparent. Secure data transfer to the SIPROTEC 3 devices is achieved with the data format 8E1 (with parity bit). The data transmission rate depends on the slowest device (9.6 kbit/s or 19.2 kbit/s) and must be set to be equal for all devices. The SIPROTEC 4 devices can then only be operated with this data rate which is relatively slow for SIPROTEC 4.

Application

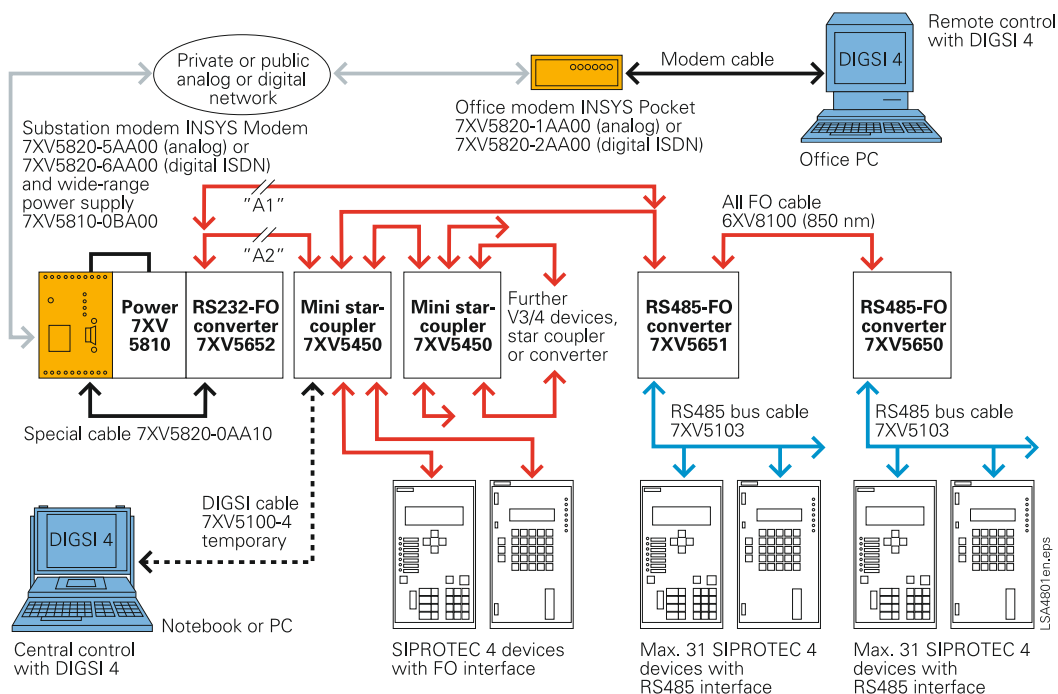

Fig. 13/71 Remote control of SIPROTEC 4 devices over INSYS Pocket to INSYS Modem, mini star-coupler or RS485 bus with DIGSI 4

Example 2: Remote operation of SIPROTEC 4 devices via modem

This application example illustrates remote operation of SIPROTEC 4 devices with an optical or RS485 interface via analog modems (7XV5820-1 and -5) or the very much faster digital ISDN modems (7XV5820-2 and -6). Connection of the protection or RTU devices with optical interface is achieved via cascadable star couplers. The devices with RS485 interfaces are connected via the FO-RS485 converter and the RS485 bus system 7XV5103.

To ensure secure lightning protection of the RS485 bus, galvanic separation should always be implemented between the substation modem and the protection devices by means of an optical barrier. The substation modem with the RS232-FO converter 7XV5652 is preferably located in a communication or control room while the first FO-RS485 converter 7XV5651/50 is located in the first protection cubicle ("A1").

If the protection devices are to be centrally controlled in the substation, an additional star coupler must be used ("A2"). By plugging the DIGSI cable into the first star coupler, the optical interface is disabled and the RS232 connection is established. If no mini star coupler is used, central operation is only possible via the electrical interface of the RS232-FO converter. The modem plug must be disconnected for this purpose.

A secure communication via the modems is possible with the standard data format 8N1, with data compression and error correction. The data transmission rate is determined by the slowest device (38.4 kbit/s or 57.6 kbit/s) and must be set to be the same on all devices.

Application

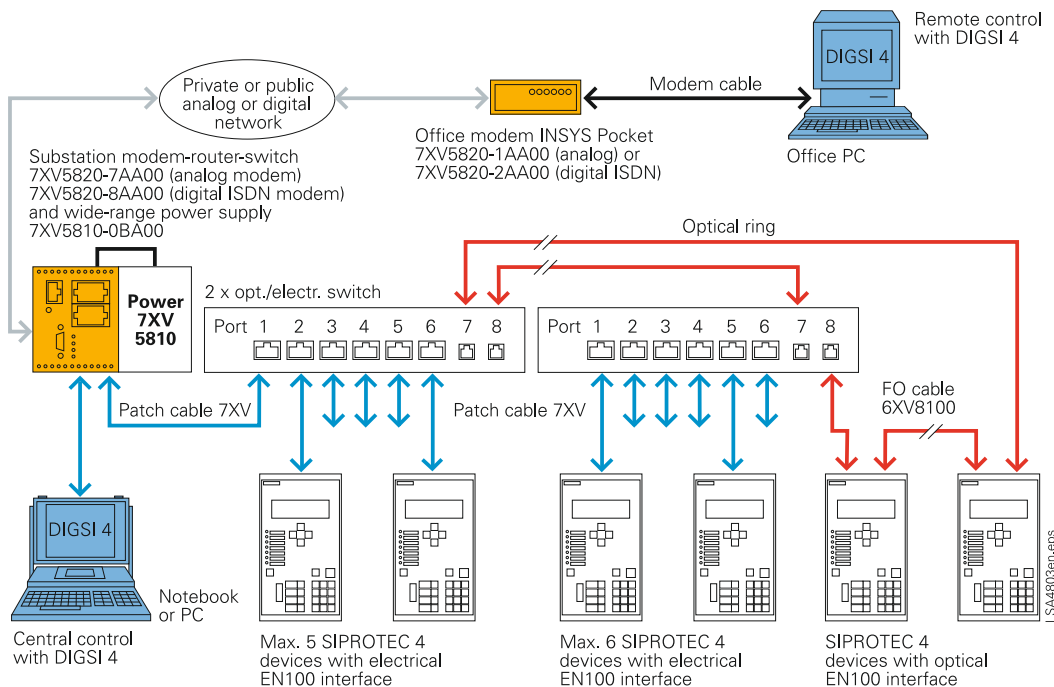

Fig. 13/72 Remote control of SIPROTEC 4 devices with EN100 Ethernet module with DIGSI 4 over INSYS Pocket Modem/ISDN to INSYS Modem/ISDN router with switch and external optical/electrical Switch

Example 3: Remote operation of SIPROTEC 4 devices with Ethernet interfaces via a modem-router

This application example shows remote operation of SIPROTEC 4 protection devices with an optical or electrical EN100 Ethernet interface via an analog or digital ISDN office modem, (7XV5820-1 or -2), to a modem or digital ISDN router (7XV5820-7 and -8). This router with an integrated 4-way switch together with the RUGGETCOM switches connected via a patch cable form a local subnet.

The protection or RTU devices with optical EN100 interface are connected to the RUGGETCOM switches in a ring structure. The protection / RTU devices with an electrical EN100 interface are directly connected to the modem-router and switch or to the electrical interfaces of the RUGGETCOM switches by means of double-shielded patch cables. To minimize any possible interference, the electrical connections with patch cables should be kept as short as possible.

Remote connection from the office to the substation is established by means of a password-protected DUN connection under Windows. The connection is then "transparent" and the protection devices can be operated with DIGSI 4 in the local subnet with their own IP addresses.

If the protection devices are to be conveniently centrally controlled using a notebook in the substation, the notebook with an Ethernet interface can be logged into the local subnet with a patch cable.

Secure communication via modems is performed at 57.6 kbit/s, with standard data format 8N1 with data compression and error correction.

7XV5810-1AA00 and 7XV5820-2AA00 INSYS Pocket Modem

Description

Data communication in the private, commercial and industrial applications is becoming ever more important.

INSYS Pocket Modem 56k and INSYS Pocket ISDN TA fascinate with their sophisticated engineering and their shapely compact metal housing.

The devices are ideal as remote stations for our DIN rail series.



Fig. 13/73 7XV5810/7XV5820 pocket modem

Technical Data

Modem	7XV5820-1AA00	7XV5820-2AA00
Network interface, line requirement	Analog telephone network	ISDN net, S0/I.430 Euro ISDN DSS1
Data transmission rate	Up to 56 kbits/s	64 kbit/s
Software update	Flash	Flash
Approvals	R & TTE, CTR21	R & TTE, CTR3
Application	For international use	Europe
Standards	Developed according to CE directives, manufactured according to ISO 9002	Developed according to CE directives, manufactured according to ISO 9002
Features		
Configuration	Remote configuration, AT commands	Local, via PC terminal, remote via ISDN
Connection	Auto answer mode, hardware-handshake Speed adjustable, sleep mode, auto-bauding, display caller ID	Auto answer mode with optional phone number verification
Data format	10 and 11 bit: 7E1, 7O1, 7N2, 7E2, 7O2, 8N1, 8E1, 8O1, 8N2	B channel: V.110, X.75, V.120, X.25/X.31, HDLC (PPP), T70NL, T90NL D channel: ITR6 DSS1, VNx
Protocols	V.92, V.90, V.34+, V.34, V.32bis, V.32, V.23, V.22bis, V.22, V.21, Bell Norm 103/212, Fax class 1/2	–
Compression	MNP5, V.42 bis, MNP 10, 10 EC, V.44	–
Error correction	MNP 2/3/4 and V.42	–
Security functions	Security call-back, alarm transmission, SMS to fixed network or as fax over AT command, selective call answer, line-in-use detection, selectable key-abort	Access protection via approved phone number (accessible), password protection of remote configuration
Electrical features		
Power supply	9 ... 10 V DC (with plug power supply 230 V AC)	5 V DC (with plug power supply 100 to 230 V AC)
Consumption	Approx. 140 mA DC	Max. 100 mA at 5 V/500 mW
Interface to application	RS232, 9-pin SUB-D jack	RS232, 9-pin SUB-D jack
Interface to network	RJ-12 (Western)	RJ-45 connector
Physical features		
Size in mm (w x d x h)	71 x 128 x 22	71 x 128 x 22
Temperature range	0 to 55 °C	0 to 55 °C
Humidity	0 to 95 % (non-condensing)	0 to 95 % (non-condensing)



Fig. 13/74 7XV5820 modem

7XV5820 INSYS Modem 56k Profi 7XV5820 INSYS ISDN TA Profi

Description

With the INSYS Modem 56k Profi any application can be connected to the analog telephone network, which is available worldwide. The INSYS ISDN 4.0 can easily be connected to the digital ISDN network.

Both modems enhance pure data communication with alarming and security functions: alarms with a user-defined text as an SMS, fax or e-mail are triggered by digital inputs. Data connections (INSYS Modem 56k) and remote control are protected by passwords. The INSYS 56k modem establishes a connection only to a predefined number in response to an incoming call if the security call-back is activated. Selective call answer allows only data calls from specified numbers.

The digital outputs can be controlled remotely. The INSYS 56k modem controls these outputs by data connection as well as by DTMF tones from a tone dial phone. The digital outputs can be configured to display the connections status.

Technical data

Modem	7XV5820-5AA00	7XV5820-6AA00
Network interface	2-wire leased or dial-up line	S0/1.430 Euro ISDN network, DSS1
Data transmission rate	Max. 56 kbit/s	Max. 68 kbit/s (channel building 128 kbit/s)
Digital in-/outputs	2 alarm inputs/2 control outputs	
Watchdog	Yes	–
Software update	–	Flash update
Approvals	–	R & TTE, CTR3
Application	–	Europe
Standards	–	Developed according to CE directives
Features		
Configuration	AT commands via serial line, remote configuration	AT commands, configuration over serial line, remote configuration, CAPI
Connection	Auto-answer mode, idle connection ctrl, auto-bauding, number storage, hard-/software handshake International settings, caller ID presentation, SMS to fixed-line telephone network, fixed serial speed, sleep mode	
Alarm functions	Triggered by alarm input or AT command: send SMS, (send fax and collective fax message 7XV5820-5AA00), establish data connection, transmit message over data connection	
Output control	AT command (local & remote) DTMF	AT command, configurator, connection status
Security functions	Password protection for connection, remote control and security callback Selective call answer, watchdog	
Data formats	10 and 11 bit: 7E1, 7O1, 7N2, 7E2, 7O2, 8N1, 8E1, 8O1, 8N2 Bit transparent	
Protocols, error correction, compression	V.32bis, V.32, V.23, V.22, V.22bis, V.21, V.34+, V.90, V.92, Bell Norm 103/212, Fax Class ½, MNP 2/3/4, V.42, MNP 10, MNP 10 EC, MNP 5 V.42bis	B channel: X.75, X.25/X.31, HDLC/PPP, V.110, V.120 asynchronous; D channel: X.31
Electrical features		
Supply voltage	10 to 60 V DC	10 to 60 V DC
Current consumption	Transmission: 200 mA (at 12 V) Standby: 160 mA (at 12 V)	40 mA
Inputs/outputs	SPDT (single-pole double-throw) switches by galvanically isolated relays, max. voltage 30 V DC/42 V AC, max. current: 1 A DC/0.5 A AC	
Serial line speed	300 bit/s to 115.2 kbit/s	1.2 to 230.4 kbit/s
Physical features		
Housing size	55 x 110 x 75 (w x d x h) in mm	
Ambient temperature	0 to 55 °C	0 to 70 °C
Humidity	0 to 95 % (non-condensing)	0 to 90 % (non-condensing)

7XV5820-7/-8AA00 Modem-Router-Switch (MoRoS)

Description

Modem-Router-Switch by INSYS combines a modem, a router and a 4-port switch. The dial-in and dial-out functionality enables remote maintenance and operation of devices in an Ethernet network.

The MoRoS device is available with an integrated analog modem or with ISDN-TA. The integrated 4-port switch allows for direct connection of up to four network devices. The MoRoS device has an international 56k modem for global application. The configuration of the MoRoS device is easy and fast via a web interface.

MoRoS by INSYS is a device that combines modem, router and switch functions for the remote maintenance of Ethernet-enabled products, e.g. PLC, HMI, etc.

Function overview

- Integrated communication module (analog modem or ISDN-TA)
- Dial-in
- Dial-out (dial-on-demand)
- 4-port switch with 10/100 Mbits/s
- DHCP server and client
- Integrated configuration interface with help function
- Authentication for up to 10 users (dial-in)
- Dialing filter for dial-out
- Authentication via PAP, CHAP, MS-CHAP, MS-CHAP 2
- Easy configuration
- Local or remote configuration
- Firmware update (local and remote)
- 2 digital inputs and outputs
- Buffered RTC (real time clock)
- Full NAT
- DNS relay
- Serial Ethernet Server ¹⁾
- VPN ¹⁾
- Firewall ¹⁾

¹⁾ version MoRoS PRO only

Technical data

Modem	7XV5820-7/-8AA00 MoRoS
Certifications	R & TTE, CTR2 (dial-up line), CTR3 (ISDN), CE
Dial-up line	Transmission rate 56 kbits/s
ISDN	Transmission rate 64 kbits/s
Configuration	Web interface, AT command (via web interface), local and remote



Fig. 13/75 7XV5820 Modem-Router-Switch (MoRoS)

Router

Function	Dial-in, dial-out
Authentication	10 users for dial-in, authentication via PAP, CHAP, MS-CHAP, MS-CHAP 2
Dialing filter (dial-out)	Filtering of IP addresses and/or ports
Configuration	Web interface, AT command (via web interface), local and remote
DHCP server and client	
Watchdog (ext. hardware watchdog)	
RTC (buffered real time clock)	
Full NAT	
VPN ¹⁾	
Firewall ¹⁾	
Serial Ethernet server ¹⁾	

Switch

Ports	4
Operating mode	10/100 Mbits/s for full and half duplex operation
Auto detect	Automatically recognizes patch and cross-over cables; automatic speed adjustment

Configuration

Web interface	Local/remote
Additional features	Digital inputs and outputs, firmware update local/remote

Supply

Voltage	10 V to 60 V DC
Power input	Approx. 2.5 W (during connection)

Physical features

Housing size	70 x 110 x 75 mm
Operating temperature	0 to 55 °C
Humidity	0 to 95 % (non-condensing)
Weight	10.58 oz

Selection and ordering data

Description	Order No.
<i>7XV5820 modem/modem-router</i>	<i>7XV5820-□AA00</i>
<i>Analog Pocket Modem 56k</i> Desktop device, with plug-in power supply 230 V AC	1
<i>Digital Pocket Modem ISDN 64k</i> Desktop device, with plug-in power supply 100 to 230 V AC	2
<i>Analog Modem 56k</i> for DIN rail-mounting, power supply 10 to 60 V DC	5
<i>Digital Modem ISDN 64k</i> for DIN rail-mounting, power supply 10 to 60 V DC	6
<i>Analog Modem-Router</i> with 4-way switch for DIN rail-mounting, power supply 10 to 60 V DC	7
<i>Digital ISDN Router</i> with 4-way switch for rail-mounting 10 to 60 V DC	8
<i>Modem/Modem-Router Accessories</i>	<i>7XV5820-0AA10</i>
Data cable from modem to 7XV5300, 7XV5450, 7XV5550, 7XV5652 2 x SUB-D connector, 9-pin female, length 2 m	

7XV5850 Ethernet Modems for Office Applications



Fig. 13/76
7XV5850 Ethernet modem

Function overview

- DIGSI supports the administration and the setting-up of connections via the Ethernet network.
- RS232 interfaces for data transfer and configuration of the modem.
- Serial baud rate and data format (RS232) for the terminal devices is selectable from 2400 Bd up to 57.6 kBd with data format 8N1, 8E1.
- An Ethernet interface LAN to the 10/100 Mbit network.
- Better security with password protection and IP address selection is possible.

Description

A control PC and protection units can exchange serial data via an Ethernet network using two Ethernet modems 7XV5850 and 7XV5655. Connection to the Ethernet modem is in each case made via the asynchronous serial interface of the terminal units. In the modem, the serial data is packed into the secure IP protocol as information data, and is transferred between the modems using the Ethernet connection. Conformity with the standard and gap-free transmission of serial DIGSI or IEC 60870-5-103/101 telegrams via the network is ensured by the modem which receives the serial telegram communication and packs the serial IEC telegrams into blocks for communication via the Ethernet. The data is transmitted in full duplex mode; serial control wires are not supported. Connection is established between the IP address of the dialing modem in the office and the IP address of the pick-up modem in the substation, and is configured prior to dialing up with DIGSI by means of AT commands via the RS232 interface.

The substation modem may be configured to have password protection, and provides the additional security feature, whereby access is only permitted from defined IP addresses, e.g. only that of the office modem. The modem is accessed with DIGSI Remote like a normal telephone modem with the exception that instead of telephone numbers, IP addresses are assigned by the network administrator for each modem.

Application

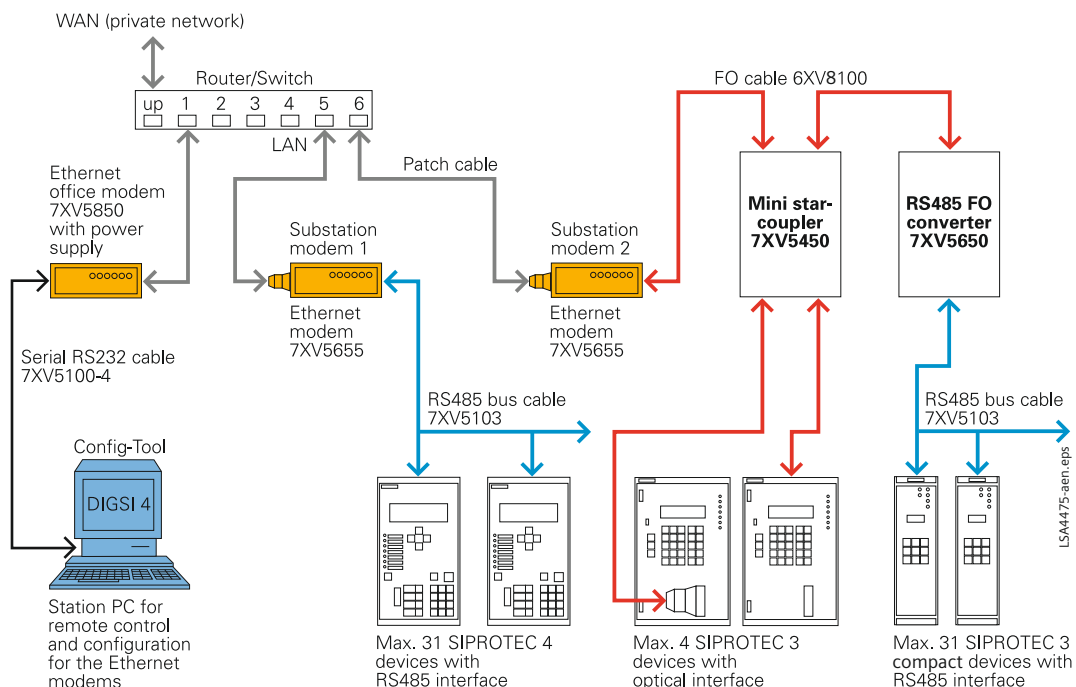

Fig. 13/77 Operation of various SIPROTEC protection unit generations via Ethernet modems

Using the office computer and DIGSI 4, both substation 1 and 2 may be dialed up via Ethernet modems. A TCP/IP point-to-point data connection is established between the office modem and corresponding substation modem when dialed up via the network. This is maintained until the office modem terminates the connection. The serial data exchange takes place via this data connection, with the modem converting the data from serial to Ethernet with full duplex mode. Between the office modem and the office PC, the highest baud rate is always used, e.g. 57.6 kB for SIPROTEC 4 units. The serial baud rate of the substation modem is adapted to the baud rate required by the protection relays, e.g. substation modem 1 with 57.6 kB for SIPROTEC 4 and substation modem 2 with 9.6 kB for SIPROTEC 3 units. These settings are only defined once in the modem. The Ethernet modems are integrated in DIGSI 4 similar to telephone modems. Instead of the telephone number, the preset IP address assigned to the modem is selected.

If later an Ethernet connection is available in the substation, the existing modem can be replaced by an Ethernet modem. The entire serial bus structure and cabling may remain unchanged.

Technical data

Connections

RS232 interface 9-pin, SUB-D connector
 Ethernet 10BaseT, 10/100 Mbit, RJ45
 Power supply (see below)

Desktop device for office use 7XV5850-0AA00

Housing Desktop housing, plastic, charcoal grey, 46 x 109 x 74 (W x H x D) in mm
 Supply Wide-range plug-in power supply, auxiliary voltage 100 – 240 V AC
 Scope of supply With RS232 cable for Notebook/PC. With Ethernet cable (cross-over) 2 m

Indication (8 x LED)

Power	Operating voltage o.k.
RS232 TxD	Transmitting data to RS232
LAN Tx	Transmitting data to LAN
Error	Error on RS232
System	RS232 connection established
RS232 RxD	Receiving data from RS232
LAN Rx	Receiving data from LAN
Link LAN	LAN connection established

Selection and ordering data

Description	Order No.
<i>Ethernet Modem</i>	<i>7XV5850-0AA00</i>

Ethernet modem for serial, asynchronous transmission of data up to 57.6 kbit via the 10/100 Mbit Ethernet and configuration software

Desktop device (office version)

Connection to Ethernet via RJ45 connector, serial connection SUB-D 9-pin socket including wide-range power supply 100/240 V AC

With cross-over Ethernet patch cable 2 m for configuration

With serial connection cable to PC 2 m

Accessories for Communication

6XV8100 F.O. Cable

Selection and ordering data

Description	Order No.
<i>F.O. cable for indoor application with FSMA or ST connectors</i>	<i>6XV8100-0DA□ 1-0A□□¹⁾</i>
Plastic F.O. link cable W/2 Fibers for links inside a cubicle, fiber type PMMA S980/1000PE-insulation diam. = 2.2 mm black good resistance to oil, petrol, acid and leach, cable for simple systems of loads, base material L46916-U2-U19, V-2x 1S980/1000PE	
<i>Connector</i>	
Not used	
Not used	
Both sides with FSMA connectors prefabricated	2
Not used	
Both sides with ST connectors prefabricated	4
Not used	
<i>F.O. duplex cable for indoor and outdoor application with FSMA, LC or ST connectors</i>	<i>6XV8100-0BD□ 1-□□□□¹⁾</i>
Fiber-optic duplex data line for in- and outdoors, 2 break-out elements fiber type glas 62.5/125 μm, halogen-free and flame-retardant, non-metallic rodent prot. external diam. = 8.3 mm, black; internal diam. = 1.8 mm, orange; base material L46900-G2-J1, AT-VHBH 2G62.5/125 3.2B200/0.9F500	
<i>Connector</i>	
None	0
One side with FSMA connectors	1
Both sides with FSMA connectors	2
One side ST, other side LC connectors	3
Both sides with ST connectors	4
One side FSMA, other side ST connectors	5
Both sides with LC connectors	6
<i>F.O. duplex cables for indoor application with FSMA, LC or ST connectors</i>	<i>6XV8100-0BE□□-□□□□¹⁾</i>
Fiber-optic duplex data line for indoors, 2 break-out elements fiber type glas 62.5/125 μm, halogen-free and flame-retardant, internal diam. = 1.7 mm, orange; external diam. = 2.8 x 4.5 mm, orange; base material I-VHH 2 x 1 x G62.5/125	
<i>Connector</i>	
Without	0 1
One side with FSMA connectors	1 1
Both sides with LC connectors	1 4
One side ST, other side LC connectors	1 7
Both sides with FSMA connectors	2 1
Both sides with ST connectors	4 1
One side FSMA, other side ST connectors	5 1

1) For complete Order No. visit www.siemens.com/siprotec

Accessories for Communication

6XV8100 F.O. Cable

Selection and ordering data

Description	Order No.
<i>F.O. duplex cables for indoor and outdoor application with MTRJ and ST connectors</i>	<i>6XV8100-0BF□ 1 - □ □ A □ 1)</i>
Fiber-optic duplex data line for in- and outdoors, 2 break-out elements fiber type glas 62.5/125 μm, halogen-free and flame-retardant, non-metallic rodent prot. external diam. = 8.3 mm, black; internal diam. = 1.8 mm, orange; base material AT-VHBH 2G62.5/125	
<i>Connector</i>	
One side with MTRJ connector, other side prepared for ST connector	2
Both sides with MTRJ connector	3
<i>F.O. duplex cables for indoor application with MTRJ and ST connectors</i>	<i>6XV8100-0BG□ 1 - □ □ □ 0 1)</i>
Fiber-optic duplex data line for indoors, 2 break-out elements fiber type glas 62.5/125UM, halogen-free and flame-retardant internal diam. = 1.7 mm, orange; external diam. = 2.8 x 4.4 mm, orange; base material I-VHH 2 x 1 x G62.5/125	
<i>Connector</i>	
One side with MTRJ connector, other side prepared for ST connector	2
Both sides with MTRJ connector	3

7KE600 Ethernet Patch Cable

Selection and ordering data

Description	Order No.
<i>Ethernet patch cable with double shield (SFTP) LAN connector on both sides</i>	<i>7KE6000-8GD0□ - □ AA □</i>
SIMEAS R <----> HUB HUB <----> PC	
Length 0.5 m	0 0 5
Length 1.0 m	0 1 0
Length 2.0 m	0 2 0
Length 3.0 m	0 3 0
Length 5.0 m	0 5 0
Length 10.0 m	1 0 0
Length 15.0 m	1 5 0
Length 20.0 m	2 0 0
<i>Ethernet patch cable, cross-over connection with double shield (SFTP) LAN connector on both sides</i>	<i>7KE6000-8GE0□ - □ AA □</i>
HUB <----> HUB SIMEAS R <----> PC	
Length 0.5 m	0 0 5
Length 1.0 m	0 1 0
Length 2.0 m	0 2 0
Length 3.0 m	0 3 0
Length 5.0 m	0 5 0
Length 10.0 m	1 0 0
Length 15.0 m	1 5 0
Length 20.0 m	2 0 0

1) For complete Order No. visit www.siemens.com/siprotec