

# SIEMENS

## Mini-Starcoupler 7XV5450-0xA00

### Operating Instructions

---



Oct. 2006

## Table of content

<b>1</b>	<b>GENERAL INSTRUCTIONS .....</b>	<b>3</b>
1.1	Qualified Personnel .....	4
1.2	Safety Notes .....	5
1.3	Intended Use .....	6
1.4	Explanation of the symbols at the device: .....	6
1.5	Exclusion of liability .....	7
1.6	Copyright .....	7
<b>2</b>	<b>1 OPERATING INSTRUCTIONS .....</b>	<b>8</b>
2.1	1.1 Scope of Application .....	8
2.2	Technical Features .....	8
2.3	General Data .....	8
2.4	Data Transfer .....	9
2.5	Connection to a PC with Serial Interface .....	10
2.6	FO-Connections .....	10
<b>3</b>	<b>TECHNICAL DATAS .....</b>	<b>11</b>
3.1	Hardware features .....	11
3.2	Safety Tests .....	12
3.3	Dielectric Tests .....	13
3.4	Interference Emission .....	13
3.5	Interference immunity .....	14
3.6	Climatic Stress tests .....	15
3.7	Mechanical Stress Tests .....	16
3.8	Dimension Drawings .....	17
3.9	Ordering Data .....	17
<b>4</b>	<b>DESCRIPTION OF THE FUNCTIONAL UNIT .....</b>	<b>18</b>
4.1	Terminal Assignment .....	18
4.2	Screw-type terminals X2, X7 .....	19
4.3	RS232-Connector X1 .....	19
4.4	FO-Connections .....	20
4.5	Switch positions .....	20
	Assignment Switch 1 .....	21
<b>5</b>	<b>INSTALLATION AND COMMISSIONING .....</b>	<b>22</b>
5.1	Reference to Installation .....	22
5.2	Connection .....	22
5.2.1	Power supply X2 .....	23
5.2.2	Alarm relay terminals X7 .....	23
5.2.3	Fibre Optic (FO) connections Rx, Tx .....	23
5.3	Commissioning .....	24
5.4	Maintenance .....	24
<b>6</b>	<b>APPLICATION EXAMPLES .....</b>	<b>25</b>
6.1	Optical star configuration .....	25
6.2	Optical ring configuration .....	26

## **1 General Instructions**

This manual includes the information required for the normal use of the products described therein. It is intended for technically qualified personnel which has been specially trained or has special knowledge in the fields of protection-, instrumentation-, control-, and automatic control engineering (called automation in the following).

The knowledge and the technically correct translation of the safety instructions and warnings included in this manual are a prerequisite for the safe installation and commissioning, as well as for safety during operation and maintenance, of the product described. Only qualified personnel, as defined in the following explanation, possess the technical knowledge required to interpret correctly and to put into action for each individual case the safety instructions and warnings given in this document in a general manner.

This manual is an integral part of the scope of delivery. However, it cannot take into account every detail on all types of the described product and also every possible case regarding installation, operation or maintenance. If further information is desired or in case special problems should arise, which are not treated adequately in this document, it is possible to obtain additional details from the local Siemens office or from the addresses stated in the back of this manual.

Additionally, we point out that the content of this product documentation is not part of or modifies any previous or existing agreement, promise, or legal relationship.

All obligations by Siemens result from the respective purchase order which also includes the complete and exclusively valid warranty provision. The contractual warranty regulations are neither extended nor limited by the statements in this document.

## 1.1 Qualified Personnel

Tampering with the device/system or noncompliance with the safety notices given in this manual may cause severe bodily injury or property damage. Therefore any interventions on the device/system may only be performed by adequately qualified personnel.

Qualified personnel as per the safety notices given in these instructions or on the product itself is:

- personnel involved in planning and configuration activities and familiar with the safety concepts used in automation engineering;
- operating personnel trained for working with automation systems and familiar with the content of this manual as far as it deals with operational aspects;
- commissioning and service personnel having adequate training and qualification to repair this type of automation equipment and/or having authorization to commission, release, ground and tag devices, systems and electrical circuits.

## 1.2 Safety Notes

These operating instructions contain notes that are to be complied with for your personal safety as well as to avoid property damages. These notes are marked by a triangular warning symbol and the different degrees of danger are categorized as follows:



### **Danger**

Disregard of the corresponding precautionary measures will cause death, severe bodily injury or considerable property damage.



### **Warning**

Disregard of the corresponding precautionary measures may cause death, severe bodily injury or considerable property damage.



### **Attention**

Disregard of the corresponding precautionary measures may lead to slight bodily injury or minor property damage.



### **Note**

Shall draw your attention to special information on the product, product handling or the corresponding section of the documentation.



### **Qualified personnel**

Commissioning and operation of the equipment is to be performed by qualified personnel only. In the context of safety notes in this manual, the term qualified personnel refers to persons authorized to perform commissioning, grounding and labelling of devices, systems and electrical circuits.

## 1.3 Intended Use

Please observe the following



### **Warning**

The device must be operated only within the scope of its intended use according to these operating instructions and in connection with third-party equipment or compounds recommended or accepted by Siemens.

Faultless and safe operation of the product require proper transport, storage, mounting and installation as well as careful operation and maintenance.

## 1.4 Explanation of the symbols at the device:



### **Danger**

Warning of a danger.

Please read the documentation.

To be operated only by qualified personnel.



Double insulation

## **1.5 Exclusion of liability**

The contents of this document have been reviewed on their compliance with the hardware and software described therein. Yet, deviations cannot be excluded, so that we cannot guarantee full compliance. The specifications in this document are, however, reviewed at regular intervals. Necessary corrections will be included in the next edition. You are invited to send us your suggestions for improvement.

## **1.6 Copyright**

Copyright Siemens AG 2000. All rights reserved.

Transmission or reproduction of this document, as well as the use and forwarding of its contents is not permitted without express written authority. Offenders will be liable for damages. All rights, including rights created by patent grant or registration of a utility model or design, are reserved.

Subject to technical changes without notice.

## 2 1 Operating Instructions

### 2.1 1.1 Scope of Application

The Mini Star Coupler is used for optical connection of up to four terminal units with an optical interface in a star topology to a master unit for centralized operation, thus allowing to establish an interference-immune connection between the field devices and the centralized operating unit. Direct communication between a PC and the terminal units is possible via the integrated RS232 interface.

### 2.2 Technical Features

The optical mini star coupler distributes the messages to all terminal units via up to 4 optical interfaces. The number of terminal units can be increased by a cascade connection. The transmitter output of the mini star coupler is connected to the receiver input of the appropriate terminal unit. As the messages contain an address, only the addressed terminal unit responds. The terminal unit then answers to the PC via the mini star coupler's receiving and transmitting interface. It is thus possible to optically connect up to four terminal units to a central unit. Cascading of the mini star coupler is possible.

- All optical inputs and outputs (full duplex) have ST-BOFC connectors and can be set individually to Light ON or Light OFF in idle state.
- Data transmission is transparent, i.e. protocol-independent.
- The wavelength of all optical inputs and outputs is 820 nm.
- The typical distance to the system interfaces of the protection devices spanned by FO cables is 1.5 km.
- The star coupler has an integrated power supply unit and is lodged in a plastic housing.
- The auxiliary power supply of the star coupler can be operated without switchover in the rated voltage ranges of DC 24 - 250V and AC 60 - 230V.
- LEDs are provided for indication of the operating voltage (green LED) and of data transmission (yellow LEDs).

### 2.3 General Data

The star coupler is equipped with one optical PC input and output and 4 optical inputs and outputs to the terminal units. Cascading of the star



coupler is possible. The Mini-Starcoupler has a plastic housing that can be snapped onto a DIN EN 50022 rail. The auxiliary power supply is fed in via terminals on one side of the housing. Because of its extremely wide auxiliary voltage range (DC 24 - 250 V and AC 60 - 250 V), the Starcoupler can be connected without switchover to all common types of station batteries and AC mains voltage supplies.

The readiness for service of the unit is indicated by means of a potential-free signalling contact (terminals 1,2) that can be used to communicate the following fault conditions to a control center:

- No supply voltage

Failure of internal power supply

When a fault condition is present, the contact is closed.

## **2.4 Data Transfer**

Operation of the mini star coupler is transparent and full-duplex. Data received from the master unit are forwarded by the receiver of channel 1 to all outputs (channels 2, 3, 4 and 5). Data from one of the outputs (channel 2, 3, 4 and 5) are sent to the transmitter of channel 1. The logic of the optical interfaces is positive (Light OFF in idle state), incoming light signals are treated as active = 1 (high). For use in systems operating

with a negative logic, the star coupler can be switched over to negative logic by means of a switch that is accessible from outside. Inversion of the logic applies to both the optical input and the optical output of this interface. On delivery, the star coupler is set to positive logic (Light OFF in idle state). When set to negative logic, the receiver must have light in idle state, otherwise the star coupler is blocked.

**2.5 Connection to a PC with Serial Interface**

For central remote, the serial interface of the star coupler can be connected to a PC by means of a serial cable. Pins 7 and 8 of this cable must be jumpered. (Note that this deactivates FO Input channel 1). The serial interface distributes data to the four FO channels and receives data from these channels.

**Assignment 7XV5100-4**

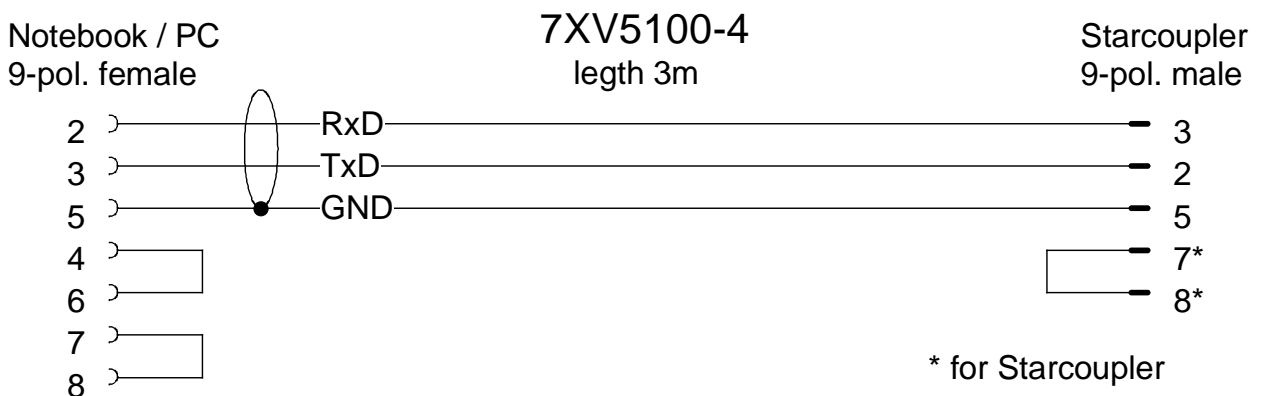

**2.6 FO-Connections**

The receiving optical connectors are marked with Rx, the transmitting connections with Tx.

**ATTENTION!** Please tight the mechanical screw connections of the FO - cables with FSMA plug carefully and only by hand (do not use tools). The ST plugs are to be shifted with the lateral nose into the groove of the device connection and locked afterwards. During the installation of the FO - cables the bending radius specified for the cable is to be kept.

**3 Technical datas**

**3.1 Hardware features**

<p><b>Mechanical design</b>  Housing  Dimensions  Weight  Degree of protection      Housing      Terminals</p>	<p>Plastic, EG90  see dimensional drawings  approx. 250g  according EN60529, IEC60529      IP 51 plastic      IP 20</p>
<p><b>Auxiliary voltage U<sub>H</sub></b>  Rated input voltage  - DC voltage  - AC voltage  Fuse internal   Class of protection (depends on input voltage)  Power consumption  - DC voltage  - AC voltage</p>	<p>24 V - 250 V DC ± 20 %  24 V - 230 V AC ± 20 % / 45-65 Hz  1,25 A slow blow (not exchangeable)   III   With U<sub>H</sub> = U<sub>HN</sub>; typical value  3 W  2.5 W; 3.5 VA</p>
<p><b>Alarm relay</b>  1 Relay   Connector  Test voltage  Switching voltage (nominal value)  Switching capability  Switching current  Fault indicator</p>	<p>MSR-Relay, 1 NC (open) contact, potential free  2-pol. Phönix terminal  3,7 kV<sub>eff</sub>  250 V DC  20 W/VA  1 A permanent  LED green: 5 V o.k,</p>
<p><b>RS232-interface</b>  Connector  Baudrate  Test voltage</p>	<p>9-pol. SUB-D, socket or  9600 - 115200 bauds  2 kV AC towards other connections</p>

<p><b>Optical interfaces</b></p> <p>Optical inputs / outputs</p> <p>Optical connectors</p> <p>Laser class 1 acc. EN60825-1/-2</p> <p>Data flow indication</p> <p>Wave length</p> <p>Launched power</p> <p>Sensitivity</p> <p>Optical budget</p> <p>Maximum distance spanned</p> <p>Baud rates</p>	<p>5 transmitter, 5 receiver</p> <p>Factory setting: Light OFF in idle state</p> <p>BFOC-ST connectors (plastic protective caps)</p> <p>Yellow LED: Transceiving data on Input channel 1</p> <p>820 nm</p> <p>-19dBm with 50/125µm multimode fibre</p> <p>-15dBm with 62,5/125µm multimode fibre</p> <p>-6,2dBm with 200µm HCS fibre</p> <p>-30dBm</p> <p>10dB (+3 dB system budget- safety margin)</p> <p>3.0 km with 62,5/125µm multimode fibre</p> <p>1.5 km in combination with SIPROTEC systems with 62,5/125µm multimode fibre</p> <p>3.5 m with 980/1000 plastic fibre</p> <p>9600 - 115200 Baud</p>
---	---

## 3.2 Safety Tests

<p><b>Safety tests</b></p> <p>according DIN EN 61010 Part1</p> <p>Overvoltage category</p> <p>Degree of pollution</p> <p>Fire resistance classification according to UL 94</p>	<p>III</p> <p>2</p> <p>V0</p>
--	-------------------------------

**3.3 Dielectric Tests**

<p><b>Dielectric tests</b>  EN61010 IEC 255-5:  ANSI/IEEE C37.90.0</p> <p>Voltage test (routine test)  Auxiliary power to fault relay  Auxiliary power to RS232 interface  Fault relay to RS232 interface</p> <p>Surge voltage test (type test)  VDE 0435, Pt. 303  Auxiliary power to relay  Auxiliary power to RS485 interface  Relay to RS485 interface</p>	<p>5,25 kV DC / 1s (with bypass capacitors)  3,7 kV AC / 50Hz / 1s (without bypass capacitors)</p> <p>5 kV (peak); 1,2/50 <math>\mu</math>s; 0,5 J;  3 pos. and 3 neg. surges in intervals of 5 s  all circuits, class III (not on open contacts)</p>
--	---

**3.4 Interference Emission**

<p><b>Interference Emission</b>  Standard: EN 50081-1  Conducted interference, only power supply voltage  IEC CISPR 22, EN55022  VDE 0878 Teil 22</p> <p>Radio interference field strength  IEC CISPR 22, EN55022  VDE 0878 Teil 22</p>	<p>150 kHz to 30 MHz</p> <p>Limit class B  Limit class B</p> <p>30 MHz to 1000 MHz  Limit class B  Limit class B</p>
---	--

## 3.5 Interference immunity

<p><b>Interference immunity</b> IEC 255-22 (product standards) EN 61010-1 (Generic standard)</p>	
<p>High frequency test IEC 60255-22-1, class III VDE 0435 Teil 303, Klasse III</p>	<p>1 MHz; 400 surges per s; dur. 2 s 2,5 kV longit.voltage; 1,0 kV transverse voltage</p>
<p>Electrostatic discharge (ESD) IEC 61000-4-2, class III IEC 60255-22-2 class III EN 61000-4-2, of degree 4</p>	<p>4 kV contact discharge, 8 kV air discharge, both polarities; 150 pF; Ri = 330 Ohm</p>
<p>Irradiation with HF field, non modulated IEC 60255-22-3, Klasse III</p>	<p>10 V/m; 27 MHz to 500 MHz</p>
<p>Irradiation with HF field, amplitude modulated IEC 61000-4-3 ENV 50140, class III EN 61000-4-3</p>	<p>10 V/m; 80 MHz to 1000 MHz; 80% AM; 1kHz</p>
<p>Irradiation with HF field, pulse modulated IEC 61000-4-3 ENV 50140 / ENV50204, class III</p>	<p>10 V/m; 900 MHz; repetition frequency 200 Hz; duty cycle of 50% or duty cycle of 100%</p>
<p>Fast transient disturbance / burst IEC 61000-4-4, class IV  IEC 60255-22-4, class IV  EN 61000-4-4, class IV</p>	<p>On auxiliary voltage inputs 4 kV; 5/50 ns; 5 kHz; burst duration 15 ms Repetition 300 ms; both polarities; Ri = 50 Ohm; Test duration 1 min</p>

<p>Fast transient disturbance / burst IEC 61000-4-4, Klasse III</p> <p>IEC 60255-22-4, Klasse III</p> <p>EN 61000-4-4, Klasse III</p>	<p>On signal lines 2 kV; 5/50 ns; 5 kHz; burst duration 15 ms Repetition 300 ms; both polarities; Ri = 50 Ohm; Test duration 1 min</p>
<p>Line conducted HF, amplitude modulated IEC 61000-4-6, class III EN 61000-4-6, class III</p>	<p>10 V; 150 kHz to 80 MHz; 80% AM; 1 kHz</p>
<p>Immunity to power frequency magnetic field EN 61000-4-8, class IV</p>	<p>30 A/m, permanent; 300 A/m during 3 s; 50 Hz</p>

### 3.6 Climatic Stress tests

<p><b>Ambient Temperatures</b></p>	
<p>Recommended operating temperature</p>	<p>-5°C to +55°C (+23° F to +131°F)</p>
<p>Limiting temporary (transient) operating</p>	<p>-20°C to +70°C (-4° F to +158°F)</p>
<p>Limiting temperature during storage (packing from the factory)</p>	<p>-25°C to +55°C (-13° F to +131°F)</p>
<p>Limiting temperature during transport (packing from factory)</p>	<p>-25°C to +70°C (-13° F to +158°F)</p>
<p>Permissible humidity</p>	<p>mean value per year &lt; 75% relative humidity, 30 days per year 95% rel. humidity, condensation not permissible!</p>

**3.7 Mechanical Stress Tests**

<p><b>Vibration and shock during operation</b></p> <p>Vibration IEC 60255-21-1, class 1 IEC 60068-2-6</p> <p>Shock IEC 60255-21-2, class 1</p> <p>Seismic vibration IEC 60255-21-2, class 1 IEC 60068-3-3</p>	<p>sinusoidal 10 Hz to 60 Hz: ±0,035mm amplitude.; 60Hz - 150 Hz: 0,5g acceleration Frequency sweep rate 10 oktave/min 20 cycles in 3 orthogonal axes,</p> <p>semi-sinusoidal Acceleration 5 g, duration 11 ms, 3 shocks in each direction of 3 orthogonal axes</p> <p>sinusoidal 1 Hz to 8 Hz: +3,5mm amplitude (horizontal axis) 1 Hz to 8 Hz: +1,5mm amplitude (vertical axis) 8 Hz to 35 Hz: 1g acceleration (horizontal axis) 8 Hz to 35 Hz: 0,5g acceleration (vertical axis) Frequency sweep rate 1 octave / min 1 cycle in 3 orthogonal axes</p>
---	--



### 3.8 Dimension Drawings

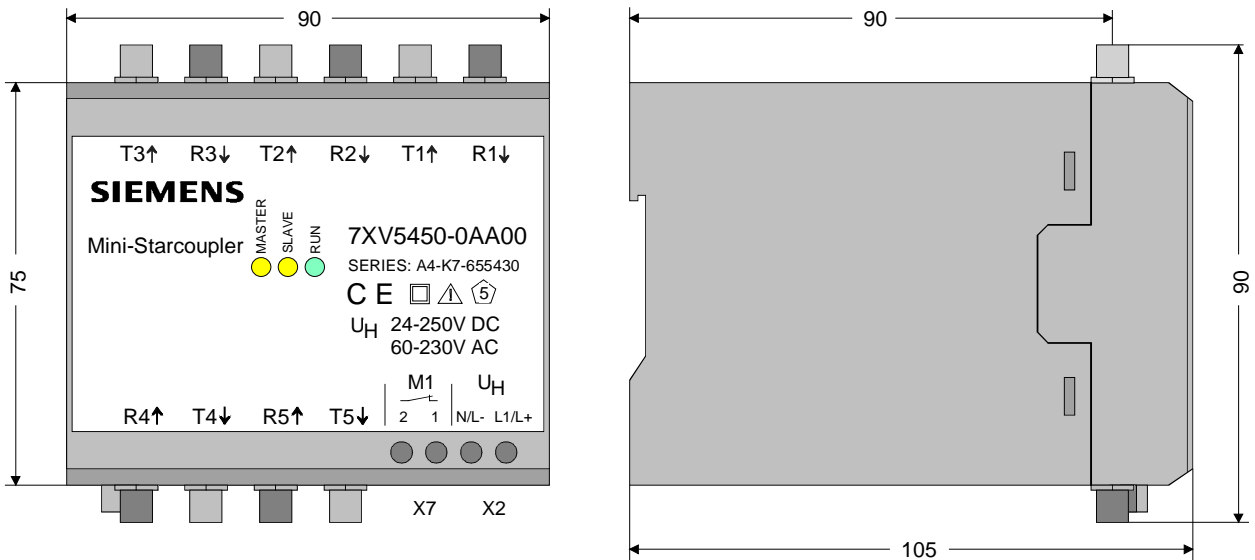

Fig. 1: Dimension Drawings

### 3.9 Ordering Data

Name	Order-No.
<b>Mini-Starcoupler</b> with 1 FO-Interface (input) and 4 FO-Interface (output) and 1 RS232-Interface	<b>7 X V 5 4 5 0 - 0</b> <input type="text"/> <b>A 0 0</b>
<b>Optical In- / Output</b>	<input type="text"/>
BFOC-ST connector	<b>B</b>

**4 Description of the Functional Unit**

The housed signal converter is a hard-wired and tested functional unit. It is provided with a snap-on mounting device for a 35 mm DIN EN 50022 rail and with screw-type terminals for safe connection of the auxiliary power supply. The RS232 interface is connected either to screw-type terminals or to the 9-pin SubD socket. The fiber-optic channel are connected by BOFC-ST terminals. The unit is free of silicone and halogen as well as flame-retardant.

**4.1 Terminal Assignment**

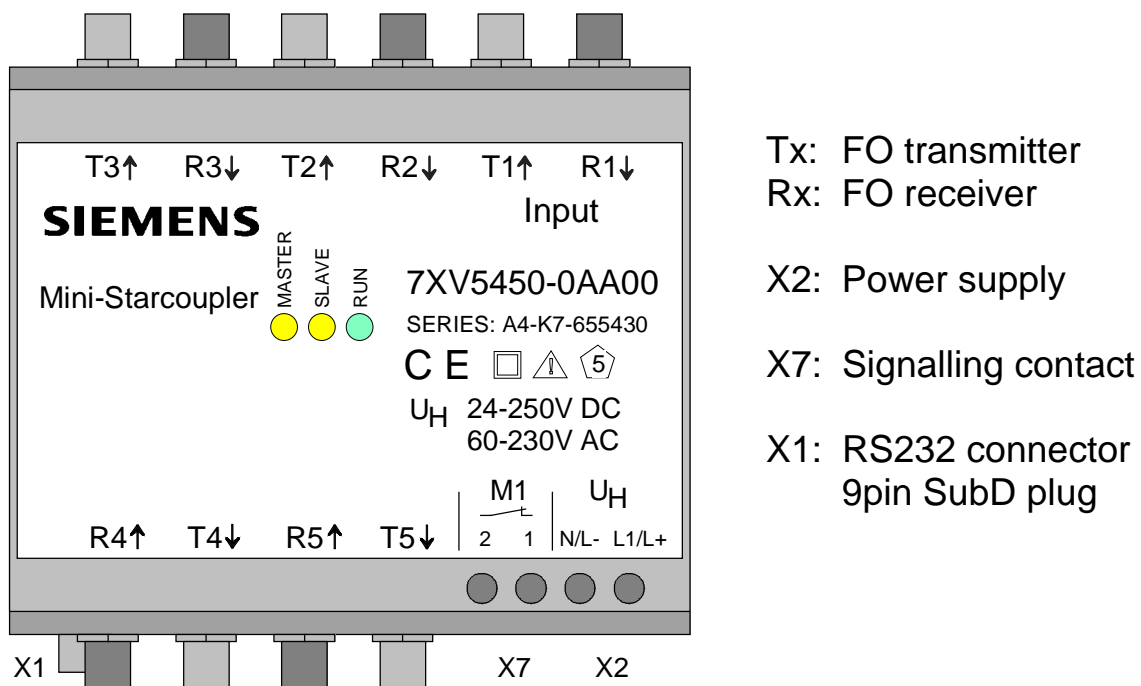

Fig. 2: Terminal Assignment

## 4.2 Screw-type terminals X2, X7

Pin	Assignment	Symbol
X2, Pin 1	Power supply pin 1 (L+)	DC: L+ AC: L
X2, Pin 2	Power supply pin 2 (L-)	DC: L- AC: N
X7, Pin 1	Relay contact pin 1	1
X7, Pin 2	Relay contact pin 2	2

Tab. 1: Screw-type terminals X2, X7, X5

## 4.3 RS232-Connector X1

Pin	Assignment	Symbol
1	not connected	
2	Send data	RxD
3	Receive data	TxD
4	not connected	
5	Signal ground	GND
6	not connected	
7	Activation of the RS232 interface	
8	Signal ground	GND
9	not connected	

Tab. 2: RS232-Connector Sub-D 9-pol. female X1

For activation of the RS232 interface, pins 7 and 8 must be jumpered and switch S1/S2 must be closed.

Note:

If the cascade connection is wired in star topology and S1, switch 1 is ON (ring cascade connection), signal transmission problems may arise.

## 4.4 FO-Connections

The receiving optical connectors are marked with Rx, the transmitting connections with Tx.

## 4.5 Switch positions

The DIP switches can be actuated from outside. For standard applications the mini star coupler can directly be applied with its factory pre-settings, i.e:

- All FO transmitters/receivers set to „light off in idle state“
- Cascading for star configuration
- RS232-interface disabled

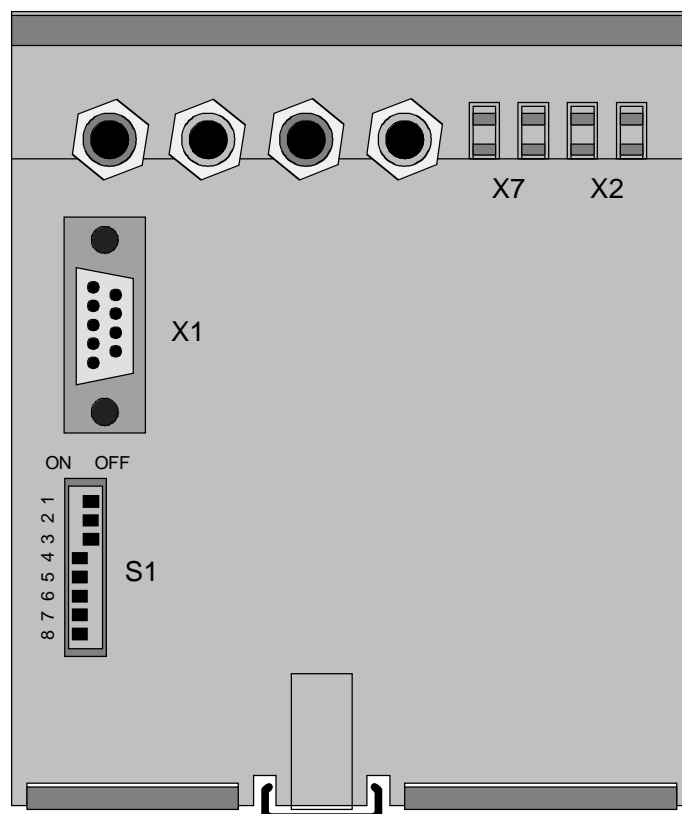

Down view

Fig. 3: Switch positions S1

### Note:

If the switch S1/1 is set to ring configuration, the signals are generally mirrored to the Master (echo). This also applies to the star configuration. With various devices or pc applications this may lead to failures.

**Assignment Switch 1**

Schalter	Stellung		Bedeutung
1	open closed	off on	<b>Star cascade connection</b> Ring cascade connection
2	open closed	off on	<b>RS232 interface blocked</b> RS232 interface can be activated by cable e.g. 7XV5100-4
3	open closed	off on	Not connected
4	open <b>closed</b>	off <b>on</b>	Light ON in idle state Channel 4 <b>Light OFF in idle state Channel 4</b>
5	open <b>closed</b>	off <b>on</b>	<b>Light ON in idle state Channel 5</b> Light OFF in idle state Channel 5
6	open <b>closed</b>	off <b>on</b>	Light ON in idle state Channel 1 <b>Light OFF in idle state Channel1</b>
7	open <b>closed</b>	off <b>on</b>	Light ON in idle state Channel 2 <b>Light OFF in idle state Channel 2</b>
8	open <b>closed</b>	off <b>on</b>	Light ON in idle state Channel 3 <b>Light OFF in idle state Channel 3</b>

Tab. 3: Assignment S1

**Bold print:** Factory settings

## 5 Installation and Commissioning



### **Warning**

When operating electrical devices, certain parts are necessarily under dangerous voltage. Therefore, disregard of the operating notes may cause severe bodily injury or property damage. Installation and electrical connection of the device should be performed by adequately qualified personnel only. In particular, all warnings must be strictly observed.



### **Warning**

Do not look directly in the FO-transmitter diode Tx if you wear optical aid (glasses, contact lens)

### 5.1 Reference to Installation

- The devices are permitted only for operation within enclosed housings or cabinets and places of installation are to be accessible only for qualified personnel.
- The device is clipped on a 35 mm top-hat rail (according to EN50022).
- The installation location should be free of vibrations. The admissible temperature (operation or functional temperature) is to be observed (see technical data).
- Disregard of the temperature range required for proper function may cause malfunction, failure or destruction of the device.

### 5.2 Connection

The chapter 'Connection' describe how to connect data- and power supply cables for a save operation. For the electrical connection the regulations on the raise of heavy-current installations are to be observed.

### 5.2.1 Power supply X2

The wires for the auxilliary voltage are screwed on terminal X2 at he bottom side of the device. The assignment of the terminals is printed at the front side or can be read in this manual. Because the device has no ON/OFF switch this switch must be installed external if it's necessary.

Connection to screw terminals:

Terminal cross section:	max. 2,5 mm <sup>2</sup>
Stripping length:	3 bis 5 mm
Cable cross section: (Single core cable or litz wire)	0,14 bis 1,5 mm <sup>2</sup>

### 5.2.2 Alarm relay terminals X7

X5 offers a potential free contact, which is closed if the device fails. The loss of the power supply is a device failure. The wires for the alarm contacts are screwed on terminal X7 at he bottom side of the device. The assignment of the terminals is printed at the front side or can be read in this manual.

Connection to screw terminals:

Terminal cross section:	max. 2,5 mm <sup>2</sup>
Stripping length:	3 bis 5 mm
Cable cross section: (Single core cable or litz wire)	0,14 bis 1,5 mm <sup>2</sup>

### 5.2.3 Fibre Optic (FO) connections Rx, Tx

- Only optical fibres prepared according the regulations are to be used. The admissible optical budget is to be observed
- FO-types (only multimode) and max. distance see technical datas.
- Transmitter diodes are printed with Tx.
- Receiver diodes are printed with Rx.
- The FO-cables must be crossed, that means a FO-connection is done between Tx output and Rx input and vice versa.



**Note**

When installing optical fibres the prescribed bending radius is to be observed.

## 5.3 Commissioning

- Clip the signal converter on the top-hat rail according EN 50022 with the help of clip-on mounting. Do not make any changes at the device.
- Check whether the operation data comply with the values on the rating plate. Not change any DIP-switch at the device, before reading this manual.
- Connect FO cable to FO receiver (Rx) and FO transmitter (Tx) with the help of ST plugs. Be carefull when connecting the FO plugs and avoid any dust at the FO – connections.
- Connect to RS232 terminals and screw them for permanent use.
- Connect the alarm relay terminals X7.
- Connect auxiliary power to the terminals X2 (DC: L+ / AC: L1 and DC: L- / AC: N).
- The device is ready for use after switching on the auxiliary power. The green LED `RUN´ lights up.

## 5.4 Maintenance

The signal converter requires no maintainance. For cleaning please use a dry and free of fuzz rag. Put the caps onto the FO-interfaces to avoid dust pollution and interference from sun light or any artifical light source.

**Do not use any liquid agents or substances for cleaning.**



6 Application examples

6.1 Optical star configuration

Several mini-star couplers can be cascaded in the star configuration, to interface with further addressable protection devices. This star configuration can be extended with the corresponding converter to also include a RS485 bus structure (see manual 7XV5650).

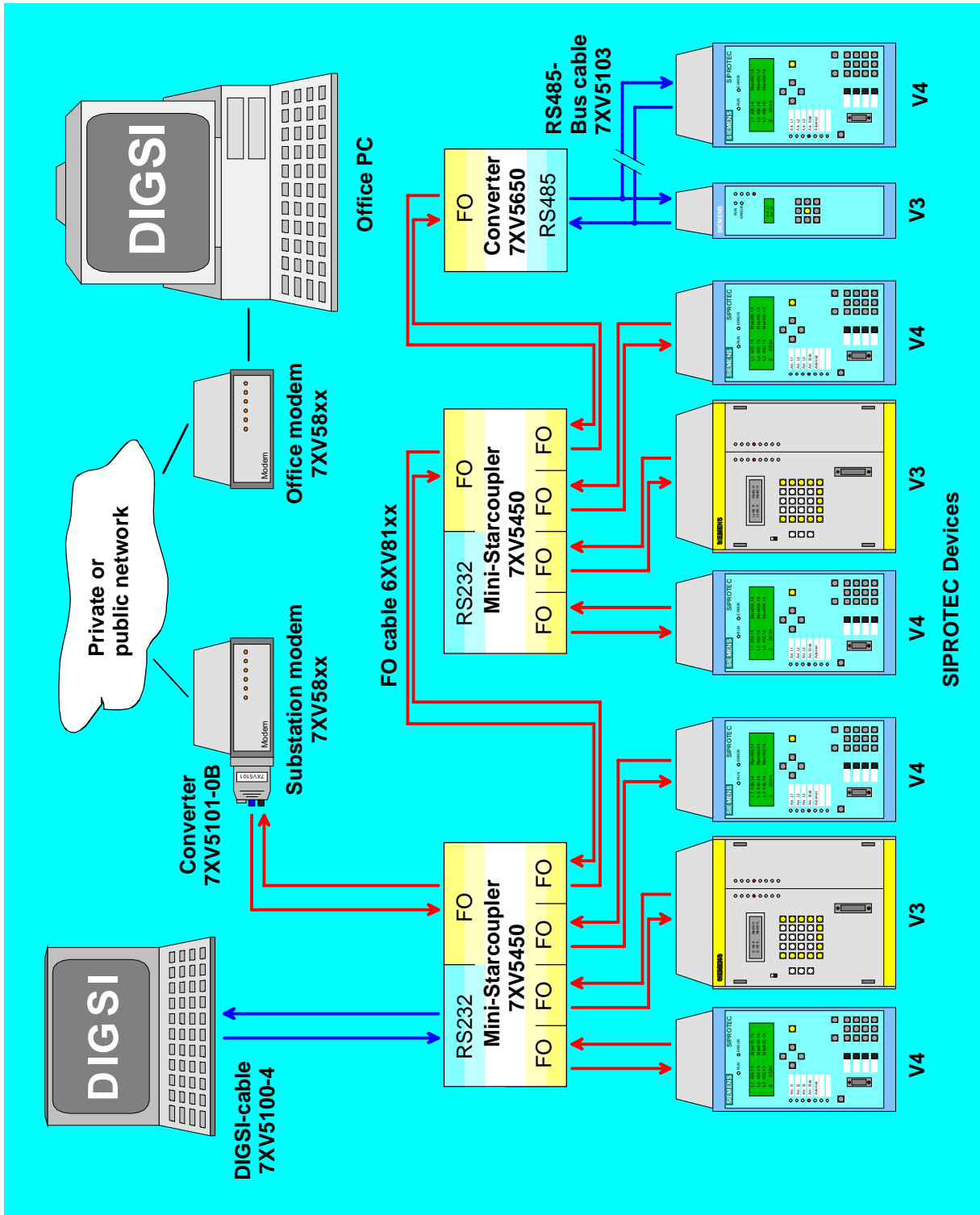

## 6.2 Optical ring configuration

Several mini star couplers can be cascaded in the ring configuration. The transmitter channel 1 must be connected with the receiver channel 1 in the next mini star coupler, and then back to the pc/modem. In this manner a ring configuration is created, whereby one additional output per mini star coupler to a protection device is available. Attention! The data from the pc are mirrored back to the pc or modem.

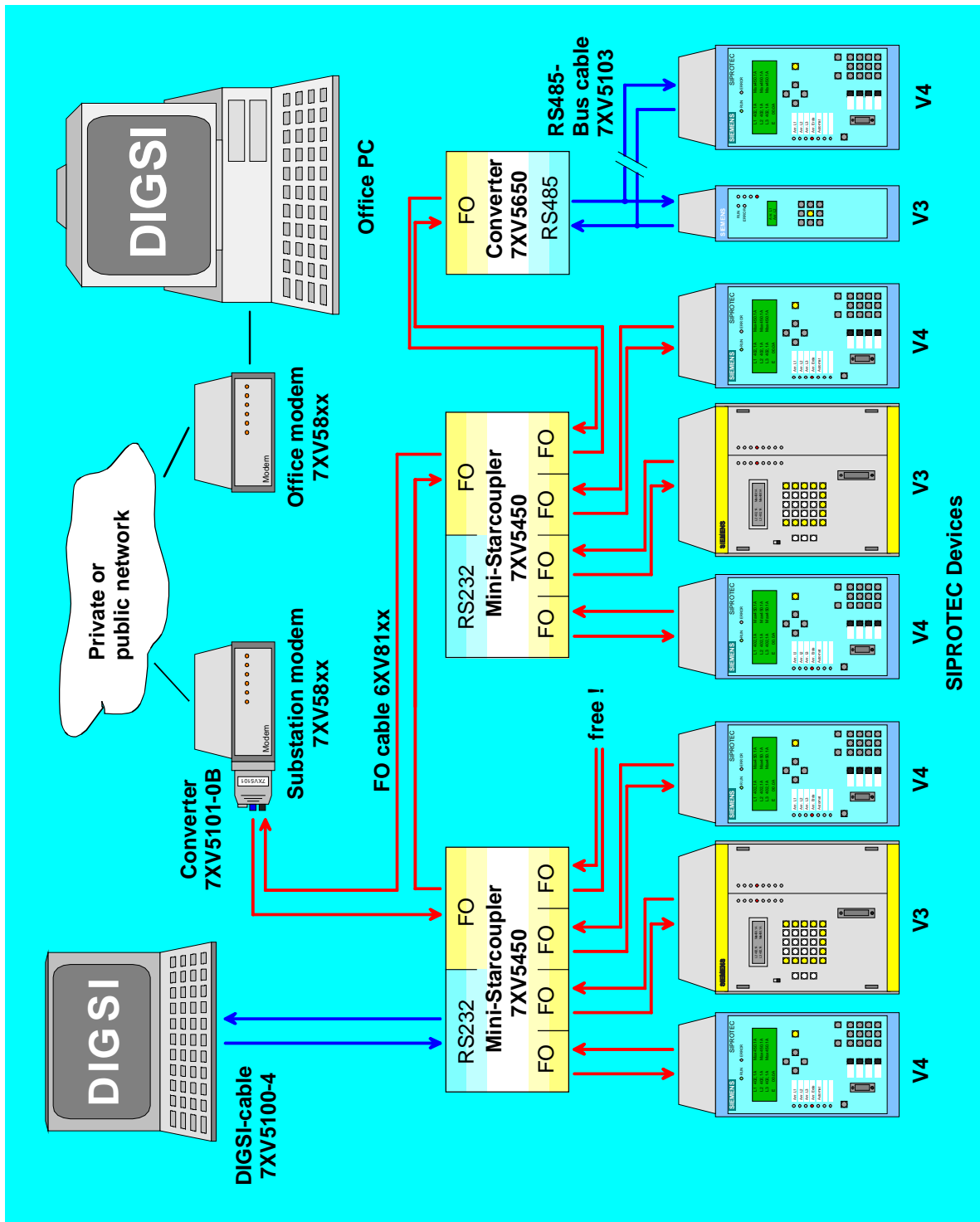

**EG-Konformitätserklärung**  
 EC Declaration of Conformity  
 No E471015-3

Hersteller: Siemens Aktiengesellschaft  
 Manufacturer: Bereich Anlagenbau und Technische Dienstleistungen ATD  
 Technische Dienstleistungen TD

Anschrift: Siemensstraße 33  
 Address: D - 71254 Ditzingen  
 Bundesrepublik Deutschland

Produkt-  
 bezeichnung: Mini-Sternkoppler  
 Product 7XV5450-0xA00  
 description Mini-Starcoupler

**Das bezeichnete Produkt stimmt in der von uns in Verkehr gebrachten Ausführung mit den Vorschriften folgender Europäischer Richtlinien überein:**

*The product described above in the form as delivered is in conformity with the provisions of the following European Directives:*

89/336/EWG Richtlinie des Rates zur Angleichung der Rechtsvorschriften der Mitgliedstaaten über die elektromagnetische Verträglichkeit  
 (geändert durch 91/263/EWG, 92/31/EWG, 93/68/EWG und 93/97/EWG).

*Council Directive on the approximation of the laws of the Member States relating to electromagnetic compatibility (amended by 91/263/EEC, 92/31/EEC, 93/68/EEC and 93/97/EEC)*

73/23/EWG Richtlinie des Rates zur Angleichung der Rechtsvorschriften der Mitgliedstaaten betreffend elektrische Betriebsmittel zur Verwendung innerhalb bestimmter Spannungsgrenzen (geändert durch 93/68/EWG)

*Council Directive on the approximation of the laws of the Member States related to electrical equipment designed for use within certain voltage limits (amended by 93/68/EEC)*

Die Konformität mit den Richtlinien wird nachgewiesen durch die Einhaltung folgender Normen:

*Conformity to the Directives is assured through the application of the following standards:*

Referenznummer <i>Reference number</i>	Ausgabedatum <i>Edition</i>	Referenznummer <i>Reference number</i>	Ausgabedatum <i>Edition</i>
EN 50081-1	1992	EN 50082-2	1995
EN 61010	1993		

Ditzingen, den / the 20. August 1998  
 Siemens AG

Pust, GL /Pflugfelder, GL

  
 Unterschrift  
 signature

Gottwald, Kaufm. HGL

  
 Unterschrift  
 signature

Name, Funktion  
 Name, function

Diese Erklärung bescheinigt die Übereinstimmung mit den genannten Richtlinien, ist jedoch keine Zusicherung von Eigenschaften. Die Sicherheitshinweise der mitgelieferten Produktdokumentation sind zu beachten.

*This declaration certifies the conformity to the specified directives but contains no assurance of properties. The safety documentation accompanying the product shall be considered in detail*

If you have any notes or questions on this product please contact us under the following address:

**Siemens AG**

Power Transmission and Distribution  
Power Automation

Depart. PTD PA 13  
Postfach 4806  
D-90026 Nürnberg

Telefax (+49 911) 433-8301

Further informations regarding our products in the INTERNET under:

<http://www.SIPROTEC.com>

or please visit our Download Area which is part of our WEB-site, where also the latest version of this manual is available as a PDF-file.