

S

Two-channel Binary Signal Transducer 7XV5653-0BA00

Operating Instructions



Table of Contents

0	General Notes	3
1	Operating instructions	10
1.1	Scope of application	10
1.2	Applications	14
1.2.1	Example of applications	14
1.2.2	Binary signal transmission via leased line modem LOGEM928 and LGH28.8D (firmware 4.13)	16
1.2.3	Binary signal transmission via leased line modem MT2834BLG (firmware 3.16d)	20
1.3	Technical data	22
1.4	Description of the functional units	26
1.4.1	Position and assignment of the terminals	26
1.4.2	Switch positions and RS232 interface	28
1.4.3	Dimensional drawings	33
1.5	Ordering data	34
1.6	Installation and commissioning	35
1.7	Settings	37
1.8	Maintenance	37

List of Illustrations

Fig. 1: Example of application	14
Fig. 2: Assignment of connecting cable modem - binary signal transformer	18
Fig. 3: Position and assignment of terminals	26
Fig. 4: Position of the switches	28
Fig. 5: Switching threshold of the binary inputs	32

List of Tables

Tab. 1: Binary inputs	13
Tab. 2: Connector and cable for two-wire leased line operation	17
Tab. 3: Connector and cable for four-wire leased line operation	21
Tab. 4: Screw-type terminals	27
Tab. 5: RS232 interface, 9-pole sub-D socket	29
Tab. 6: S1, DIP switch (2)	29
Tab. 7: S2, DIP switch (8)	30
Tab. 8: Switching threshold of the binary inputs	32

0 General Notes

This manual includes all information required for the intended use of the products described therein. It is intended for technically qualified personnel who are especially trained or have special knowledge on the fields of instrumentation, control and automatic control engineering (in the following called automation). The knowledge and the technically correct interpretation of the safety instructions and warnings included in this manual are prerequisite for safe installation and commissioning, as well as for the safety during operation and maintenance of the product described. Only qualified personnel as defined overleaf have the technical knowledge required to interpret and apply the general safety notes and warnings correctly in the individual cases. This manual is an integral part of the delivery. For reasons of better overview, however, it cannot take into account every detail for all design types of the product described and cannot consider every conceivable situation with regard to installation, operation or maintenance. For further information or if special problems should arise, which are not treated precisely enough in this document, please contact your local Siemens office or send your request directly to the address stated on the last page of this manual.

Furthermore, we wish to point out that the contents of this product documentation are neither part of any previous or current agreement, promise or legal relationship, nor do they imply any modifications thereto.

.

Explanation of the symbols:



Read the documentation.

To be operated only by qualified personnel.



Double insulation



Warning!

It is inevitable during the operation of electrical devices that parts of these devices are under dangerous voltage. If the warning notes are not observed severe bodily injuries or considerable property damages can therefore occur. Only appropriately qualified personnel should operate this device. The faultless and safe operation of this device requires proper transport, storage, mounting and installation as well as careful operation and maintenance. Modules and devices are tested with 3.7 dVAC and 5.2 kVDC with regard to their dielectric strength.

QUALIFIED PERSONNEL

In case of tampering with the device/system or disregard of the warnings given in this manual severe bodily injuries or considerable property damage can occur. Only appropriately qualified personnel may mesh with this device/system. Qualified personnel as defined in the safety notes of these operating instructions or on the product itself are persons who

- are either personnel involved in planning and configuration activities and thus accustomed with the safety concepts of automation and protection relaying;
- operating personnel instructed in operating automation devices who know the contents of these operating instructions that relate to operation;
- or commissioning and service personnel who are qualified for repairing this kind of automation devices or authorized to perform commissioning, grounding and labelling of circuitries and devices/ systems in accordance with the relevant standards for technical safety.

Safety Notes

These operating instructions contain notes that are to be complied with for your personal safety as well as to avoid property damages. These notes are marked by a triangular warning symbol and the different degrees of danger are categorized as follows:

Danger

Disregard of the corresponding precautionary measures will cause death, severe bodily injury or considerable property damage.

Warning

Disregard of the corresponding precautionary measures may cause death, severe bodily injury or considerable property damage.

Attention

Disregard of the corresponding precautionary measures may lead to slight bodily injury or minor property damage.

Note

Shall draw your attention to special information on the product, product handling or the corresponding section of the documentation.

Qualified personnel

Commissioning and operation of the equipment is to be performed by qualified personnel only. In the context of safety notes in this manual, the term qualified personnel refers to persons authorized to perform commissioning, grounding and labelling of devices, systems and electrical circuitries.

Intended Use

Please observe the following:

Warning

The device must be operated only within the scope of its intended use according to these operating instructions and in connection with third-party equipment or compounds recommended or accepted by Siemens. Faultless and safe operation of the product require proper transport, storage, mounting and installation as well as careful operation and maintenance.

Exclusion of liability

The contents of this document have been reviewed on their compliance with the hardware and software described therein. Yet, deviations cannot be excluded, so that we cannot guarantee full compliance. The specifications in this document are, however, reviewed at regular intervals. Necessary corrections will be included in the next edition. You are invited to send us your suggestions for improvement.

Copyright

Copyright Siemens AG 1999. All rights reserved.

Transmission or reproduction of this document, as well as the use and forwarding of its contents is not permitted without express written authority. Offenders will be liable for damages. All rights, including rights created by patent grant or registration of a utility model or design, are reserved.

Subject to technical changes without notice.

Notes concerning CE labelling

- **EU guideline EMC 89/336/EWG**

For the interface connection as described in these operating instructions the following is valid: Products with the CE label comply with the requirements of EU guideline 89/336/EWG "electromagnetic compatibility" and the harmonised European norms (EN) stated therein.

The EU conformity declarations are available according to above mentioned EU guideline, paragraph 10, for competent authorities at:

Siemens AG
Industrial and Building Systems Group
ATD TD STG 32
PO Box 1448
D-71243 Ditzingen

- **Scope of application**

The binary signal transducer is designed for industrial use and meets the following requirements:

Scope of application	Requirements on	
	Interference emission	Interference immunity
Industry	EN 50081-2 : 1993	EN 50082-2 : 1995

The binary signal transducer can also be used in the residential field (housing, commerce and trade, small businesses):

Scope of application	Requirements on	
	Interference emission	Interference immunity
Residential field	EN 50081-1 : 1992	EN 50082-1 : 1992

- **Observe the installation guidelines**

The binary signal transducer meets the requirements if you

1. follow the installation guidelines for installation and operation as described in the operating instructions.
2. observe also the following rules concerning the installation of the device and the operation of the control cabinets.

- **Installation of the device**

Interface modules are to be installed inside electrical operating areas or in a closed housing (e.g. metal or plastic switch boxes). In addition the device and the switch box (metal box) or at least the top-hat rail (plastic box) on which the module is clipped on are to be grounded.

- **Operating the control cabinets**

To protect the modules from discharge of static electricity personnel must discharge themselves before opening the control cabinets or switch boxes.

Notes for the producer of machines

- **General**

The binary signal transducer is not a machine as defined in the EU guideline "machines". Therefore there is no conformity declaration regarding the EU guideline machines 89/392/EWG.

- **EU guideline machines 89/392/EWG**

The EU guideline machines 89/392/EWG determines the requirements on a machine. Here a machine is seen as a totality of connected parts or devices (also see EN292-1, chapter 3.1).

The binary signal transducer is part of the electrical equipment of a machine and therefore to be integrated in the procedure concerning the conformity declaration by the producer.

1 Operating instructions

1.1 Scope of application

The two-channel bidirectional binary signal transducer converts binary signals with a wide-range input and sends their state serially via a duplex optical fibre to a similar remote converter. In the remote converter the information is instantly put out command contacts. The converter is dimensioned for the application in switchgears and allows an interference-free transfer of signals with fibre optic cables. Faulty operation or transmission failures are safely detected and signaled via an alarm relay. The factory setting of the binary transducer is prepared for direct FO connection via multimode fibre cables.

Technical data

- 2 isolated binary inputs with a wide input voltage range (18V..250VDC).
- 2 isolated command relays with high switching capacity.
- Short operation time due to point-to-point connection (12..118ms), depending on the data speed.
- Interference-free due to FO connection even in an environment with high electromagnetic interference.
- Safe transmission due to protocol communication with monitoring functions.
- Distance up to 3 km via multimode fibre 62,5/125µm.
- Up to 100 km with a monomode fibre if cascaded with the 820/1300nm converter 7XV5461-0BA00.
- Integrated wide-range power supply unit with alarm contact.

Full duplex operation

Binary information is transmitted bidirectional at the same time, e.g. for direction comparison or signal comparison (condition as delivered).

- Alarm relay M1 drops if voltage supply fails.
- If no signal is received from the remote converter an LED indication is done (red LED: ERR) and alarm relay M1 drops.
When operated via modem the binary signal transducer sends further data only after 15 s in order to avoid overstrain of the modems, if the data connection is interrupted by any reason.
Exception: A change of signal at a binary input of the binary transducer is transmitted instantly.

Half duplex operation

Both binary information are transmitted only in one direction via optical fibre. Therefore only one fibre cable is necessary from the input device to the output device.

Transmitter:

(Setting "transmitter only" with S2 / DIP 7 (see table 7))

- Alarm relay M1 drops if voltage supply breaks down.
- No monitoring of the transmission link from the transmitter.

Receiver:

(Setting "send/receive" with S2 / DIP 7 (see table 7))

- Alarm relay drops if voltage supply breaks down.
- If no signal is received from the transmitter steady light lights up as fault indicator (red LED: ERR) and alarm relay M1 drops.

General data

Auxiliary DC or AC power is connected by 2 terminals (N/L, L1/L). The wide range of auxiliary supply (24 - 250V DC and 60 - 230V AC) allows the connection to all common substation batteries or AC mains voltages (without jumpers in the device).

An LED display for the operating voltage (green LED: RUN) is attached to the front, to indicate correct operation.

Data transfer

The optical interface works in positive logic (light OFF in idle state), incoming light is treated as active = 1 (high). For the adaption to systems with negative logic a switch is integrated which allows the negative logic setting (FO interface).

Position as delivered is positive logic (lights OFF in idle state).

Both convertes must operate in the same logic. It is recommended to remain the factory setting.

FO connection

The optical fibre cables are connected to the converter via ST-connectors.

Connecting to the serial RS232 interface

Connecting to the RS232 interface disconnect the FO-transmitting and set the communication to seriell interface.

The Connection to the serial interface of the converter can be done via a serial 7XV5100-4 cable.

For use with an other cable, Pins 7 and 8 of this cable must be bridged and Pin 1 and 4 (X1 at BST) has no assignment.

Binary inputs

Both binary inputs BI-1 and BI-2 operate with a wide range of input voltage. Logic high "1" is a voltage level of 24V-250V DC / -15% +20% with polarity reversal protection and a pick up threshold at 18V. The threshold can be raised in exceptional cases (e.g. long and unshielded lines and high electrical interference, see table 8 and fig. 7).

Logic low "0" is a voltage level below the threshold. The associated yellow LEDs (BI-1, BI-2) light up if the corresponding binary input is activated (if it is in a logic high state).

Binary input 1 BI-1	Binary input 2 BI-2	LED BI-1	LED BI-2	LED K1	LED K2
Activ		Lights up			
	Activ		Lights up		

Table 1: Binary inputs

The LEDs K1, K2 show the state of the outputs contacts wich are set by the binary inputs from the remote converter via a serial telegramm transmitted via fibre optic cables or RS232 connection (e.g. modem with RS232 interface).

1.2 Applications

1.2.1 Example of applications

With the help of the binary signal transducer 2 binary signals can be detected and directly transmitted over FO distances up to 3 km via multimode cables and can be put out in the remote station via relay contacts. A repeater 7XV5461 is available for transmission with mono-mode fibres up to 100 km (fig. 2a).

Transmission can, however, also be carried out via modem or PCM devices (fig. 2b) after connecting the equipment to the RS232 interface.

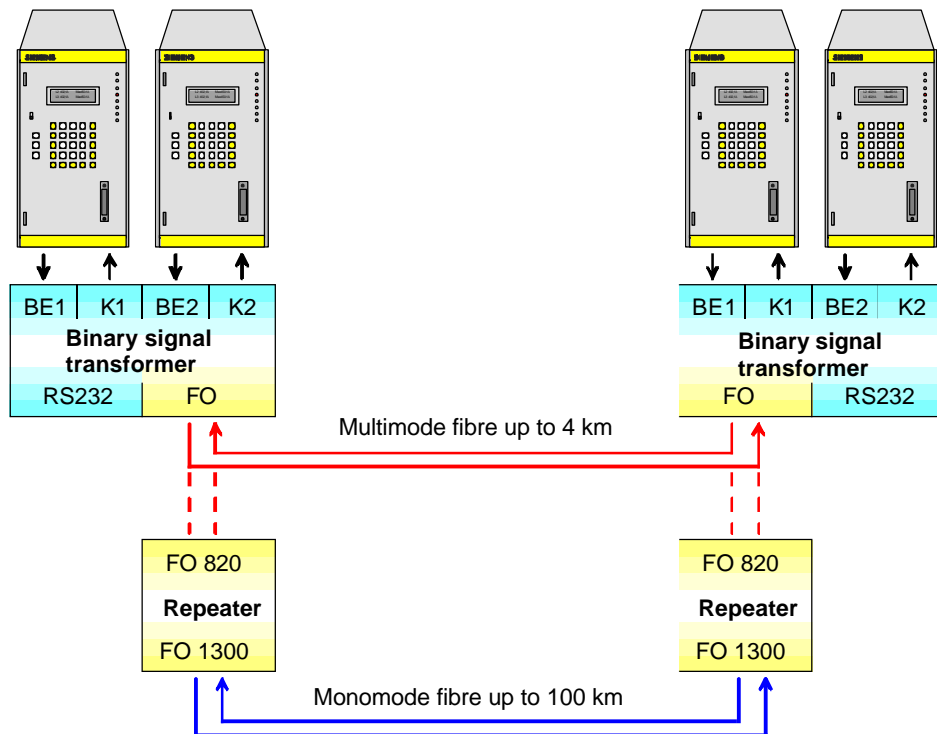

Fig. 1a: Example of application for direct fibre connections with multimode or single mode fibre.

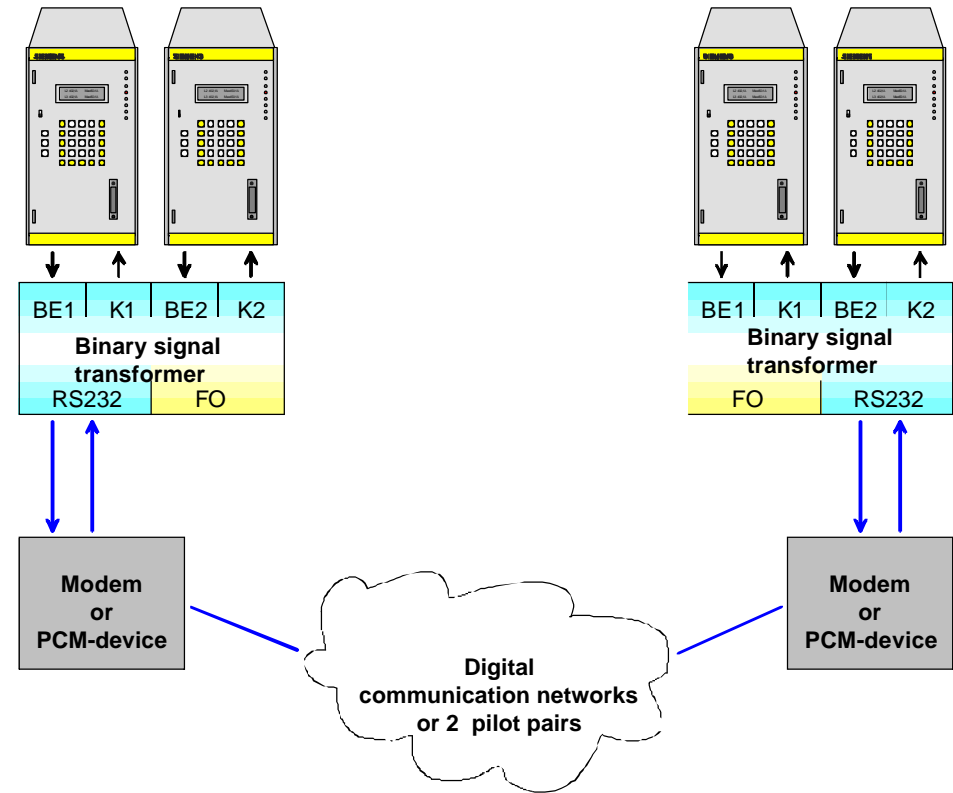
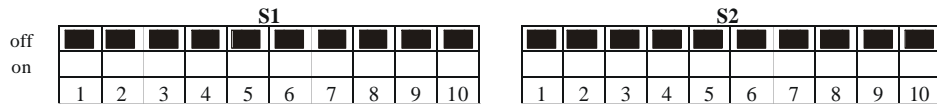

Fig. 1b: Example of application for a serial connection via modem or a comms-device.

1.2.2 Binary signal transmission via leased line modem LOGEM928 and LGH28.8D (firmware 4.13) in two-pilot wire operation

• Setting the DIP switches at the modem

Before the modem is initialized the DIP switches are to be set as follows:



Attention! Switch off the modem for this setting.

The changed settings are request only with the switching on of the modem.

• Initialization of the modems

The modems are to be initialized before commissioning. This is best be done with the help of a terminal program, e.g. Hyperterminal.

- A null modem cable is needed for the connection between PC and modem where the terminal program runs.
- Reset the modem before initializing the modem (press the switch when connecting the auxiliary supply until LED "A/O" flashes).
- Put in the following text string into Hyperterminal and press ↵ to send them to the modem. Then the modem answers with OK.
- Than you can disconnect the modem from the PC interface and connect the serial interface of the modem with the serial interface of the converter.

For 19200 baud:

Modem A: AT &F0 \N0 \Q0 &D0 F40 S51=11 %C0 S20=0 &L2 E0 Q1 &W ↵

Modem B: AT &F0 \N0 \Q0 &D0 F40 S51=11 %C0 S20=0 &L3 E0 Q1 &W ↵

Explanation of the commands:

&F0	= Load factory setting
\N0	= Normal mode (without data compression, no error correction)
\Q0	= No flow control
&D0	= Control cable S1/108 is ignored
F40	= Transmission mode V.34
S51=11	= Fixed baud rate to terminal device (RS232 interface)
%C0	= No Data compression
S20=0	= Ignore signs in the command phase
&L2	= Calling modem
&L3	= Accepting modem
E0	= No echoe
Q1	= Switch off result codes
&W	= Save settings in the EEPROM of the modem

Note:

Two-wire operated transmission was tested successfully with these settings.

The baud rate chosen must also be adjusted at the two binary signal transducers (also see setting at binary transducer 7XV5653).

Connector and cable for two-wire leased line operation

For two-wire leased line operation use the supplied cables with the imprint *leased line*. The RJ-11 connector is to be connected to the socket marked with *LEASED*.

The other end of the cable is to be connected to a TAE-N coded telephone outlet box as follows.

TAE-N 1	TAE-N 2
1	1
2	2

Tab.2: Connector and cable for two-wire leased line operation

• **Settings at the binary signal transducer 7XV5653**

When binary signals are transmitted baud rates and data formats of both RS232 are to be set as equal.

The baud rate of the RS232 interface should not be higher than the rate of the transmission link. If settings are chosen as shown in these instructions the modems are connected at a rate of 28800 baud. Standard setting 8N1 was chosen as data format between the converter and the modem.

For 19200 bd:

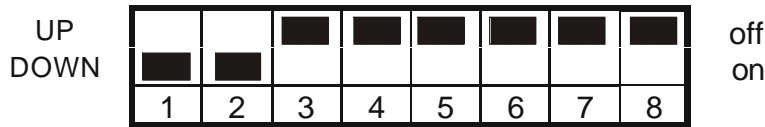

• **Connecting cable modem - binary signal transducer 7XV5653**

The cable from the modem (25-pole pin) to the binary signal transducer (9 pole pin) has the following connections and bridges:

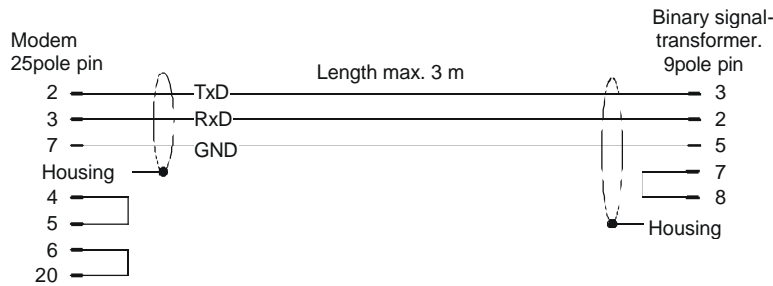
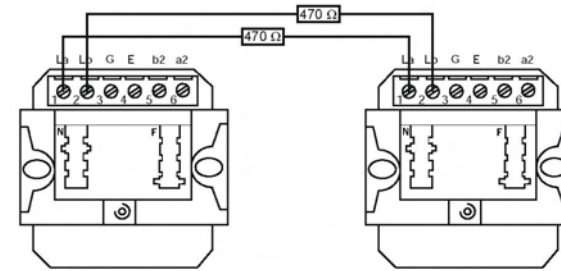

Fig. 2: Assignment of connecting cable modem - binary signal transducer

Example for testing the modem communication:

The modems can not be connected directly via a short pilot pair in testing/laboratory mode. In this case the connecting cable should have a small resistance transmission errors otherwise the receiver of the modem is disturbed by a too high transmission level. For this reason we recommend to install a resistor of 470 Ω in each of the connections (also see figure below).



1.2.3 Binary signal transmission via leased line modem MT2834BLG by company MultiTech in four-wire operation (firmware 3.16d)

• **Setting the DIP switches at the modem**

Before the modem is initialized the DIP switches are to be set as follows:

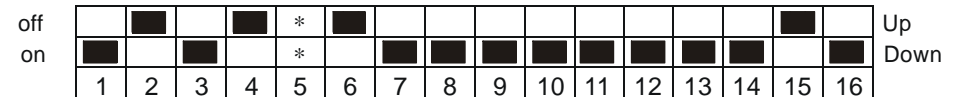

*) modem-1 DIP switch 5 off, modem-2 DIP switch 5 on

Attention! Switch off modem for setting. The changed settings are adopted only with the switching on of the modem.

• Initialization of the modems

The modems are to be initialized before commissioning. This is best be done with the help of a terminal program, e.g. Hyperterminal.

- A null modem is needed for the connection between PC and modem.
- Put in the following data into Hyperterminal and press ↵ to send them to the modem. The modem will reply with OK.

For 19200 baud:

```
AT&FE0#F0$SB19200MB19200&E14&E3&W0↵
```

Explanation of the commands:

AT	= If connected correctly the modem answers with OK
&F	= load factory settings
\E0	= No echoe
#F0	= Stabilization of performance speed
\$SB19200	= Fixed baud rate to terminal device (RS232 interface)
\$MB19200	= Fixed baud rate between modem-1 and modem-2
&E14	= Data compression deactivated
&E3	= Switch off flow control
&W0	= Save settings

Note:

Four-wire operated transmission was tested successfully with these settings.

The baud rate chosen must also be adjusted at the two binary signal transducers (also see setting at binary transducer 7XV5653).

Connector and cable for four-wire leased line operation

For four-wire leased line operation use the supplied cables with the imprint *leased line*. The RJ-11 connector is to be connected to the socket marked with *LEASED*.

The other end of the cable is to be connected to a TAE-N coded telephone outlet box as follows.

TAE-N 1	TAE-N 2
1	6
2	5
5	2
6	1

Tab.3: Connector and cable for four-wire leased line operation

1.3 Technical data

Mechanical design Housing Dimensions Weight Degree of protection according to EN60529 Housing Terminals	Plastic EG90 see dimensional drawings approx. 250g IP 20 plastic IP 20
Auxiliary power U_H Connection Rated input voltage - DC voltage - AC voltage Degree of protection Power consumption - DC voltage - AC voltage Internal fuse, not exchangable Status display	2-pole connector Phoenix 24 V - 250 V DC \pm 20 % 60 V - 230 V AC \pm 20 % / 45-65 Hz II at U _H = U _{HN} ; typical value 3 W 3,5 VA 1,25 AT 1 green operating LED (RUN)
RS232 connection Connection Maximum baud rate Minimum baud rate	9-pole sub-D, socket 115200 baud 1200 baud

Optical interface Optical inputs/outputs Optical connection Data display Wave length Launched power	1 transmitter, 1 receiver as-delivered position: light off in idle state Transmitter ST : HFBR 1404 Receiver ST : HFBR 2402 ST (protective caps made of plastic) None 820 nm 50/125 μ m: -19dBm multimode fibre 62,5/125 μ m: -15dBm multimode fibre 200 μ m; -6,2dBm HCS fibre -30dBm
Sensitivity Optical budget Maximum distance that can be spanned Maximum baud rate Minimum baud rate	10dB (+3 dB system budget) 3 km mit 62,5/125 μ m FO 115200 baud(recomm. for fibre conn.) 1200 baud
2 binary inputs Connection Switching voltage Power consumption (not depending on voltage) Status display	2-pole connector Phoenix isolated 24-250 V DC -15 %, +20% approx. 2,5mA 1 yellow LED indic. per input (BI-1, BI-2)

2 command outputs	
Relay	MSR relay (K1,K2) 1 floating make relay
Connection	2-pole terminal Phoenix
Switching voltage (nominal voltage)	250 V AC/DC
Switching capacity	50..270W (voltage dependent), 1000 VA
Switching current	5 A permanently 30 A for 0,5s
Status display	each 1 yellow LED (K1,K2) if relay displayed
Response time in FO operation (event binary input transformer A to reaction binary output at transformer B)	
1200 baud	118 ms
2400 baud	63 ms
4800 baud	34 ms
9600 baud	20 ms
19200 baud	17 ms
38400 baud	15 ms
57600 baud	14 ms
115200 baud	12 ms
	*(recomm. for direct fibre optic connections)
Response time in modem operation (modem MT2843BLG) (event binary signal transformer A to reaction binary signal transformer B)	
9600 baud	102 ms
19200 baud	71 ms
Fault indicator output relay	
Relay	MSR relay (M1) 1 normally closed contact
Connection	2-pole terminal Phoenix
Switching voltage (nominal voltage)	250 V AC/DC
Switching capacity	30 W/VA
Switching current	1 A permanently
Fault indicator	LED (ERR) permanently red in case of faulty data transmission or if data cannot be used.

Safety	
According to DIN EN 61010 part 1	
Overtoltage category	III (3,7kVAC / 5,2kVDC)
Degree of pollution	2
Fire resistance classification according to UL 94	V0
Dielectric tests	
EN61010	
Voltage test (routine test)	3,1 kV DC / 1s (with by-pass capacitors)
- Power to relay to binary inputs	2,0 kV AC / 50Hz / 1s (without by-pass capacitors)
- Power to RS232	
- RS232 to relay to binary inputs	
Electromagnetic immunity tests	
EN 50082-2	
Electromagnetic emission tests	
EN 50081-1	
Admissible environmental conditions	
Operating temperature	-5°C to +55°C
Storage temperatur with factory packing	-25°C to +70°C
Transport temperature with factory packing	-25°C to +70°C
Humidity	10% to 93% (moisture condensation not admissible)
Air pressure	0 to 3000 asl

1.4 Description of the functional units

The signal converters inside the housing are hard-wired and tested functional units. They are provided with a clip-on mounting for a DIN EN 50022 top-hat rail 35 mm. Auxiliary power supply can be safely connected at the screw-type terminals. The FO channels are adapted via the ST-terminals. The RS232 interface is connected via a 9-pole sub-D socket. The devices are free of silicone and halogen as well as flame-retardant.

1.4.1 Position and assignment of the terminals

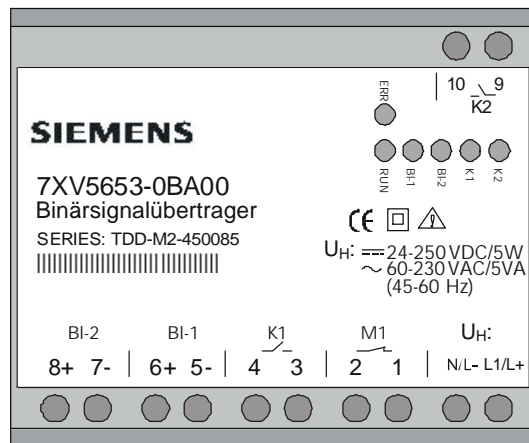

Fig. 3: Position and assignment of the terminals

Terminal assignment

Pin	Meaning	Abbreviation
L+	Voltage supply L+	AC: L1 DC: L+
L-	Voltage supply L-	AC: N DC: L-
Pin 1	Fault signal relay contact M1	1 (NC contact)
Pin 2	Fault signal relay contact M1	2 (NC contact)
Pin 3	Command relay K1	3 (NO contact)
Pin 4	Command relay K1	4 (NO contact)
Pin 5-	Binary input 1-	BI-1-
Pin 6+	Binary input 1+	BI-1+
Pin 7-	Binary input 2-	BI-2-
Pin 8+	Binary input 2+	BI-2+
Pin 9	Command relay K2	9 (NO contact)
Pin 10	Command relay K2	10 (NO contact)

Tab. 4: Screw-type terminals

1.4.2 Switch positions and RS232 interface

The DIP switches can be operated from outside.
Position of the DIP-Schalter: View from the front

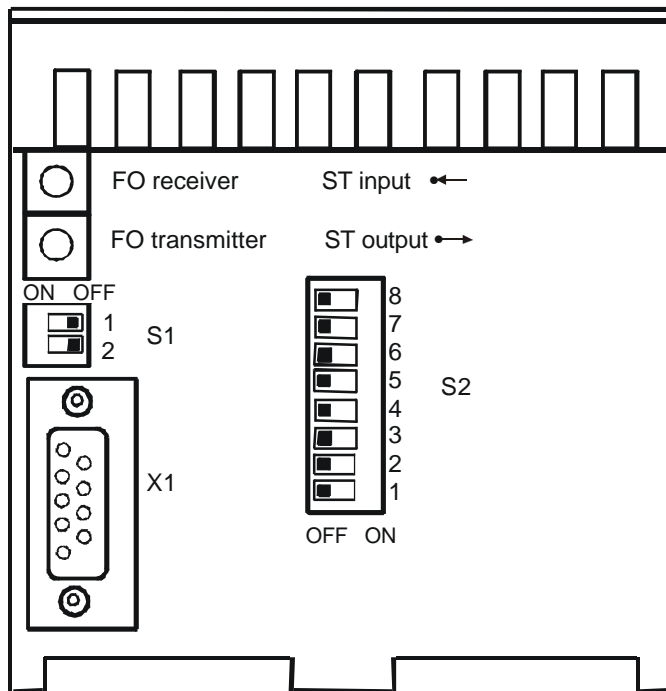

Fig. 4: Positions of the switches

Pin	Description	Abbreviation	Direction as DTE
1	-	-	No connection
2	Receive data	RxD	In ←
3	Transmit data	TxD	Out →
4	-	-	No connection
5	Signal ground	GND	-
6	-	-	-
7	Signal ground	GND	-
8	Active interface selection	Bridge	Input
9	-	-	-

Table 5: RS232 interface, 9-pole sub-D socket

Explanation

Switch	Meaning	Remark
Not connected	FO connection active	Pin 8 open
Factory setting is FO connection	RS232 connection active	Bridge pin 8 – 7 At the converter input

DIP switch (S1, S2)

Switch	Position	Meaning
1	Open	= off Light off in idle state: FO receiving
	Closed	= on Light on in idle state: FO receiving
2	Open	= off Light off in idle state: FO transmitting
	Closed	= on Light on in idle state: FO transmitting

Table 6: S1, DIP switch (2)

Bold type = factory setting

DIP 8	DIP 7	DIP 6	DIP 5	DIP 4	DIP 3	DIP 2	DIP 1	Meaning
-	-	-	-	-	ON	ON	ON	1200 baud
-	-	-	-	-	ON	ON	OFF	2400 baud
-	-	-	-	-	ON	OFF	ON	4800 baud
-	-	-	-	-	ON	OFF	OFF	9600 baud
-	-	-	-	-	OFF	ON	ON	19200 baud
-	-	-	-	-	OFF	ON	OFF	38400 baud
-	-	-	-	-	OFF	OFF	ON	57600 baud
-	-	-	-	-	OFF	OFF	OFF	115200 baud
-	-	-	-	ON	-	-	-	8E1
-	-	-	-	OFF	-	-	-	8N1
-	-	-	ON	-	-	-	-	Block MA
-	-	-	OFF	-	-	-	-	Enable MA
-	-	ON	-	-	-	-	-	Testmode on
-	-	OFF	-	-	-	-	-	Testmode off
-	ON	-	-	-	-	-	-	Transmitter only
-	OFF	-	-	-	-	-	-	Transmit/receive
ON	-	-	-	-	-	-	-	Bootloader on
OFF	-	-	-	-	-	-	-	Bootloader off

Table 7: S2, DIP switches (8)

bold type = factory setting

Explanation:

8E1 = 8 data, even parity, 1 stop bit

8N1 = 8 data, no parity, 1 stop bit

Testmode on:

The binary signal transducer runs a self-test. If the binary input is activated (voltage impressed) the binary LED lights up (BI-1 or BI-2) and the corresponding relay (K1 or K2) with associated LED (K1 or K2) is activated. The diagnosis of the memory test and the position of the DIP switches are put out on the serial interface (RS232) and can be displayed with a terminal programm, running on a PC.

Testmode off: The binary signal transducer is ready for normal operation.
Block MA: Block message outputs, the relays are not controlled.
Enable MA: Normal operation, message outputs are not put out.
Transmitter only: The binary signal transducer acts as transmitter only.
 Missing incoming signals are not reported as comm. errors.

Setting of the baud rate via S2:

The baud rate (position of the DIP switches) is queried once after the switching on. During active testmode the baud rate is queried continuously and set anew.

Baud rate during operation: set baud rate via DIP switch 0..2, shortly switch on and off DIP switch 3 (testmode).

Pitch up threshold of the binary inputs

To change the threshold of the binary inputs the binary signal transducer has to be opened and jumpers have to be changed.



Warning !

THE DEVICE MUST NOT BE OPERATED WHEN OPEN.
Remove Powersupply in this case!

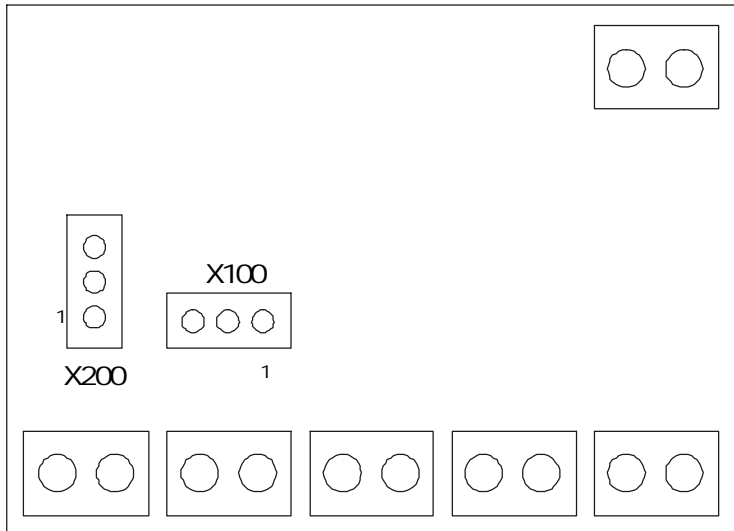

Fig. 5: Switching threshold of the binary inputs

To change the jumper positions, the following instructions must be observed:

- Disconnect the device
- Remove the cover of the housing
- with a small screwdriver, force the clips of the cover carefully toward inside of the device
- change the jumper positions as shown in table 8
- snap the cover back into its position

Jumper	Position	Pick up threshold	Binary inputs
X100	1-2	17 V	1 (BI-1)
X100	2-3	70 V	1 (BI-1)
X200	1-2	17 V	2 (BI-2)
X200	2-3	70 V	2 (BI-2)

Table 8: Switching threshold of the binary inputs
bold type = factory setting

1.4.3 Dimensional drawings

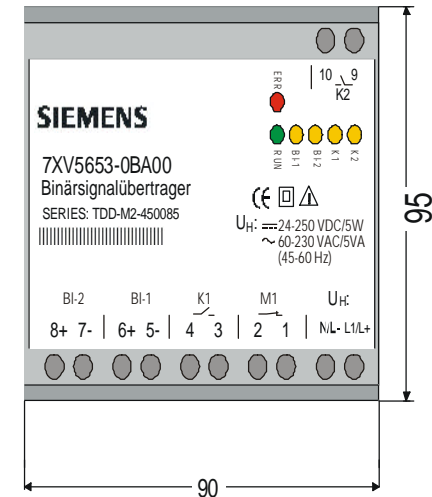
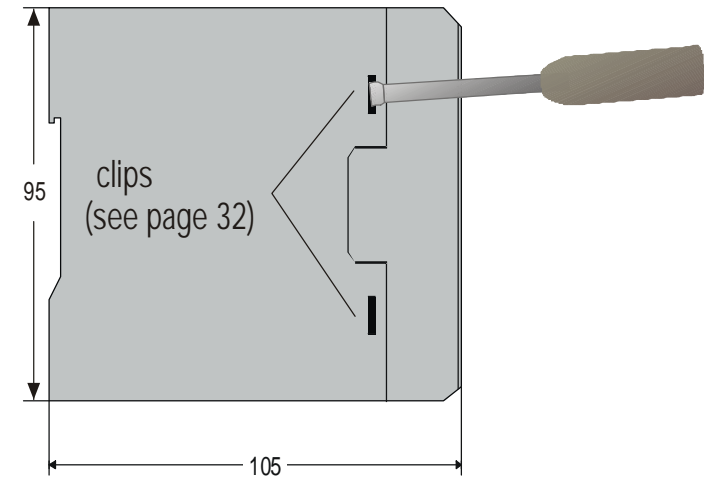

1.5 Ordering data

Name	Order No.	Code
Binary signal transducer 7XV two-channel	5653 – 0BA00	
2 binary inputs, 2 command inputs, 1 fault signal output via terminals		

1.6 Installation and commissioning



Warning!

When operating electrical devices, certain parts of these devices are necessarily under dangerous voltage. Therefore, disregard of the operating notes may cause severe bodily injury or property damage. Installation and electrical connection of the device should be performed by adequately qualified personnel only. In particular, all warnings must be strictly observed.



Warning !

Do not look directly into the FO transmission diodes when wearing optical aids !!!



Warning !

THE DEVICE MUST NOT BE OPERATED WHEN OPEN.

Installation

- The installation location should be free of vibrations. The admissible ambient temperature (operation or functional temperature) is to be observed (see technical data).
- Disregard of the temperature range required for proper function may cause malfunction of the device and failure of the signal converter.
- Plastic housing, overvoltage category III according to DIN EN 61010 part 1.
- The signal transducer can be clipped on a 35 mm top-hat rail (according to DIN EN 50022).
- The devices are permitted only for operation within enclosed housing or cabinets and the places of installation are to be accessible only for qualified personnel.

Connection

- For the electrical connection the regulations on the erection of heavy-current installations are to be observed.
- The connection of the device is to be carried out according to VDE0100 and VDE0160.
- The auxiliary supply of the device is to be provided with an external disconnecter (switch) for the safety isolation of the power supply and with a safety device (fuse), 2AT or 4AT. The external disconnecter is to be labelled accordingly. A safety cut-out can possibly act in both functions.
- Cable cross section (single-core cable or litz wire):
0,5mm² - 2,5mm²
- Recommended stripping length: 5mm.



Warning !

Any connections with litz wire are to be realised with the help of wire end ferrules with isolation (this avoids fraying).

- Only optical fibres prepared according to the regulations are to be used.
- FO types: see technical data.
- The admissible optical budget is to be observed (see technical data).
- When installing optical fibres the prescribed bending radius is to be observed!

Commissioning

- Check whether the operation data comply with the values on the rating plate.
- Do not make any changes at the device.
- Clip the binary signal transducer on the top-hat rail with the help of the clip-on mounting.
- Connect auxiliary power to terminals UH (DC:L+ / AC:L1) and (DC:L- / AC:N).
- Connect FO cable to FO receiver and FO transmitter with the help of ST-type terminals.
- Or connect RS232 cable.
- The binary signal transducer is ready for use after switching on auxiliary power. The green LED 'RUN' lights up.

1.7 Settings

All settings of the binary signal transducer can be carried out from outside via DIP switches (except pick up voltage of binary inputs). The housing does not have to be opened for this. Exception: Setting of the switching threshold (see chapter 1.4.2).
Description see chapter 1.2.2.

1.8 Maintenance

The binary signal transducer requires no maintenance. Do not use any liquid agents or substances for cleaning.

empty page

EG-Konformitätserklärung
EC Declaration of Conformity

No. E471046-1 / 12.99

Hersteller: Siemens Aktiengesellschaft
 Manufacturer: Bereich Anlagenbau und Technische Dienstleistungen ATD
 Technische Dienstleistungen TD

Anschrift: Siemensstraße 33
 Address: D - 71254 Ditzingen
 Bundesrepublik Deutschland

Produkt- bezeichnung: Binärsignalübertrager 2-kanalig
 7XV5653-0AA00
 Product description

Das bezeichnete Produkt stimmt in der von uns in Verkehr gebrachten Ausführung mit den Vorschriften folgender Europäischer Richtlinien überein:
 The product described above in the form as delivered is in conformity with the provisions of the following European Directives:

89/336/EWG Richtlinie des Rates zur Angleichung der Rechtsvorschriften der Mitgliedstaaten über die elektromagnetische Verträglichkeit
 (geändert durch 91/263/EWG, 92/31/EWG, 93/68/EWG und 93/97/EWG).

Council Directive on the approximation of the laws of the Member States relating to electromagnetic compatibility (amended by 91/263/EEC, 92/31/EEC, 93/68/EEC and 93/97/EEC)

73/23/EWG Richtlinie des Rates zur Angleichung der Rechtsvorschriften der Mitgliedstaaten betreffend elektrische Betriebsmittel zur Verwendung innerhalb bestimmter Spannungsgrenzen (geändert durch 93/68/EWG)

Council Directive on the approximation of the laws of the Member States related to electrical equipment designed for use within certain voltage limits (amended by 93/68/EEC)

CE-Kennzeichnung / CE marking : 99

Die Konformität mit den Richtlinien wird nachgewiesen durch die Einhaltung folgender Normen:
 Conformity to the Directives is assured through the application of the following standards:

Referenznummer Reference number	Ausgabedatum Edition	Referenznummer Reference number	Ausgabedatum Edition
EN 61010-1	1993	EN 50082-2	1995
EN 50081-1	1992		

Ditzingen, den / the 22. Dezember 1999

Siemens AG

Pflugfelder, GL

Name, Funktion
Name, function



Unterschrift
signature

Veigel, GL

Name, Funktion
Name, function



Unterschrift
signature

Diese Erklärung bescheinigt die Übereinstimmung mit den genannten Richtlinien, ist jedoch keine Zusicherung von Eigenschaften.
 Die Sicherheitshinweise der mitgelieferten Produktdokumentation sind zu beachten.
 This declaration certifies the conformity to the specified directives but contains no assurance of properties. The safety documentation provided shall be considered in detail.

S

If you have any notes or questions on this product
please contact us under the following address:

Siemens AG
Power transmission und distribution,
Secondary systems
PO Box 4806
D-90026 Nuremberg

Phone +49 (0)180 524 7000

Order-No.:
Order location: G340B
Printed in Germany

Power
to the Point