

7XV5820 Industrial Modem and Modem-Router with Switch

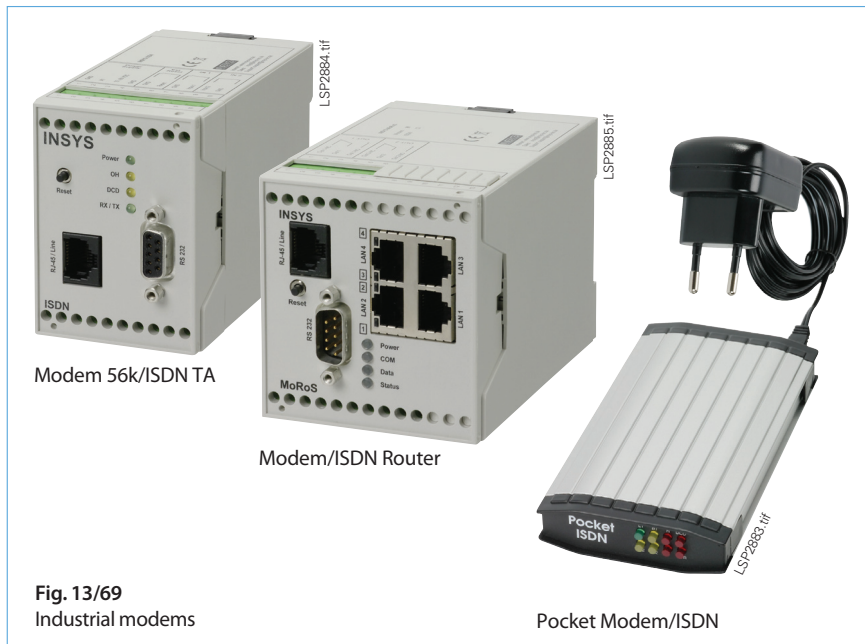

Fig. 13/69
Industrial modems

Pocket Modem/ISDN

Description

Depending on the available infrastructure and transmission requirements, various modems and routers are available for the remote communication with SIPROTEC protection devices using DIGSI.

The existing infrastructure may consist of analog or digital (ISDN) transmission networks, which may be private (internal telephone system) or a leased line. This may determine the corresponding combinations of the modems or routers. A suitable combination usually consists of a desktop device with plug adapter in the office, and a rail-mounted device in the substation (see Application). The rail-mounted devices may be operated with an optional wide-range power supply adapter with all alternating current networks as well as station batteries.

The desktop analog modem “Pocket 56k” as the office device and the rail-mounted “Modem 56k” in the substation ensure a secure serial data communication with SIPROTEC 3 devices using 8E1 (with parity bit) up to 19.2 kbit/s, or with SIPROTEC devices using 8N1 up to 57.6 kbit/s.

With the same analog modem “Pocket 56k” in the office it is possible to establish a connection to SIPROTEC 4 devices with EN100 interfaces in a local Ethernet network using the rail-mounted modem router “MoRoS Modem 56k” in the substation.

Using the digital modem “Pocket ISDN” as a desktop device in the office and the “ISDN TA” as a rail-mounted device in the substation ensures secure serial data communication with SIPROTEC 3 devices using 8E1 (with parity bit) up to 19.2 kbit/s, or with SIPROTEC 4 devices using 8N1 up to 57.6 kbit/s.

With the same digital modem “Pocket ISDN” in the office, it is also possible to communicate with SIPROTEC 4 devices with an EN100 interface module in a local Ethernet network using a rail-mounted ISDN router “MoRoS ISDN” in the substation.

Other combinations, especially with devices from other manufacturers are strictly not recommended.

All versions are suitable for application in control systems, and substations as well as in areas of energy supply and distribution. The modems can be deployed internationally (certificates of approval see “Technical Data”). As a rule, no certification is required for use in internal networks.

Application

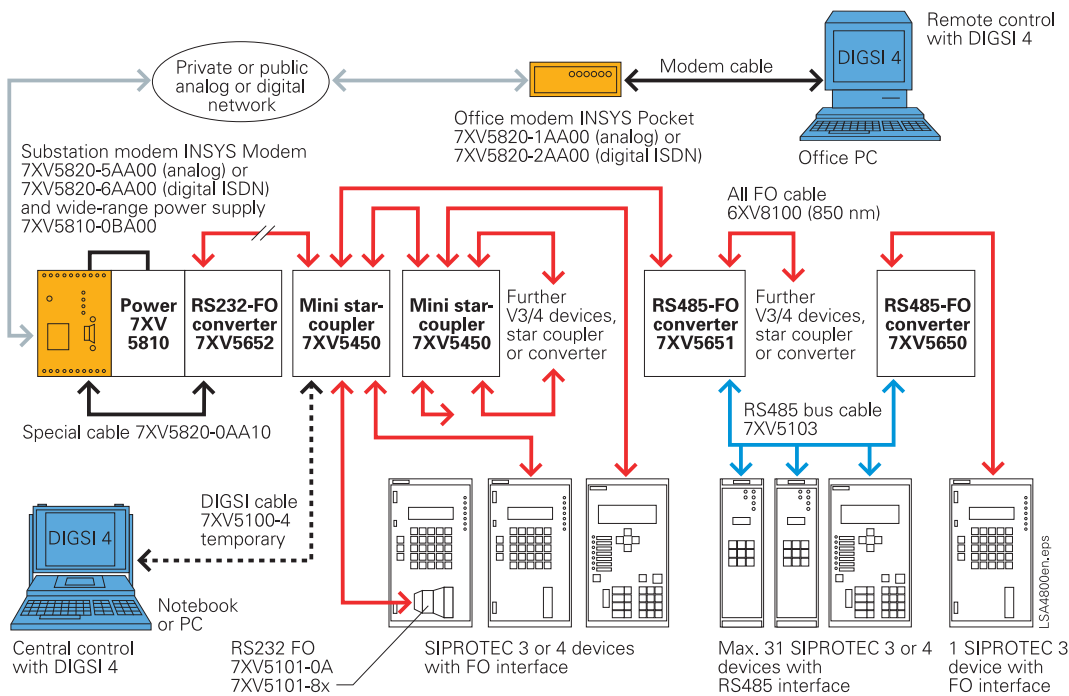

Fig. 13/70 Remote control of SIPROTEC 3 and 4 devices over INSYS Pocket to INSYS Modem, mini star-coupler or RS485 bus with DIGSI 4

Example 1: Remote operation of SIPROTEC 3 devices via modem

This application example illustrates remote operation of SIPROTEC 3 protection devices with an optical interface and compact protection devices with an RS485 interface using analog modems (7XV5820-1 and -5) or digital ISDN modems (7XV5820-2 and -6). Connection to protection or bay control RTUs via an optical interface is achieved with a star configuration using cascable star couplers. The compact protection devices with RS485 interface are connected via a FO-RS485 converter and the RS485 bus system 7XV5103. SIPROTEC 4 devices may be connected optically or electrically, depending on the available service interface.

To ensure secure lightning protection, galvanic separation between the substation modem and the protection devices must be implemented by means of an optical barrier. The substation modem with the 7XV5652 RS232-FO converter is preferably located in a communication or control room while the 7XV5450 star coupler or 7XV5650/51 FO-RS485 converter is located in the first protection cubicle. If the protection devices are to be controlled centrally in the substation using a notebook, this is achieved by plugging a DIGSI cable into the first star coupler, which disables the optical interface and enables the RS232 connection.

Communication with the modems is transparent. Secure data transfer to the SIPROTEC 3 devices is achieved with the data format 8E1 (with parity bit). The data transmission rate depends on the slowest device (9.6 kbit/s or 19.2 kbit/s) and must be set to be equal for all devices. The SIPROTEC 4 devices can then only be operated with this data rate which is relatively slow for SIPROTEC 4.

Application

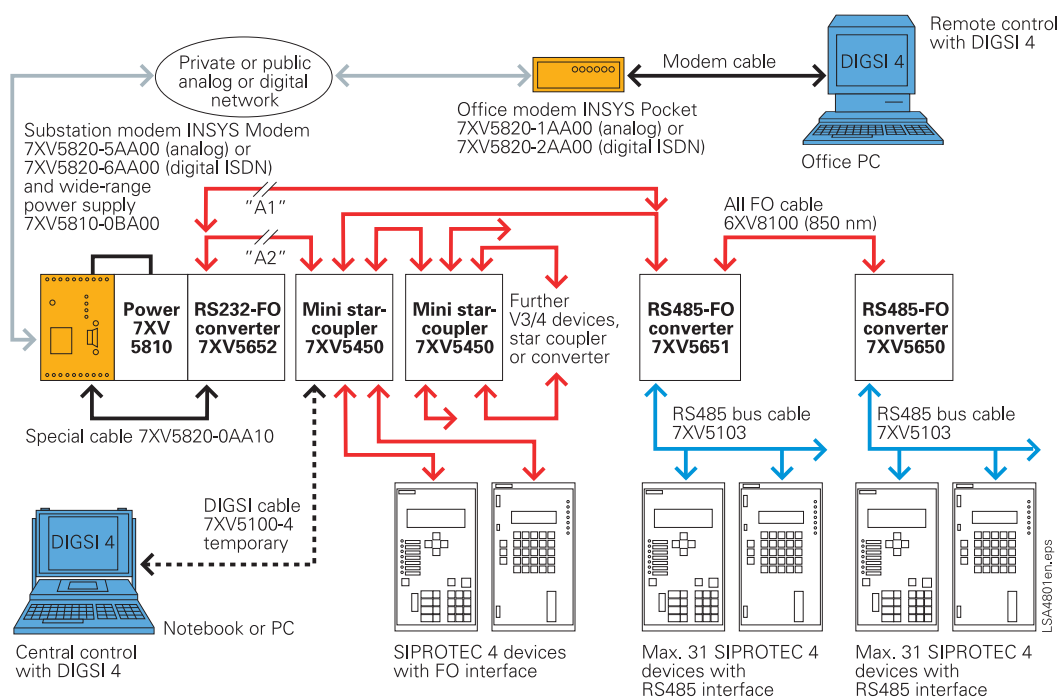

Fig. 13/71 Remote control of SIPROTEC 4 devices over INSYS Pocket to INSYS Modem, mini star-coupler or RS485 bus with DIGSI 4

Example 2: Remote operation of SIPROTEC 4 devices via modem

This application example illustrates remote operation of SIPROTEC 4 devices with an optical or RS485 interface via analog modems (7XV5820-1 and -5) or the very much faster digital ISDN modems (7XV5820-2 and -6). Connection of the protection or RTU devices with optical interface is achieved via cascable star couplers. The devices with RS485 interfaces are connected via the FO-RS485 converter and the RS485 bus system 7XV5103.

To ensure secure lightning protection of the RS485 bus, galvanic separation should always be implemented between the substation modem and the protection devices by means of an optical barrier. The substation modem with the RS232-FO converter 7XV5652 is preferably located in a communication or control room while the first FO-RS485 converter 7XV5651/50 is located in the first protection cubicle ("A1").

If the protection devices are to be centrally controlled in the substation, an additional star coupler must be used ("A2"). By plugging the DIGSI cable into the first star coupler, the optical interface is disabled and the RS232 connection is established. If no mini star coupler is used, central operation is only possible via the electrical interface of the RS232-FO converter. The modem plug must be disconnected for this purpose.

A secure communication via the modems is possible with the standard data format 8N1, with data compression and error correction. The data transmission rate is determined by the slowest device (38.4 kbit/s or 57.6 kbit/s) and must be set to be the same on all devices.

Application

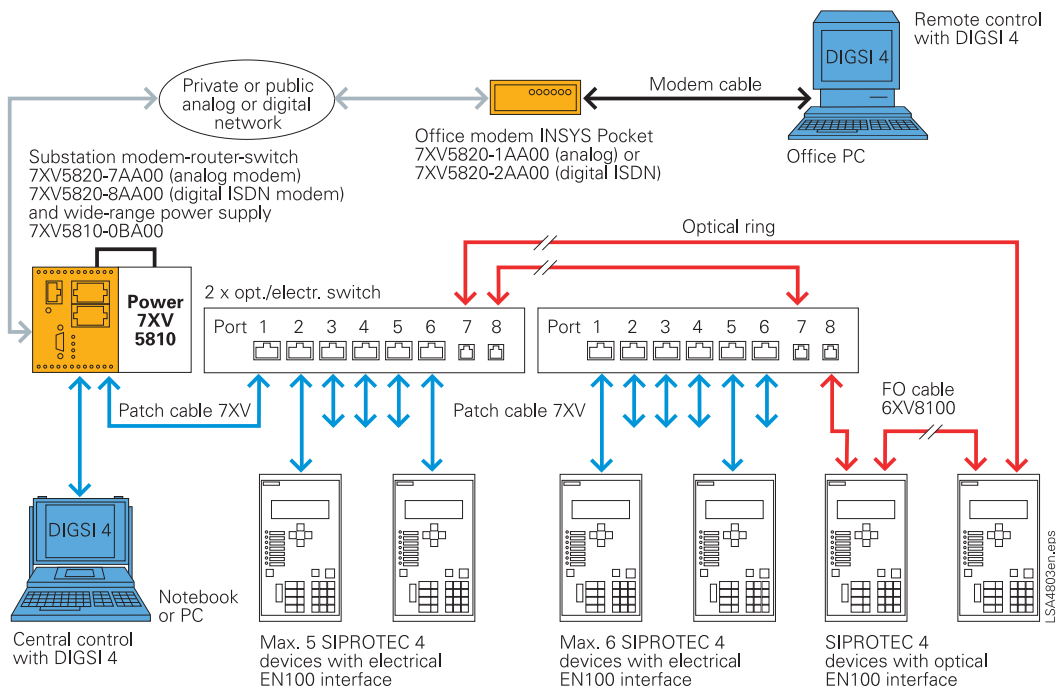

Fig. 13/72 Remote control of SIPROTEC 4 devices with EN100 Ethernet module with DIGSI 4 over INSYS Pocket Modem/ISDN to INSYS Modem/ISDN router with switch and external optical/electrical Switch

Example 3: Remote operation of SIPROTEC 4 devices with Ethernet interfaces via a modem-router

This application example shows remote operation of SIPROTEC 4 protection devices with an optical or electrical EN100 Ethernet interface via an analog or digital ISDN office modem, (7XV5820-1 or -2), to a modem or digital ISDN router (7XV5820-7 and -8). This router with an integrated 4-way switch together with the RUGGETCOM switches connected via a patch cable form a local subnet.

The protection or RTU devices with optical EN100 interface are connected to the RUGGETCOM switches in a ring structure. The protection / RTU devices with an electrical EN100 interface are directly connected to the modem-router and switch or to the electrical interfaces of the RUGGETCOM switches by means of double-shielded patch cables. To minimize any possible interference, the electrical connections with patch cables should be kept as short as possible.

Remote connection from the office to the substation is established by means of a password-protected DUN connection under Windows. The connection is then "transparent" and the protection devices can be operated with DIGSI 4 in the local subnet with their own IP addresses.

If the protection devices are to be conveniently centrally controlled using a notebook in the substation, the notebook with an Ethernet interface can be logged into the local subnet with a patch cable.

Secure communication via modems is performed at 57.6 kbit/s, with standard data format 8N1 with data compression and error correction.

7XV5810-1AA00 and 7XV5820-2AA00 INSYS Pocket Modem

Description

Data communication in the private, commercial and industrial applications is becoming ever more important.

INSYS Pocket Modem 56k and INSYS Pocket ISDN TA fascinate with their sophisticated engineering and their shapely compact metal housing.

The devices are ideal as remote stations for our DIN rail series.



Fig. 13/73 7XV5810/7XV5820 pocket modem

Technical Data

Modem	7XV5820-1AA00	7XV5820-2AA00
Network interface, line requirement	Analog telephone network	ISDN net, S0/I.430 Euro ISDN DSS1
Data transmission rate	Up to 56 kbits/s	64 kbit/s
Software update	Flash	Flash
Approvals	R & TTE, CTR21	R & TTE, CTR3
Application	For international use	Europe
Standards	Developed according to CE directives, manufactured according to ISO 9002	Developed according to CE directives, manufactured according to ISO 9002
Features		
Configuration	Remote configuration, AT commands	Local, via PC terminal, remote via ISDN
Connection	Auto answer mode, hardware-handshake Speed adjustable, sleep mode, auto-bauding, display caller ID	Auto answer mode with optional phone number verification
Data format	10 and 11 bit: 7E1, 7O1, 7N2, 7E2, 7O2, 8N1, 8E1, 8O1, 8N2	B channel: V.110, X.75, V.120, X.25/X.31, HDLC (PPP), T70NL, T90NL D channel: 1TR6 DSS1, VNx
Protocols	V.92, V.90, V.34+, V.34, V.32bis, V.32, V.23, V.22bis, V.22, V.21, Bell Norm 103/212, Fax class 1/2	–
Compression	MNP5, V.42 bis, MNP 10, 10 EC, V.44	–
Error correction	MNP 2/3/4 and V.42	–
Security functions	Security call-back, alarm transmission, SMS to fixed network or as fax over AT command, selective call answer, line-in-use detection, selectable key-abort	Access protection via approved phone number (accessible), password protection of remote configuration
Electrical features		
Power supply	9 ... 10 V DC (with plug power supply 230 V AC)	5 V DC (with plug power supply 100 to 230 V AC)
Consumption	Approx. 140 mA DC	Max. 100 mA at 5 V/500 mW
Interface to application	RS232, 9-pin SUB-D jack	RS232, 9-pin SUB-D jack
Interface to network	RJ-12 (Western)	RJ-45 connector
Physical features		
Size in mm (w x d x h)	71 x 128 x 22	71 x 128 x 22
Temperature range	0 to 55 °C	0 to 55 °C
Humidity	0 to 95 % (non-condensing)	0 to 95 % (non-condensing)



Fig. 13/74 7XV5820 modem

7XV5820 INSYS Modem 56k Profi 7XV5820 INSYS ISDN TA Profi

Description

With the INSYS Modem 56k Profi any application can be connected to the analog telephone network, which is available worldwide. The INSYS ISDN 4.0 can easily be connected to the digital ISDN network.

Both modems enhance pure data communication with alarming and security functions: alarms with a user-defined text as an SMS, fax or e-mail are triggered by digital inputs. Data connections (INSYS Modem 56k) and remote control are protected by passwords. The INSYS 56k modem establishes a connection only to a predefined number in response to an incoming call if the security call-back is activated. Selective call answer allows only data calls from specified numbers.

The digital outputs can be controlled remotely. The INSYS 56k modem controls these outputs by data connection as well as by DTMF tones from a tone dial phone. The digital outputs can be configured to display the connections status.

Technical data

Modem	7XV5820-5AA00	7XV5820-6AA00
Network interface	2-wire leased or dial-up line	S0/1.430 Euro ISDN network, DSS1
Data transmission rate	Max. 56 kbit/s	Max. 68 kbit/s (channel building 128 kbit/s)
Digital in-/outputs	2 alarm inputs/2 control outputs	
Watchdog	Yes	—
Software update	—	Flash update
Approvals	—	R & TTE, CTR3
Application	—	Europe
Standards	—	Developed according to CE directives
Features		
Configuration	AT commands via serial line, remote configuration	AT commands, configuration over serial line, remote configuration, CAPI
Connection	Auto-answer mode, idle connection ctrl, auto-bauding, number storage, hard-/software handshake	
Alarm functions	International settings, caller ID presentation, SMS to fixed-line telephone network, fixed serial speed, sleep mode	
Output control	AT command (local & remote) DTMF	AT command, configurator, connection status
Security functions	Password protection for connection, remote control and security callback	
Data formats	10 and 11 bit: 7E1, 7O1, 7N2, 7E2, 7O2, 8N1, 8E1, 8O1, 8N2	Number identification (CLIP)
Protocols, error correction, compression	Bit transparent V.32bis, V.32, V.23, V.22, V.22bis, V.21, V.34+, V.90, V.92, Bell Norm 103/212, Fax Class ½, MNP 2/3/4, V.42, MNP 10, MNP 10 EC, MNP 5 V.42bis	B channel: X.75, X.25/X.31, HDLC/PPP, V.110, V.120 asynchronous; D channel: X.31
Electrical features		
Supply voltage	10 to 60 V DC	10 to 60 V DC
Current consumption	Transmission: 200 mA (at 12 V) Standby: 160 mA (at 12 V)	40 mA
Inuts/outputs	SPDT (single-pole double-throw) switches by galvanically isolated relays, max. voltage 30 V DC/42 V AC, max. current: 1 A DC/0.5 A AC	
Serial line speed	300 bit/s to 115.2 kbit/s	1.2 to 230.4 kbit/s
Physical features		
Housing size	55 x 110 x 75 (w x d x h) in mm	
Ambient temperature	0 to 55 °C	0 to 70 °C
Humidity	0 to 95 % (non-condensing)	0 to 90 % (non-condensing)

7XV5820-7/-8AA00 Modem-Router-Switch (MoRoS)

Description

Modem-Router-Switch by INSYS combines a modem, a router and a 4-port switch. The dial-in and dial-out functionality enables remote maintenance and operation of devices in an Ethernet network.

The MoRoS device is available with an integrated analog modem or with ISDN-TA. The integrated 4-port switch allows for direct connection of up to four network devices. The MoRoS device has an international 56k modem for global application. The configuration of the MoRoS device is easy and fast via a web interface.

MoRoS by INSYS is a device that combines modem, router and switch functions for the remote maintenance of Ethernet-enabled products, e.g. PLC, HMI, etc.

Function overview

- Integrated communication module (analog modem or ISDN-TA)
- Dial-in
- Dial-out (dial-on-demand)
- 4-port switch with 10/100 Mb/s
- DHCP server and client
- Integrated configuration interface with help function
- Authentication for up to 10 users (dial-in)
- Dialing filter for dial-out
- Authentication via PAP, CHAP, MS-CHAP, MS-CHAP 2
- Easy configuration
- Local or remote configuration
- Firmware update (local and remote)
- 2 digital inputs and outputs
- Buffered RTC (real time clock)
- Full NAT
- DNS relay
- Serial Ethernet Server ¹⁾
- VPN ¹⁾
- Firewall ¹⁾

¹⁾ version MoRoS PRO only

Technical data

Modem	7XV5820-7/-8AA00 MoRoS
Certifications	R & TTE, CTR2 (dial-up line), CTR3 (ISDN), CE
Dial-up line	Transmission rate 56 kbits/s
ISDN	Transmission rate 64 kbits/s
Configuration	Web interface, AT command (via web interface), local and remote



Fig. 13/75 7XV5820 Modem-Router-Switch (MoRoS)

Router	
Function	Dial-in, dial-out
Authentication	10 users for dial-in, authentication via PAP, CHAP, MS-CHAP, MS-CHAP 2
Dialing filter (dial-out)	Filtering of IP addresses and/or ports
Configuration	Web interface, AT command (via web interface), local and remote
DHCP server and client	
Watchdog (ext. hardware watchdog)	
RTC (buffered real time clock)	
Full NAT	
VPN ¹⁾	
Firewall ¹⁾	
Serial Ethernet server ¹⁾	
Switch	
Ports	4
Operating mode	10/100 Mb/s for full and half duplex operation
Auto detect	Automatically recognizes patch and cross-over cables; automatic speed adjustment
Configuration	
Web interface	Local/remote
Additional features	Digital inputs and outputs, firmware update local/remote
Supply	
Voltage	10 V to 60 V DC
Power input	Approx. 2.5 W (during connection)
Physical features	
Housing size	70 x 110 x 75 mm
Operating temperature	0 to 55 °C
Humidity	0 to 95 % (non-condensing)
Weight	10.58 oz

Selection and ordering data

Description	Order No.
<i>7XV5820 modem/modem-router</i>	<i>7XV5820-□AA00</i>
<i>Analog Pocket Modem 56k</i> Desktop device, with plug-in power supply 230 V AC	1
<i>Digital Pocket Modem ISDN 64k</i> Desktop device, with plug-in power supply 100 to 230 V AC	2
<i>Analog Modem 56k</i> for DIN rail-mounting, power supply 10 to 60 V DC	5
<i>Digital Modem ISDN 64k</i> for DIN rail-mounting, power supply 10 to 60 V DC	6
<i>Analog Modem-Router</i> with 4-way switch for DIN rail-mounting, power supply 10 to 60 V DC	7
<i>Digital ISDN Router</i> with 4-way switch for rail-mounting 10 to 60 V DC	8
<i>Modem/Modem-Router Accessories</i>	<i>7XV5820-0AA10</i>
Data cable from modem to 7XV5300, 7XV5450, 7XV5550, 7XV5652 2 x SUB-D connector, 9-pin female, length 2 m	