

7XV5850/5851 Ethernet Modems for Office Applications



Fig. 15/71
7XV585x Ethernet modem

Function overview

- DIGSI supports the administration and the setting-up of connections via the Ethernet network.
- RS232 interfaces for data transfer and configuration of the modem.
- Serial baud rate and data format (RS232) for the terminal devices is selectable from 2400 Bd up to 57.6 kBd with data format 8N1, 8E1.
- An Ethernet interface LAN to the 10/100 Mbit network.
- Better security with password protection and IP address selection is possible.

Description

A control PC and protection units can exchange serial data via an Ethernet network using two Ethernet modems 7XV585x. Connection to the Ethernet modem is in each case made via the asynchronous serial interface of the terminal units. In the modem, the serial data is packed into the secure IP protocol as information data, and is transferred between the modems using the Ethernet connection. Conformity with the standard and gap-free transmission of serial DIGSI or IEC 60870-5-103/101 telegrams via the network is ensured by the modem which receives the serial telegram communication and packs the serial IEC telegrams into blocks for communication via the Ethernet. The data is transmitted in full duplex mode; serial control wires are not supported. Connection is established between the IP address of the dialing modem in the office and the IP address of the pick-up modem in the substation, and is configured prior to dialing up with DIGSI by means of AT commands via the RS232 interface.

The substation modem may be configured to have password protection, and provides the additional security feature, whereby access is only permitted from defined IP addresses, e.g. only that of the office modem. The modem is accessed with DIGSI Remote like a normal telephone modem with the exception that instead of telephone numbers, IP addresses are assigned by the network administrator for each modem.

Application

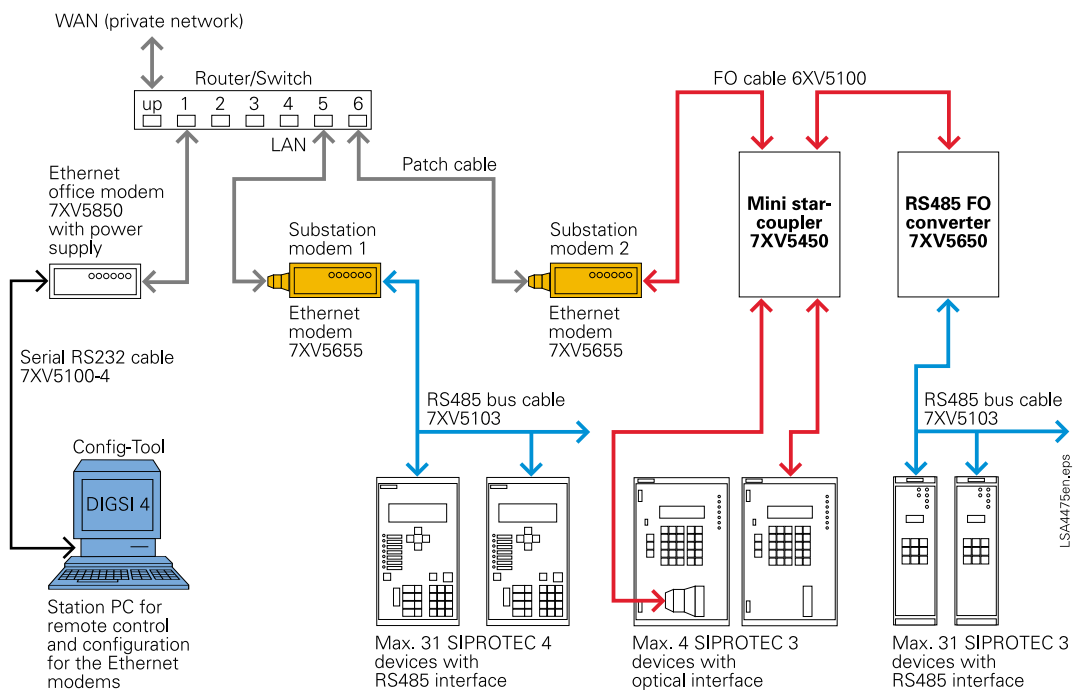

Fig. 15/72 Operation of various SIPROTEC protection unit generations via Ethernet modems

Using the office computer and DIGSI 4, both substation 1 and 2 may be dialed up via Ethernet modems. A TCP/IP point-to-point data connection is established between the office modem and corresponding substation modem when dialed up via the network. This is maintained until the office modem terminates the connection. The serial data exchange takes place via this data connection, with the modem converting the data from serial to Ethernet with full duplex mode. Between the office modem and the office PC, the highest baud rate is always used, e.g. 57.6 kB for SIPROTEC 4 units. The serial baud rate of the substation modem is adapted to the baud rate required by the protection relays, e.g. substation modem 1 with 57.6 kB for SIPROTEC 4 and substation modem 2 with 9.6 kB for SIPROTEC 3 units. These settings are only defined once in the modem. The Ethernet modems are integrated in DIGSI 4 similar to telephone modems. Instead of the telephone number, the pre-set IP address assigned to the modem is selected.

If later an Ethernet connection is available in the substation, the existing modem can be replaced by an Ethernet modem. The entire serial bus structure and cabling may remain unchanged.

Technical data

Connections

RS232 interface 9-pin, SUB-D connector
 Ethernet 10BaseT, 10/100 Mbit, RJ45
 Power supply (see below)

Desktop device for office use 7XV5850-0AA00

Housing Desktop housing, plastic, charcoal grey, 46 x 109 x 74 (W x H x D) in mm
 Supply Wide-range plug-in power supply, auxiliary voltage 100 - 240 V AC
 Scope of supply With RS232 cable for Notebook/PC. With Ethernet cable (cross-over) 2 m

Modem for rail mounting 7XV5851-0AA00

Housing Rail mounting, plastic, charcoal grey, 46 x 109 x 74 (W x H x D) in mm
 Supply Auxiliary voltage 18 - 24 V DC (screw-type terminal), expandable with 7XV5810-0BA00
 Scope of supply With RS232 cable to SIPROTEC 4, 7XV5300, 7XV5550, 7XV5652.
 With Ethernet cable (cross-over) 2 m for configuration

Indication (8 x LED)

Power	Operating voltage o.k.
RS232 TxD	Transmitting data to RS232
LAN Tx	Transmitting data to LAN
Error	Error on RS232
System	RS232 connection established
RS232 RxD	Receiving data from RS232
LAN Rx	Receiving data from LAN
Link LAN	LAN connection established

Selection and ordering data

Description	Order No.	
Ethernet Modem	7XV585□ - 0AA00	
Ethernet modem for serial, asynchronous transmission of data up to 57.6 kbit via the 10/100 Mbit Ethernet and configuration software	↑	
Desktop device (office version) Connection to Ethernet via RJ45 connector, serial connection SUB-D 9-pin socket including wide-range power supply 100/240 V AC With cross-over Ethernet patch cable 2 m for configuration With serial connection cable to PC 2 m		0
EN 50022 rail device (preferred as substation modem) Connection to Ethernet via RJ45 connector, serial connection SUB-D 9-pin socket Auxiliary supply 18 - 24 V DC (other voltages with 7XV5810-0BA00) including cross-over Ethernet patch cable 2 m and serial connection cable to SIPROTEC 4, 7XV5300, 7XV5450, 7XV5550, 7XV5652 2 m		1

