

## 400 kV Overhead Transmission Line Protection

### 1. Introduction

This application example will guide the reader through all the steps required to set the distance protection functions for a typical transmission line. Standard supplements such as teleprotection, power swing, switch onto fault, directional earth-fault protection, etc. are also covered.

### 2. Key functions applied:

- Distance protection (ANSI 21):  
Quadrilateral characteristic
- Teleprotection for ANSI 21:  
POTT
- Earth fault O/C (ANSI 67N):  
IEC curves, directional
- Teleprotection for ANSI 67N:  
Directional comparison
- Power swing blocking
- Weak infeed:  
Echo and trip
- Overcurrent protection:  
Emergency mode
- Auto-reclose:  
1 and 3-pole, 1 cycle
- Synchronism check:  
Sync. and async. closing
- Fault locator:  
Single-end measurement

### 3. Single line diagram and power system data

The required time graded distance protection zones are:



Fig. 1 Universal protection for OHL

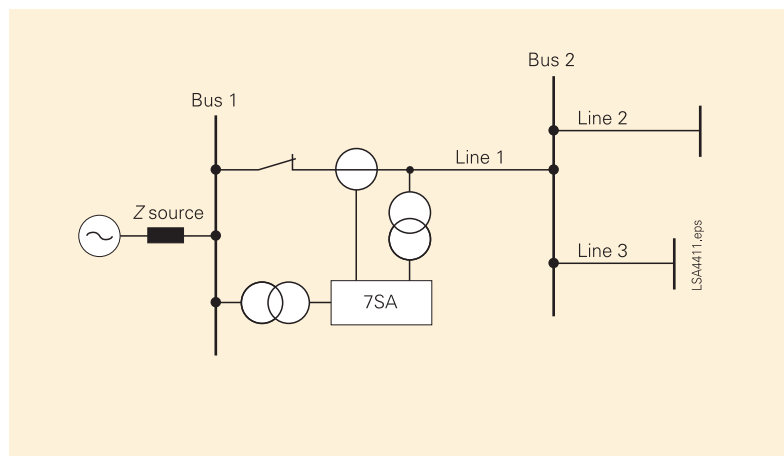

Fig. 2 Single line diagram of protected feeder

Zone number	Function	Reach	Time delay
Zone 1	Fast underreach protection for Line 1	80 % Line 1	0 s
Zone 2	Forward time delay backup, overreach	20 % less than Z1 reach on Line 3	1 time step
Zone 3	Reverse time delay backup	50 % Z-Line 1	2 time steps
Zone 4	Not applied	–	–
Zone 5	Non-directional	120 % Line 2	3 time steps

Table 1 Notes on setting the distance protection zones

	Parameter	Value
System data	Nominal system voltage phase-phase	400 kV
	Power system frequency	50 Hz
	Maximum positive sequence source impedance	10 + j100
	Maximum zero sequence source impedance	25 + j200
	Minimum positive sequence source impedance	1 + j10
	Minimum zero sequence source impedance	2.5 + j20
	Maximum ratio: Remote infeed / local infeed ( $I_2/I_1$ )	3
Instrument transformers	Voltage transformer ratio (LINE)	380 kV / 100 V
	Voltage transformer ratio (BUS)	400 kV / 110 V
	Current transformer ratio	1000 A / 1 A
	Current transformer data	5P20 20 VA $P_1 = 3$ VA
	CT secondary connection cable	2.5 mm <sup>2</sup> 50 m
	CT ratio / VT ratio for impedance conversion	0.2632
Line data	Line 1 – length	80 km
	Maximum load current	250 % of full load
	Minimum operating voltage	85 % nominal voltage
	Sign convention for power flow	Export = negative
	Full load apparent power (S)	600 MVA
	Line 1 – positive seq. impedance per km $Z_1$	0.025 + j0.21 $\Omega$ /km
	Line 1 – zero seq. impedance per km $Z_0$	0.13 + j0.81 $\Omega$ /km
	Line 2 – total positive seq. impedance	3.5 + j39.5 $\Omega$
	Line 2 – total zero seq. impedance	6.8 + j148 $\Omega$
	Line 3 – total positive seq. impedance	1.5 + j17.5 $\Omega$
	Line 3 – total zero seq. impedance	7.5 + j86.5 $\Omega$
	Maximum fault resistance, Ph - E	250 $\Omega$
	Power data	Average tower footing resistance
Earth wire		60 mm <sup>2</sup> steel
Distance: Conductor to tower/ground (midspan)		3 m
Distance: Conductor to conductor (phase-phase)		5 m
Circuit-breaker	Trip operating time	60 ms
	Close operating time	70 ms

**Table 2** Power system and line parameters

Based on the source and line impedance, the following minimum fault current levels can be calculated for faults on Line 1:

$$I_{\text{fault}} = \frac{U_{\text{source}}}{\sqrt{3} \cdot Z_{\text{tot}}} \quad \text{with} \quad U_{\text{source}} = 400 \text{ kV}$$

If fault resistance is neglected then for 3-phase faults:

$Z_{\text{tot}}$  = sum of positive sequence source and line impedance (as only current magnitudes are being calculated, only the magnitude of the impedance is relevant)

$$|Z_{\text{tot}}| = |(10 + 80 \cdot 0.025) + j(100 + 80 \cdot 0.21)|$$

$$|Z_{\text{tot}}| = |12 + j116.8|$$

$$|Z_{\text{tot}}| = 117.4$$

The minimum three-phase fault current is therefore:

$$I_{3_{\text{ph min}}} = \frac{400 \text{ kV}}{\sqrt{3} \cdot 117.4}$$

$$I_{3_{\text{ph min}}} = 1967 \text{ A}$$

If fault resistance is neglected then for single-phase faults:

$Z_{tot} = 1/3$  (sum of positive, negative and zero sequence source and line impedance)

$$|Z_{tot}| = \frac{|2 \cdot [(10 + 80 \cdot 0.025) + j(100 + 80 \cdot 0.21)] + (25 + 80 \cdot 0.13) + j(200 + 80 \cdot 0.81)|}{3}$$

$$|Z_{tot}| = |19.8 + j166.1|$$

$$|Z_{tot}| = 167.3$$

The minimum single-phase fault current without fault resistance is therefore:

$$I_{ph \min} = \frac{400 \text{ kV}}{\sqrt{3} \cdot 167.3} = 1380 \text{ A}$$

If fault resistance is included then for single-phase faults:

$$Z_{tot\_R} = Z_{tot} + R_F$$

$$|Z_{tot\_R}| = |R_F + Z_{tot}|$$

$$|Z_{tot}| = |250 + 19.8 + j166.1|$$

$$|Z_{tot}| = 316.8$$

The minimum single-phase fault current with high resistance is therefore:

$$I_{ph \min\_R} = \frac{400 \text{ kV}}{\sqrt{3} \cdot 316.8} = 729 \text{ A}$$

#### ■ 4. Selection of device configuration (functional scope)

After selection and opening of the device in the DIGSI Manager, the first step when applying the settings is entering the functional scope of the device. A sample screen shot showing the selection for this example is given below:

No.	Function	Scope
0103	Setting Group Change Option	Disabled
0110	Trip mode	1-/3pole
0112	Phase Distance	Quadrilateral
0113	Earth Distance	Quadrilateral
0120	Power Swing detection	Enabled
0121	Teleprotection for Distance prot.	POTT
0122	DTT Direct Transfer Trip	Disabled
0124	Instantaneous HighSpeed SOTF Overcurrent	Disabled
0125	Weak Infeed (Trip and/or Echo)	Enabled
0126	Backup overcurrent	Time Overcurrent Curve IEC
0131	Earth fault overcurrent	Time Overcurrent Curve IEC
0132	Teleprotection for Earth fault overcurr.	Directional Comparison Pickup
0133	Auto-Reclose Function	1 AR-cycle
0134	Auto-Reclose control mode	with Trip and Action time
0135	Synchronism and Voltage Check	Enabled
0138	Fault Locator	Enabled
0140	Trip Circuit Supervision	Disabled

Fig. 3 Selected scope of functions

The available functions displayed depend on the ordering code of the device (MLFB). The selection made here will affect the setting options during the later stages. Careful consideration is therefore

required to make sure that all the required functions are selected and that the functions that are not required in this particular application are disabled. This will ensure that only relevant setting alternatives appear later on.

#### 103 Setting Group Change Option:

Only enable this function, if more than one setting group is required. In this example only one setting group is used; therefore this function is **disabled**.

#### 110 Trip mode:

On OHL applications, single-pole tripping is possible if the circuit-breaker is capable of this. The advantage is that during a single-pole dead time the OHL can still transport some power and reduce the risk of system instability. In this example both one and three-pole tripping is used so the setting is **1-/3-pole**.

#### 112 Phase Distance:

As distance protection for phase faults is required, **Quadrilateral** must be selected. In some cases (depending on the ordering code) a **MHO characteristic** can also be selected.

#### 113 Earth Distance:

Here the earth fault distance protection characteristic is selected as for 112 above. Therefore set **Quadrilateral**.

#### 120 Power Swing detection:

If power swing conditions can occur in the vicinity of the applied relay, the power swing detection must be enabled. It is required for blocking of the distance protection during power swings. At 380 kV it is common practice to **Enable** the power swing detection.

#### 121 Teleprotection for Distance prot.:

To achieve fast tripping for all faults on the circuit a teleprotection scheme must be applied.

Parameter	PUTT	POTT	Blocking	Unblocking
Short line	Not suitable as the Zone 1 operation is essential and Zone 1 setting in X and R direction must be small on short lines	Suitable as the Z1b setting may be substantially larger than the line impedance so that signal transmission is secure for all faults on the line	Suitable as reverse reach setting is independent of line length	Suitable as the Z1b setting may be substantially larger than the line impedance so that signal transmission is secure for all faults on the line
Weak infeed	Not suitable as the Zone 1 operation is essential at both ends for 100 % line coverage	Suitable as the strong end detects all line faults with overreaching Z1b. The weak infeed end then echos the received signal	Partially suitable as the reverse fault is also detected at the weak infeed end but no trip at weak infeed end	Suitable as the strong end detects all line faults with overreaching Z1b. The weak infeed end then echos the received signal
Amplitude modulated power line carrier	Not suitable as the signal must be transmitted through the fault location which attenuates the signal	Not suitable as the signal must be transmitted through the fault location which attenuates the signal	Suitable as the signal is only sent when the line is not faulted	Not suitable as the signal must be transmitted through the fault location which attenuates the signal
Frequency or phase modulated power line carrier	Suitable as the signal can be transmitted through the fault location	Suitable as the signal can be transmitted through the fault location	Suitable as the signal can be transmitted under all conditions	Suitable as the signal can be transmitted through the fault location
Communication independent of power line	Suitable	Suitable	Suitable	Suitable

**Table 3** Selection of teleprotection scheme

In this case the selection is **POTT**

122 DTT Direct Transfer Trip:

If external inputs must be connected to initiate tripping via binary input, this function should be activated. The trip will then automatically be accompanied by the minimum trip command duration (trip circuit seal in) and event and fault recordings. In this example this function is not required and therefore **Disabled**.

124 Instantaneous High Speed SOTF Overcurrent:

When closing onto bolted faults extremely large currents arise that must be switched off as fast as possible. A special overcurrent protection stage is provided for this purpose. In this example it will not be used and is therefore **Disabled**.

125 Weak Infeed:

When weak infeed conditions exist (permanently or temporarily) at one or both ends, the weak infeed function must be **Enabled**. Refer also to Table 3.

126 Backup overcurrent:

When the distance protection is in service, it provides adequate backup protection for remote failures. The overcurrent protection in the distance relay is usually only applied when the distance function is blocked due to, for example, failure of the measured voltage circuit (VT-fuse fail). This will be done in this example, so the function must be activated. The selection of the response curve

standard is **Time Overcurrent Curve IEC** in this application.

131 Earth Fault overcurrent:

For high resistance earth faults it is advisable to not only depend on the distance protection as this would demand very large reach settings in the R direction. The directional (and non-directional) earth-fault protection is very sensitive to high resistance earth faults and is therefore activated in this example. Here **Time Overcurrent Curve IEC** is selected.

132 Teleprotection for Earth fault Overcurr.:

To accelerate the tripping of the earth-fault protection (activated under 131 above) a teleprotection scheme can be applied. In this example a **Directional Comparison Pickup** scheme will be applied.

133 Auto-Reclose Function:

Most faults on overhead lines are of a transient nature so that the line can be energised successfully after fault clearance. For this purpose an automatic reclosure function can be implemented to minimise the line outage by reclosing with a set or flexible dead time. In this application **1 AR-cycle** will be applied.

## 134 Auto-Reclose control mode:

If, as in this example, single and three-pole tripping is used, the auto-reclose function is triggered by the trip command. If the trip is due to a backup protection operation (e.g. Zone 2) then reclosure is normally not desired. By application of an action time which monitors the time between fault detection and trip, reclosure can be prevented for time delayed tripping (longer than set action time). In this example the auto-recloser will be triggered with **Trip and Action time monitoring**.

## 135 Synchronism and Voltage Check:

Before closing a circuit-breaker it is advisable to check that the system conditions on both sides of the circuit-breaker are suitable for being connected. For this purpose the Synchronism and Voltage Check function is **Enabled** in this example.

## 138 Fault Locator:

Following fault clearance an inspection of the fault location may be needed to check that there is no permanent damage or risk of further faults at the fault location. Particularly on longer lines it is very helpful to have an indication of the fault location to allow faster access by the inspection team. For this purpose the fault locator is **Enabled** in this example.

## 140 Trip Circuit Supervision:

The monitoring done by the relay can be extended to include the trip circuit and trip coils. For this purpose a small current is circulated in the monitored circuits and routed via binary inputs to indicate a failure. In this example this function is not used and therefore set to **Disabled**.

### ■ 5. Masking I/O (configuration matrix)

The configuration matrix is used to route and allocate the information flow in the device. All the assignments of binary inputs and outputs, as well as LED's, sequence of event records, user defined logic, controls etc. are made in the matrix.

### ■ 6. User defined logic CFC

If any special logic is required in the application, the CFC task can be used for this purpose.

### ■ 7. Settings for power system data 1

#### 7.1 Instrument transformers

Under this heading power system parameters are applied. Place a 'Tick' in the box 'Display additional settings' to include 'advanced' settings (designated by A, e.g. 0214A) in the displayed list.

The 'advanced' settings can in most cases be left on the default setting value.

No.	Settings	Value
0201	CT Starpoint	towards Line
0203	Rated Primary Voltage	380,0 kV
0204	Rated Secondary Voltage (L-L)	100 V
0205	CT Rated Primary Current	1000 A
0206	CT Rated Secondary Current	1 A
0210	U4 voltage transformer is	Usync transformer
0211	Matching ratio Phase-VT To Open-Delta-VT	1,73
0212	VT connection for sync. voltage	L3-L1
0214A	Angle adjustment Usync-Uline	0 °
0215	Matching ratio U-line / Usync	1,05
0220	I4 current transformer is	Neutral Current (of the protected line)
0221	Matching ratio I4/Iph for CT's	1,000

Display additional settings

Fig. 4 Configuration of CT and VT circuits

## 201 CT Starpoint:

In this application the CTs are connected as shown below in Figure 5. The polarity of the CT connection must be selected correctly to ensure correct response by the protection. For this purpose the position of the starpoint

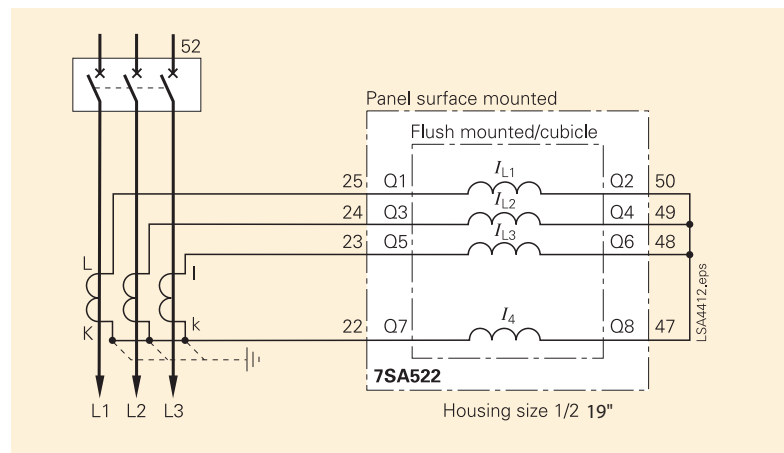

Fig. 5 Relay connections

connection is indicated: In this example it must be set **towards line**.

## 203 Rated Primary Voltage:

The VT ratio must be set correctly to ensure accurate measured value output. It is also possible to set the protection parameters in primary quantities. For correct conversion from primary to secondary the VT and CT data must be set correctly. In this application the VT primary voltage is 380 kV.

## 204 Rated Secondary Voltage (ph-ph):

Set to 100 V as per VT data.

## 205 CT Rated Primary Current:

Set to 1000 A as per CT data.



- 206 CT Rated Secondary Current:  
Set to 1 A as per CT data. Note that this setting must correspond to the jumper settings on the measurement module (printed circuit board). If this is not the case, the relay will block and issue an alarm. Refer to device manual for instructions on changing jumper settings.
- 210 U4 voltage transformer is:  
The 4th voltage measuring input may be used for a number of different functions. In this example it is connected to measure busbar voltage for synchronising check (set **U<sub>sync</sub> transformer**) as shown in Figure 6.

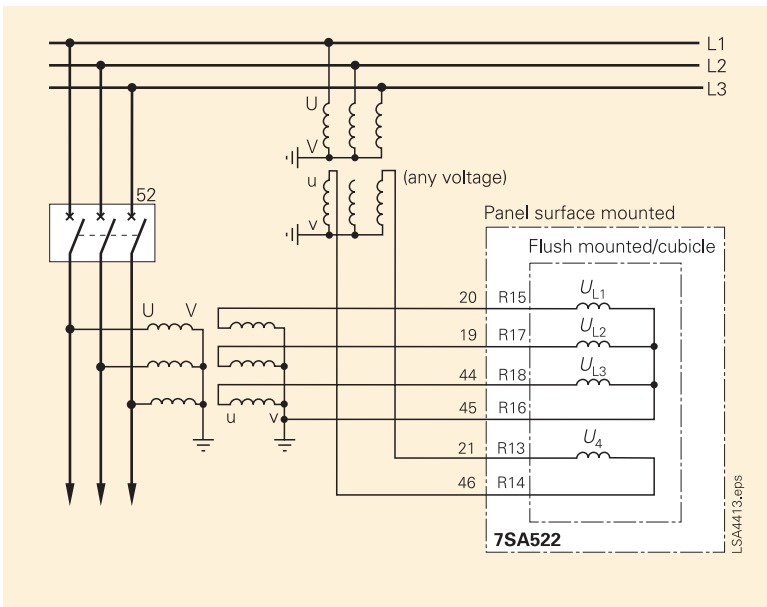

Fig. 6 VT connections

- 211 Matching ratio Phase-VT to Open-delta-VT:  
If in setting 210 the 4<sup>th</sup> voltage measuring input is selected to measure the open-delta voltage ( $3 U_0$ ) then this setting must be used to configure the transformation ratio difference between the phase VT and the open-delta VT. As sync. check is applied this setting has no relevance.
- 212 VT connection for sync. voltage:  
If the setting 210 for the 4<sup>th</sup> voltage measuring input is selected to measure the voltage for sync. check this setting must be applied to define which voltage is used for sync. check. In this example, the voltage connected to  $U_4$  is the phase-phase voltage L3-L1 as shown in Figure 6.

- 214A Angle adjustment  $U_{sync}-U_{line}$ :  
If there is a phase angle difference between the voltage  $U_{sync}$  and  $U_{line}$ , for example due to a power transformer with phase shifting vector group connected between the measuring points, then this phase shift must be set here. In this example the busbar is connected directly to the line so that there is  $0^\circ$  phase shift.
- 215 Matching ratio  $U_{line}-U_{sync}$ :  
If the transformation ratio of the VT for line voltage and sync. voltage measurement is not the same, then the difference must be set here. In this application:

$$\text{Ratio correction} = \frac{\frac{U_{\text{prim Line}}}{U_{\text{sec Line}}}}{\frac{U_{\text{prim BUS}}}{U_{\text{sec BUS}}}} = \frac{\frac{380}{0.1}}{\frac{400}{0.11}} = 1.05$$

The required setting is therefore 1.05.

- 220  $I_4$  current transformer is:  
The 4<sup>th</sup> current measurement may be used for a number of different functions. In this case it is used to measure the **Neutral Current (of the protected line)** by means of a Holmgreen connection. See Figure 5.
- 221 Matching ratio  $I_4/I_{ph}$  for CT's:  
If the CT connected to  $I_4$  has a different ratio, for example a core balance CT, to the ratio of the CT measuring the phase currents of the protected circuit, this difference must be set here. In this application the ratio is the same so the setting must be 1.00.

## 7.2 Power system data

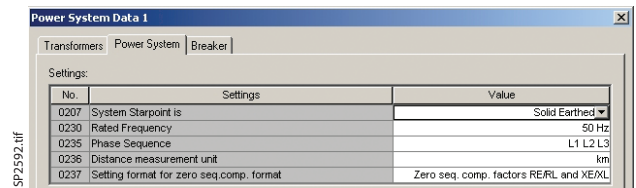
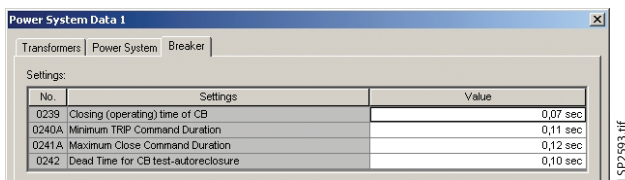

Fig. 7 Power system data

- 207 System Starpoint is:  
The condition of the system starpoint earthing must be set here. If the system starpoint is not effectively earthed, isolated or resonant earthed, then the distance protection response to simple earth faults will be stabilised to prevent operation on transient earth fault currents. In this example **Solid Earthed** applies.

- 230 **Rated Frequency:**  
Set the rated system frequency to **50 Hz or 60 Hz**.
- 235 **Phase Sequence:**  
The phase sequence of the system is usually positive, L1 L2 L3. If the system has negative phase sequence this can be set here. In this example the phase sequence is positive (L1 L2 L3).
- 236 **Distance measurement unit:**  
The distance measurement unit for the fault locator and certain line parameters can either be in km or in miles. In this example **km** is used.
- 237 **Setting format for zero seq. comp.:**  
The distance protection includes a zero sequence compensation so that the same reach settings apply to phase and earth faults. The zero sequence compensation can either be set as RE/RL and XE/XL parameters (standard format used by Siemens in the past) or as the complex ratio **KO** by means of a magnitude and angle setting. In this example the setting will be applied as **Zero seq. comp. factors RE/RL and XE/XL**.

### 7.3 Breaker



No.	Settings	Value
0239	Closing (operating) time of CB	0,07 sec
0240A	Minimum TRIP Command Duration	0,11 sec
0241A	Maximum Close Command Duration	0,12 sec
0242	Dead Time for CB test-autoreclosure	0,10 sec

Fig. 8 Breaker parameters

- 239 **Closing (operating) time of CB:**  
This setting is only relevant if synchro check with asynchronous switching is configured. Under asynchronous closing, the sync. check function will determine the instant for issuing the close command so that the primary CB contacts close when the switched voltages are in phase. For this purpose the time that expires after application of the close command to the close coil until the primary contacts of the CB make must be set here. From Table 2 the required setting is **0.07 s**.
- 240A **Minimum TRIP Command Duration:**  
The trip command to the circuit-breaker must have a minimum duration to ensure that the CB responds and to prevent premature interruption of the current in the trip coil which may cause damage to the trip contact which is not rated to interrupt such a large inductive current.
- 241A **Maximum Close Command Duration:**  
The close command must also have a minimum duration to ensure that the circuit-breaker can respond and that the auxiliary contacts can interrupt the current flow through the close coil. If, following a close command, a trip is issued due to switch on to fault, the close command is reset immediately by the new trip command. The close command maximum duration should be set at least as long as the maximum time required by the CB auxiliary contact to interrupt the close coil current after start of the close command. From Table 2 the given circuit-breaker operating time is seen to be 70 ms. A safety margin of 50 ms is sensible so that a setting of **0.12 s** is applied.
- 242 **Dead Time for CB test-autoreclosure:**  
One of the test features in DIGSI is the CB test-autoreclosure. For this test the circuit-breaker is tripped and reclosed under normal load conditions. A successful test proves that the trip and close circuits and the CB are in a fully functional state. As the test causes a disruption to the power flow (either single phase or three phase), the dead time should be as short as possible. While a normal dead time must allow for the time required by the fault arc to dissipate (typically 0.5 s for three-pole trip and 1s for single-pole trip), the test cycle must only allow for the circuit-breaker mechanism to open and close. Here a dead time of **0.10 s** is usually sufficient.
- When primary current flow is detected (measured current > pole open current: Parameter 1130) then the trip command is sealed in by the current flow and will only reset once the current flow is interrupted (refer to Figure 9). When the trip command is issued and no current flow is detected, the minimum trip command duration set here will apply. It must be set longer than the maximum time taken for the CB auxiliary contacts to open and interrupt the current in the trip coil following the start of the trip command. The reset conditions for the trip command can be set with parameter “1135 RESET of Trip Command”. From Table 2 the given circuit-breaker operating time is seen to be 60 ms. A safety margin of 50 ms is sensible so that a setting of **0.11 s** is applied.

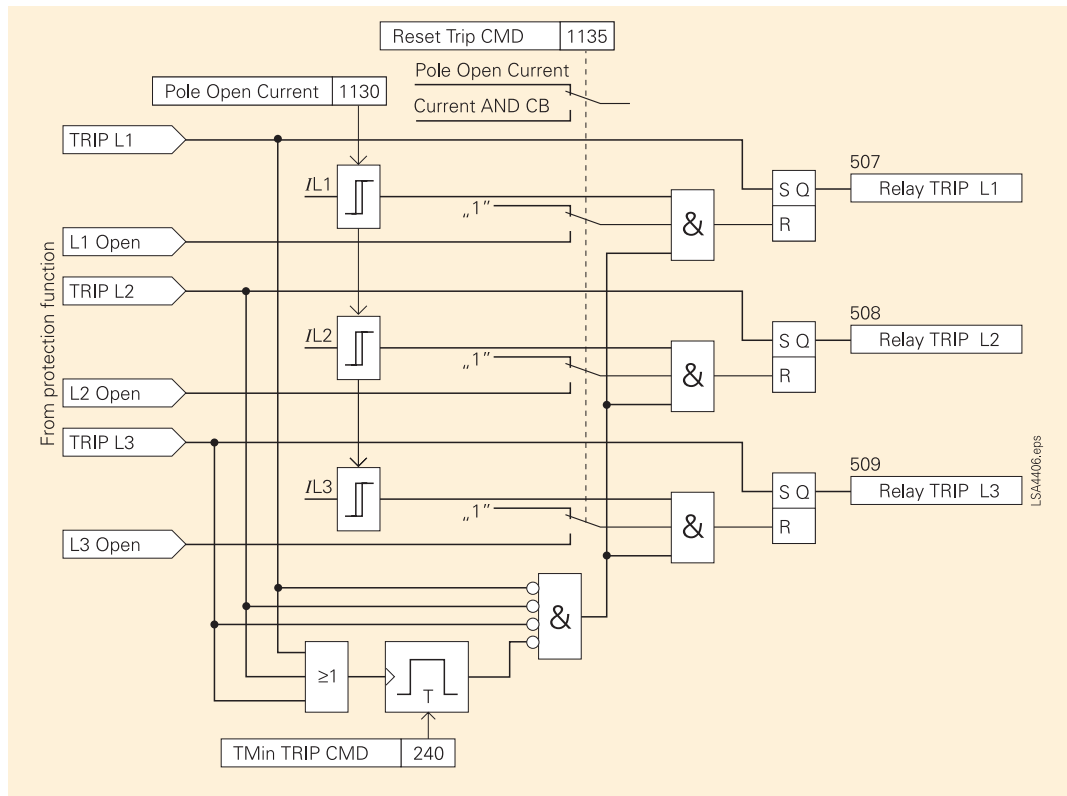

Fig. 9 Trip command seal in

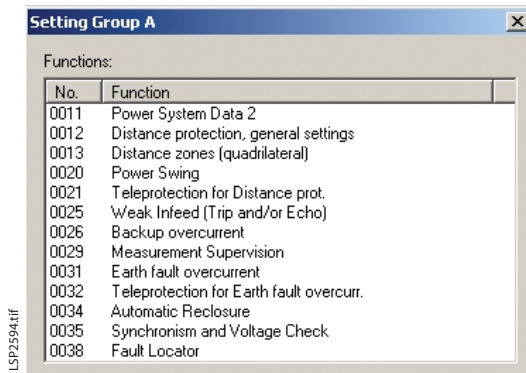

Fig. 10 Setting blocks available in Setting Group A for this application

8. Settings for Setting Group A

The setting blocks that are available in Setting Group A depend on the selections made during the selection of the device configuration (Heading 4). If the setting group changeover had been activated, a total of 4 setting groups would have been available.

9. Settings for Power System Data 2

Further power system data, in addition to Power System Data 1, is set here. As these parameters are inside Setting Group A, they can be modified between the setting groups if setting group changeover is activated.

No.	Settings	Value
1103	Measurement: Full Scale Voltage (100%)	400,0 kV
1104	Measurement: Full Scale Current (100%)	866 A
1105	Line Angle	83 °
1211	Angle of inclination, distance charact.	83 °
1107	P,Q operational measured values sign	reversed
1110	x' - Line Reactance per length unit	0,0553 Ohm / km
1111	Line Length	80,0 km
1116	Zero seq. comp. factor RE/RL for Z1	1,40
1117	Zero seq. comp. factor XE/XL for Z1	0,95
1118	Zero seq. comp. factor RE/RL for Z1B...Z5	1,38
1119	Zero seq. comp. factor XE/XL for Z1B...Z5	1,07

Fig. 11 Power system settings in Power System Data 2

9.1 Power system

1103 Measurement: Full Scale Voltage (100 %): For the indication and processing of measured values it is important to set the full scale value on the primary side. This does not have to correspond to the VT rated primary voltage. When the primary value corresponds to this setting the percentage measured value will be 100 %. Other percentage measured values that also depend on voltage, such as for example power (P) will also have the full scale indication dependant on this setting. In Table 2 the system rated voltage is given and therefore set at 400 kV.



- 1104 Measurement: Full Scale Current (100%): For the indication and processing of measured values it is important to set the full scale value on the primary side. This does not have to correspond to the CT rated primary current. When the primary value corresponds to this setting the percentage measured value will be 100 %. Other percentage measured values that also depend on current, such as for example power ( $P$ ) will also have the full scale indication dependant on this setting. In Table 2 the rated apparent power of the line is stated at 600 MVA:

$$\text{Full scale current} = \frac{\text{Rated MVA}}{\sqrt{3} \cdot \text{Full scale voltage}}$$

$$\text{Full scale current} = \frac{600}{\sqrt{3} \cdot 400} = 866 \text{ A}$$

The measurement: Full scale current (100 %) is therefore set to 866 A.

- 1105 Line Angle: The line angle setting is calculated from the positive sequence line impedance data. In this example:

$$Z_1 = 0.025 + j0.21$$

$$\text{Line angle} = \arctan\left(\frac{X_L}{R_L}\right)$$

$$\text{Line angle} = 83^\circ$$

- 1211 Angle of inclination, distance charact.: This is usually set the same as the line angle. In this manner the resistance coverage for all faults along the line is the same (Fig. 12). Therefore set for this application the angle of inclination of the distance characteristic equal to the line angle which is 83°.
- 1107  $P, Q$  operational measured values sign: The measured values  $P$  and  $Q$  are designated as positive when the power flow is into the protected object. If the opposite sign is required, this setting must be changed so that the sign of  $P$  and  $Q$  will be reversed. In Table 2 the sign convention for power flow states that exported power (flowing into the line) is designated as negative. The setting here must therefore be reversed.

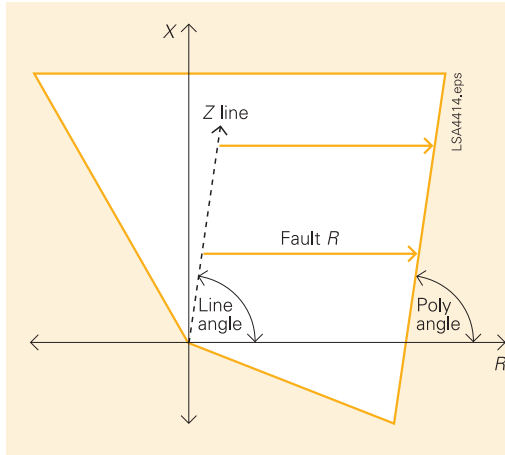

Fig. 12 Polygon and line angle

- 1110  $x'$ -Line Reactance per length unit: The line reactance per length unit (in this example per km) is required for the fault locator output in km (miles) and percent. In Table 2 this is given as 0.21  $\Omega/\text{km}$  primary. The setting can therefore be applied as primary value 0.2100  $\Omega/\text{km}$ , or it can be converted to a secondary value:

$$x'_{\text{secondary}} = \frac{\text{CT ratio}}{\text{VT ratio}} \cdot x'_{\text{primary}} = \frac{1000}{380} \cdot 0.21$$

$$x'_{\text{secondary}} = 0.0553$$

The setting in secondary impedance is 0.0553  $\Omega/\text{km}$ .

- 1111 Line Length: The line length setting in km (miles) is required for the fault locator output. From Table 2 set 80.0 km.
- 1116 Zero seq. comp. factor  $R_E/R_L$  for  $Z_1$ : The zero sequence compensation setting is applied so that the distance protection measures the distance to fault of all fault types based on the set positive sequence reach. The setting is applied as  $R_E/R_L$  and  $X_E/X_L$  setting; here  $R_E/R_L$  for Zone 1 with the data for Line 1 from Table 2.
- $$\frac{R_E}{R_L} = \frac{1}{3} \cdot \left( \frac{R_0}{R_1} - 1 \right) = \frac{1}{3} \cdot \left( \frac{0.13}{0.025} - 1 \right) = 1.4$$
- Apply setting  $R_E/R_L$  for  $Z_1$  equal to 1.40.

- 1117 Zero seq. comp. factor  $X_E/X_L$  for Z1:  
The same consideration as for parameter 1116 above applies:

$$\frac{X_E}{X_L} = \frac{1}{3} \cdot \left( \frac{X_0}{X_1} - 1 \right) = \frac{1}{3} \cdot \left( \frac{0.81}{0.21} - 1 \right) = 0.95$$

Apply setting  $X_E/X_L$  for Z1 equal to **0.95**.

- 1118 Zero seq. comp. factor  $R_E/R_L$  for Z1B...Z5:  
As the overreaching zones cover the protected line as well as adjacent circuits, the zero sequence compensating factor must take the impedance parameters of the protected line as well as the adjacent lines into account. The Zone 2 reach has to be co-ordinated with the protection on the shortest adjacent feeder (Line 3) so that the Zone 2 reach will be used to determine this setting. The other zone reaches are largely influenced by other system conditions such as parallel and intermediate infeeds:

If the Zone 2 reach is set to 80 % of the total impedance up to the Zone 1 reach on Line 3 (shortest adjacent line) then the total positive sequence impedance at the Zone 2 reach limit is:

$$X_{2_1} = 0.8 \cdot (X_{Line1} + 0.8 \cdot X_{Line3})$$

$$X_{2_1} = 0.8 \cdot (80 \cdot 0.21 + 0.8 \cdot 17.5) = \underline{\underline{24.64}}$$

$$R_{2_1} = R_{Line1} + \frac{(X_{2_1} - X_{Line1})}{X_{Line3}} \cdot R_{Line3}$$

$$R_{2_1} = 80 \cdot 0.025 + \frac{24.64 - 80 \cdot 0.21}{17.5} \cdot 1.5 = 2.672$$

The corresponding zero sequence impedance is calculated as follows:

$$X_{2_0} = X_{0_{Line1}} + \frac{(X_{2_1} - X_{Line1})}{X_{Line3}} \cdot X_{0_{Line3}}$$

$$X_{2_0} = 80 \cdot 0.81 + \frac{24.64 - 80 \cdot 0.21}{17.5} \cdot 86.5$$

$$X_{2_0} = 1034$$

$$R_{2_0} = R_{0_{Line1}} + \frac{(X_{2_1} - X_{Line1})}{X_{Line3}} \cdot R_{0_{Line3}}$$

$$R_{2_0} = 80 \cdot 0.13 + \frac{24.64 - 80 \cdot 0.21}{17.5} \cdot 7.5$$

$$R_{2_0} = 13.76$$

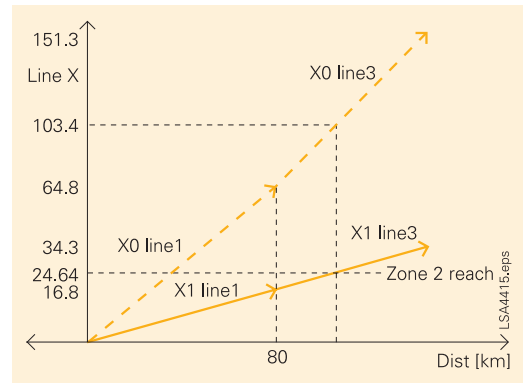

Fig. 13 Positive and zero sequence line impedance profile

This is graphically shown for the X values in Figure 13. A similar drawing can also be made for the R values. Always use the Zone 2 setting in the X direction as a reference. Now apply the derived values,  $X_{2_1}$ ,  $R_{2_1}$ ,  $X_{2_0}$  and  $R_{2_0}$  to the following equation:

$$\frac{R_E}{R_L} = \frac{1}{3} \cdot \left( \frac{R_0}{R_1} - 1 \right) = \frac{1}{3} \cdot \left( \frac{13.76}{2.672} - 1 \right) = 1.38$$

Apply setting  $R_E/R_L$  for Z1B...Z5 equal to **1.38**.

- 1119 Zero seq. comp. factor  $X_E/X_L$  for Z1B...Z5:  
This is the  $X_E/X_L$  setting corresponding to the  $R_E/R_L$  setting 1118 above. Therefore apply the derived values,  $X_{2_1}$ ,  $R_{2_1}$ ,  $X_{2_0}$  and  $R_{2_0}$  to the following equation:

$$\frac{X_E}{X_L} = \frac{1}{3} \cdot \left( \frac{X_0}{X_1} - 1 \right) = \frac{1}{3} \cdot \left( \frac{1034}{24.64} - 1 \right) = 1.07$$

Apply setting  $X_E/X_L$  for Z1B...Z5 equal to **1.07**.

## 9.2 Line status

### 1130A Pole Open Current Threshold:

For a number of functions in the relay the switching state of the circuit-breaker is an important logical information input. This can be derived via auxiliary contacts or by measuring the current flow in the circuit. With this parameter the current threshold is set to determine the pole open condition of the circuit-breaker. If the phase current measured by the relay is below this threshold this condition for pole open detection is true.

This setting should be as sensitive as possible (setting equal to or lower than the smallest current pick-up threshold of a protection function). Stray induced currents during a true open pole condition may however not cause incorrect pick-up.

In this example no special conditions have to be considered, so the default setting of 0.10 A is maintained.

### 1131A Pole Open Voltage Threshold:

As was described for the pole open current above (1130A), the pole open voltage setting determines the threshold below which the voltage condition for pole open is true.

As single-pole tripping will be applied here and the voltage transformers are located on the line side of the circuit-breaker, the setting should be large enough to ensure that the voltage induced on the open phase is below this setting. Apply a setting that is at least 20 % below the minimum operating phase to earth voltage.

In this example the minimum operating voltage is 85 % of nominal voltage:

$$\text{Setting} < 0.8 \cdot 0.85 \cdot 400 \text{ kV} / 380 \text{ kV} \cdot 100 / \sqrt{3} < 41$$

Therefore apply a setting of 40 V.

### 1132A Seal-in Time after ALL closures:

When the feeder is energised the switch on to fault (SOTF) protection functions are activated. The line closure detection conditions are set with parameter 1135 below. This seal-in time setting applies to all line closure detections other than the manual close binary input condition. This direct detection of circuit-breaker closing responds almost at the same instant as the primary circuit-breaker contact closing. A fairly short seal in time can therefore be set here to allow for pick-up of the desired protection functions.

No.	Settings	Value
1130A	Pole Open Current Threshold	0,10 A
1131A	Pole Open Voltage Threshold	40 V
1132A	Seal-in Time after ALL closures	0,05 sec
1134	Recognition of Line Closures with	Current OR Voltage or Manual close BI
1135	RESET of Trip Command	with Pole Open Current Threshold only
1140A	CT Saturation Threshold	24,0 A
1150A	Seal-in Time after MANUAL closures	0,30 sec
1151	Manual CLOSE COMMAND generation	NO
1152	MANUAL Closure impulse after CONTROL	<none>

Fig. 14 Line status settings in Power System Data 2

In this application only the distance protection will be used for switch on to fault so that a setting of 0.05 s is sufficient.

### 1134 Recognition of Line Closure with:

As stated above (1132A) the recognition of line closure is important for the switch on to fault protection functions. If the manual close binary input is assigned in the matrix, it will be one of the line closure detection criteria. If other circuit-breaker closing conditions such as auto-reclose or remote closing are applied then it is advisable to apply additional criteria for line closure detection. In the table below the prerequisites for application of the individual conditions are marked with X.

1134 Recognition of Line Closure with:	Manual Close BI allocated in Matrix	CB aux allocated in Matrix	VT on line side of CB
Manual Close BI	X		
Voltage			X
Current flow	Always valid	Always valid	Always valid
CB aux		X	

Table 4 Prerequisites for application of individual conditions in Parameter 1134

In this example, the manual close binary input and CB aux contacts are not allocated in the Matrix, so the conditions Voltage and Current flow must be used for line closure detection. As the voltage transformers are on the line side, the setting **Current or Voltage or Manual Close BI** is applied. Note that the inclusion of Manual Close is of no consequence because the binary input is not allocated in the Matrix.

1135 RESET of Trip Command:  
The trip command duration must always be long enough to allow the circuit-breaker auxiliary contacts to interrupt the current flowing through the trip coil. The most reliable method for sealing in the trip command is the detection of current flow in the primary circuit through the CB. The auxiliary contact status may be used as an additional condition. This is helpful when trip commands are issued in the absence of primary current flow, e.g. during testing or by protection functions that do not respond to current flow such as voltage or frequency protection. In this example, the auxiliary contacts are not allocated in the Matrix so that the trip command is reset with Pole Open Current Threshold only.

1140A CT Saturation Threshold:  
CT saturation is normally detected by monitoring of harmonic content in the measured current. This is not possible for protection response below 1 cycle as at least one cycle of recorded fault current is required to determine the harmonic content. Below one cycle the CT saturation condition is therefore set when the current exceeds this threshold. The following calculation gives an approximation of this current threshold:

$$\text{CT Saturation Threshold} = \frac{n'}{5} \cdot I_N$$

with

$$n' = n \cdot \frac{P_N + P_i}{P' + P_i} = \text{actual overcurrent factor}$$

$P'$  = the actual burden connected to the secondary CT relay burden + CT secondary connection cable burden

In this example only the 7SA relay is connected to the CT, so that the relay burden is 0.05 VA per phase. Due to the Holmgreen connection, the maximum burden for earth currents is therefore twice 0.05 VA = 0.1 VA.

The CT secondary cable connection burden is calculated as follows:

$$R_{\text{cable}} = \frac{2 \cdot l_{\text{cable}} \cdot \rho_{\text{CU}}}{a_{\text{cable}}}$$

$$\begin{aligned} l_{\text{cable}} &= 50 \text{ m} \\ \rho_{\text{CU}} &= 0.0179 \text{ } \Omega\text{mm}^2/\text{m} \\ a_{\text{cable}} &= 2.5 \text{ mm}^2 \end{aligned}$$

therefore:

$$R_{\text{cable}} = \frac{2 \cdot 50 \cdot 0.0179}{2.5}$$

$$R_{\text{cable}} = 0.72 \text{ } \Omega$$

at 1 A nominal secondary current, this relates to:

$$P' = R_{\text{cable}} \cdot I_{\text{N CT}}^2 + P_{\text{relay}}$$

$$P' = 0.72 \cdot 1^2 + 0.1$$

$$P' = 0.82 \text{ VA}$$

From Table 2, the CT data is 5P20 20 VA, therefore:

$$n' = 20 \cdot \frac{20 + 3}{0.82 + 3} = 120$$

with this value, the setting can then be calculated:

$$\text{CT Saturation Threshold} = \frac{120}{5} \cdot 1 \text{ A} = 24 \text{ A}$$

The applied setting in this case is therefore 24.0 A.

- 1150A Seal-in Time after MANUAL closures:  
This setting is only applicable when the manual close binary input is allocated in the Matrix (refer to setting 1134 above). The time applied here should allow for the circuit-breaker response and any additional delays such as sync. check release which can occur between the initiation of the binary input and closure of the CB primary contacts. In this example, the manual close binary input is not allocated so this setting is of no consequence and therefore left on the default value of 0.30 s.
- 1151 Manual CLOSE COMMAND generation:  
If the manual close binary input is allocated, it may be used to generate a close command to the circuit-breaker in the relay. Alternatively the input may be used only to inform the relay that a manual close has been issued externally to the circuit-breaker. If the relay has to generate a close command following the initiation, this can be done with or without sync. check if the internal sync. check function is available. In this example the manual close binary input is not allocated so this setting should be set to NO.

### 1152 MANUAL Closure Impulse after CONTROL:

If the internal control functions are used, either via front keypad or system interface, the issued control-CLOSE command to the circuit-breaker can be used to activate the protection functions in the same manner as the manual-close binary input would. The setting options provided consist of all the configured controls in the device. In this example, the internal control functions are not used, so this setting is left on the default value: <none>

### 9.3 Trip 1/3-pole

As 1 and 3-pole tripping is applied in this example, the following settings must be applied:

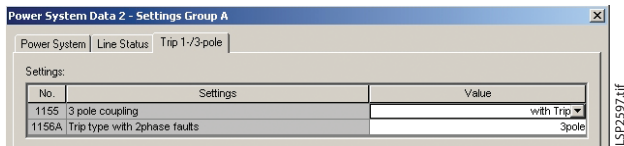

Fig. 15 Trip 1/3-pole settings in Power System Data 2

### 1155 3 pole coupling:

When single-pole tripping is applied the relay must select the faulted phase and trip single pole selectively. In the event of 2 simultaneous faults, e.g. inter-circuit fault on double circuit line, the relay detects two faulted phases, but only one of the two is inside a tripping zone. To ensure single-pole tripping under these conditions, set 3-pole coupling to **with Trip**.

### 1156A Trip type with 2phase faults:

Phase to phase faults without ground, can be cleared by single-pole tripping. On circuits where such faults occur frequently, e.g. conductor clashing due to conductor galloping with ice and wind conditions, single-pole tripping for 2-phase faults can improve availability of the circuit. The setting at both line ends must be the same. If single-pole tripping is selected, either the leading or lagging phase will then be tripped at both line ends. In this example 2-phase faults will be tripped **3-pole**.

## 10. Distance protection, general settings – Setting Group A

### 10.1 General

No.	Settings	Value
1201	Distance protection is	ON
1202	Phase Current threshold for dist. meas.	0,10 A
1211	Angle of inclination, distance charact.	83°
1208	Series compensated line	NO
1232	Instantaneous trip after SwitchOnToFault	with Zone Z1B
1241	R load, minimum Load Impedance (ph-e)	23,800 Ohm
1242	PHI load, maximum Load Angle (ph-e)	26°
1243	R load, minimum Load Impedance (ph-ph)	23,800 Ohm
1244	PHI load, maximum Load Angle (ph-ph)	26°
1317A	Single pole trip for faults in Z2	NO
1357	Z1B enabled before 1st AR (int. or ext.)	NO

Fig. 16 General settings for distance protection

### 1201 Distance protection is:

If the distance protection must be switched off in this setting group, it can be done so with this setting.

In this example, only one setting group is used and the distance protection function is required so this setting is left on the default value which is **ON**.

### 1202 Phase Current threshold for dist. meas.:

Although the distance protection responds to the impedance of the faulted loop, a lower limit must apply for the current flow before the distance protection responds. If the system conditions can not ensure that this minimum current flows during all internal short-circuit faults, special weak infeed measures may be required (see chapter 14). It is common practice to apply a very sensitive setting here so that the back-up functionality of the distance protection for remote faults on other circuits is effective. The default setting of 10 % is therefore commonly applied. In this application, no special conditions exist, so the default setting of **0.10 A** is applied.

### 1211 Angle of inclination, distance charact.:

This setting was already discussed and applied in chapter 9.1 “Power system”, where its association with the line angle was described. It is set to **83°**.

### 1208 Series compensated line:

On feeders in the vicinity of series capacitors, special measures are required for direction measurement. This application is without series capacitors on the protected or adjacent feeders, so the setting applied is **NO**.



- 1232 Instantaneous trip after SwitchOnToFault: When the protected circuit is switched off, a permanent fault (e.g. working earth or broken conductor on ground) may be present. After switching on the circuit, such faults must be cleared as fast as possible. It is common practice to activate non-selective stages with fast tripping for switch on to fault conditions. In the distance protection a number of alternatives exists:

Setting	Distance protection during SOTF
Inactive	No special measures
With pickup (non-directional)	All distance zones are released for instantaneous tripping
With Zone Z1B	The Zone Z1B is released for instantaneous tripping and will operate with its set direction if a polarising voltage is available
Zone Z1B undirectional	The Zone Z1B is released for instantaneous tripping and will operate as a non-directional zone. (MHO characteristic as forward and reverse zone)

**Table 5** Setting alternatives for SOTF with distance protection

It is recommended to use the distance protection for SOTF conditions. In many cases the setting “with pickup (non-directional)” would result in a reach that operates due to heavy load inrush, e.g. when large machines and transformers are connected to the feeder so that the energising current is more than twice the full load current. In these cases the Zone Z1B can be applied as its reach is typically only between approx. 120 % and 200 % of the protected feeder. Of special interest is the application of Zone Z1B undirectional. If the local busbar can be energised from the remote end via the protected feeder, then SOTF conditions for busbar faults can be provided by application of this setting. Note that the line closure detection should not be with the voltage condition in this case, as the live line voltage prior to energising the busbar would prevent the SOTF release. In this example, the local bus will not be energised via the feeder so the setting with Zone Z1B is applied.

- 1241 R load, minimum Load Impedance (ph-e): The settings 1241 to 1244 determine the “load encroachment area” for the distance relay setting characteristic. The distance zone settings must exclude the load area in the impedance plane so that operation is only possible under fault conditions. For

this purpose, the smallest load impedance and the largest load impedance angle must be determined (refer to Fig. 17).

The load encroachment area is set for phase to earth loops (parameter 1241 and 1242) and for phase to phase loops (parameter 1243 and 1244) separately. Normally load conditions will not cause earth fault detection as no zero sequence current is present in the load. In the event of single-pole tripping of adjacent circuits, an earth-fault detection and increased load current flow may be present at the same time. For such contingencies, the load encroachment must also be set for earth-fault characteristics.

$$R_{\text{load min}} = \frac{U_{\text{operation min}}}{\sqrt{3} \cdot I_{\text{load max}}}$$

From Table 1, the minimum operating voltage is 85 % of nominal system voltage, and the maximum load current is 250 % of the full load apparent power.

$$U_{\text{operation min}} = 0.85 \cdot 400 \text{ kV} = 340 \text{ kV}$$

$$I_{\text{load max}} = 2.5 \cdot \frac{600 \text{ MVA}}{\sqrt{3} \cdot 400 \text{ kV}} = 2170 \text{ A}$$

By substituting these values in the above equation:

$$R_{\text{load min}} = \frac{340 \text{ kV}}{\sqrt{3} \cdot 2170} = 90.5 \ \Omega$$

To convert this to a secondary value, multiply it with the factor 0.2632 (Table 2) to obtain the setting **23.8 Ω**. As worst case conditions are assumed, a safety factor is not required. If the parameters for calculation are less conservative, a safety factor, e.g. 10 to 20 % may be included in the calculation.

- 1242 PHI load, maximum Load Angle (ph-e): To determine the largest angle that the load impedance may assume, the largest angle between operating voltage and load current must be determined. As load current ideally is in phase with the voltage, the difference is indicated with the power factor  $\cos \varphi$ . The largest angle of the load impedance is therefore given by the worst, smallest power factor. From Table 2 the worst power factor under full load conditions is 0.9:

$$\varphi_{\text{load-max}} = \arccos(\text{power factor}_{\text{min}})$$

$$\varphi_{\text{load-max}} = \arccos(0.9) = 26^\circ$$

The power factor under full load conditions should be used for this calculation, as under lightly loaded conditions the VAR flow may dominate, but under these conditions the load impedance is not close to the set impedance reach. In this case the setting for PHI load, maximum Load Angle (ph-e) is  $26^\circ$ .

- 1243 R load, minimum Load Impedance (ph-ph):  
No distinction is made in this example between the maximum load during phase to earth pickup (adjacent circuit single-pole open) and phase to phase pickup, e.g. when parallel circuit is three-pole tripped. Therefore the same setting as for 1241 is applied here, being  $23.8 \Omega$ .
- 1244 PHI load, maximum Load Angle (ph-ph):  
Again the same setting as for the phase to earth loop is applied here, being  $26^\circ$ .

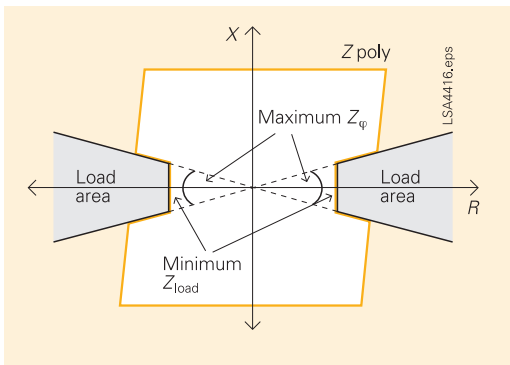

Fig. 17 Load encroachment characteristic

- 1317A Single pole trip for faults in Z2:  
For special applications, single-pole tripping by Zone 2 can be applied. However, time delayed protection stages are usually applied with 3-pole tripping. In this example, 3-pole tripping in Zone 2 is desired so the default setting of NO is left unchanged.
- 1357 Z1B enabled before 1st AR (int. or ext.):  
In this example a teleprotection scheme (POTT) is applied. The controlled Zone Z1B operation is therefore subject to the signals from the teleprotection scheme. In an application where no teleprotection scheme is applied or in the case of a reception failure of the teleprotection scheme, the Zone Z1B can also be controlled by the auto-reclose function.

This achieves fast tripping for all faults on the feeder although some non-selective trips can also occur. This is tolerated in such a scheme because following all fast trips there is an automatic reclosure. In this example, the Z1B will only be controlled by the teleprotection, the setting NO is therefore applied.

## 10.2 Earth faults

No.	Settings	Value
1203	$3I_0$ threshold for neutral current pickup	0,10 A
1204	$3U_0$ threshold zero seq. voltage pickup	5 V
1207A	$3I_0$ -pickup-stabilisation ( $3I_0 > I_{phmax}$ )	0,10
1209A	criterion of earth fault recognition	$3I_0 > \text{OR } 3U_0 >$
1221A	Loop selection with 2Ph-E faults	block leading ph-e loop

Fig. 18 Earth-fault settings for distance protection

- 1203  $3I_0$  threshold for neutral current pickup:  
The distance protection must identify the faulted loop to ensure correct response. If an earth-fault is present, this is detected by the earth-fault detection. Only in this case will the three earth loop measurements be released subject to further phase selection criteria. The earth current pickup is the most important parameter for the earth-fault detection. Its threshold must be set below the smallest earth current expected for faults on the protected feeder. As the distance protection is also set to operate as backup protection for remote external faults, this setting is set far more sensitive than required for internal faults. In chapter 3 the minimum single-phase fault current for internal faults neglecting fault resistance was calculated to be 1380 A. To allow for fault resistance and reach into adjacent feeders for back-up, the setting applied here should be substantially lower than this calculated value. In this example, the default value of 0.10 A secondary (100 A primary) is maintained.

1204  $3U_0$  threshold zero seq. voltage pickup:  
 A further criteria for earth-fault detection is the zero sequence voltage. In an earthed system, zero sequence voltage is always present during earth faults and it decreases as the distance between the measuring point and the fault location increases. This threshold setting is therefore also used for earth-fault detection as shown in the logic diagram, Fig. 19. When the zero sequence source impedance is large, the zero sequence current component in the fault current may become small. In such an event, the zero sequence voltage will however be relatively large due to the small zero sequence current flowing through the large zero sequence source impedance. For secure earth-fault detection the default setting of 5 V is maintained. If system unbalance during unfaulted conditions causes larger zero sequence voltages then this setting should be increased to avoid earth-fault detection under these circumstances.

1209A Criterion for earth fault recognition:  
 For the settings 1203 and 1204 above, and in Fig. 19, the method and logic of the earth-fault detection were explained. With this setting the user has the means to influence the earth-fault detection logic. In earthed systems it is recommended to use the very reliable OR combination of zero sequence current and voltage for the earth-fault detection. As mentioned before, these two criteria supplement each other so that small zero sequence current is often associated with large zero sequence voltage at weak infeeds and the other way around at strong infeeds. The AND setting is only for exceptional conditions when, for example, the zero sequence voltage or current on their own are not a reliable indicator for earth faults. In this example, the default setting OR is maintained for the reasons stated above.

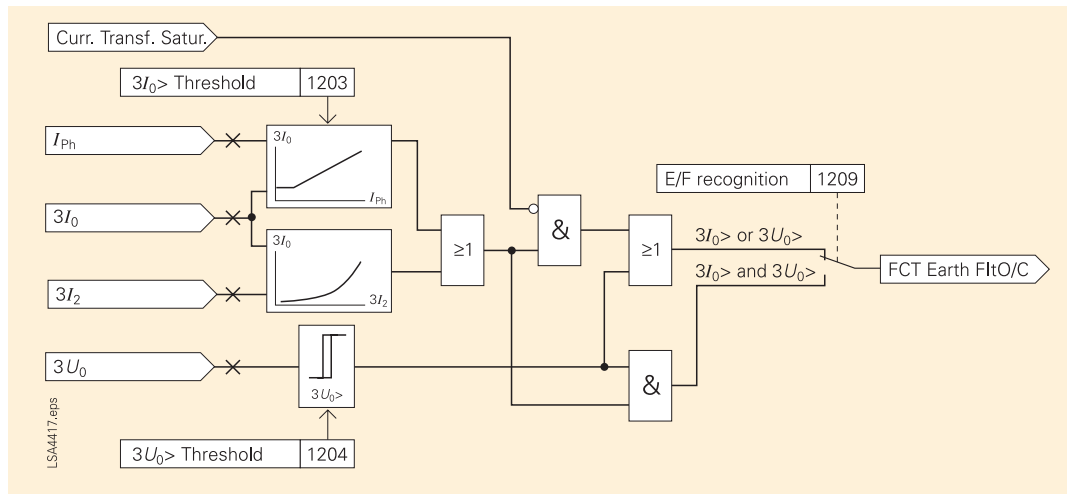

Fig. 19 Earth-fault detection logic

1207A  $3I_0 >$  pickup stabilisation ( $3I_0 > / I_{ph \max}$ ):  
 In the event of large phase currents, the system unbalance (e.g. non-transposed lines) and CT errors (e.g. saturation) can cause zero sequence current to flow via the measuring circuit of the relay although no earth fault is present. To avoid earth-fault detection under these conditions, the zero sequence current pickup is stabilised by this set factor. Unless extreme system unbalance or exceptionally large CT errors are expected, the default setting of 10 % i.e. 0.10 can be maintained, as is done for this example.

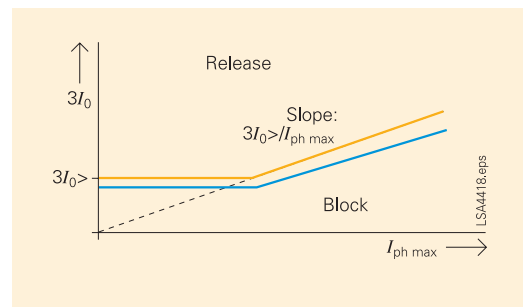

Fig. 20 Stabilised zero sequence pickup threshold

1221A Loop selection with 2Ph-E faults:

If some fault resistance (arc voltage) is present, then the measured fault loop impedances are affected by this additional voltage drop in the short-circuit loop. In the case of 2Ph-E faults this is most severe as the current in the fault resistance stems from 3 different short-circuit loops. Theoretical analysis and simulations show the following distribution of the measured loop impedances for a 2Ph-E fault:

The influence of load (remote infeed and load angle) can increase or decrease the rotation of the measured fault resistances. The leading phase to earth loop will however always tend to produce an overreach. For this reason, the default setting of **block leading Ph-E loop** will be used in this example. If the application is on a double circuit line where simultaneous earth faults on both lines can occur, the setting only phase-earth loops or all loops should be used to avoid blocking of the internal fault loop by this setting. Of course additional grading margin must be applied for Zone 1 in this case to avoid an overreach during an external 2Ph-E fault.

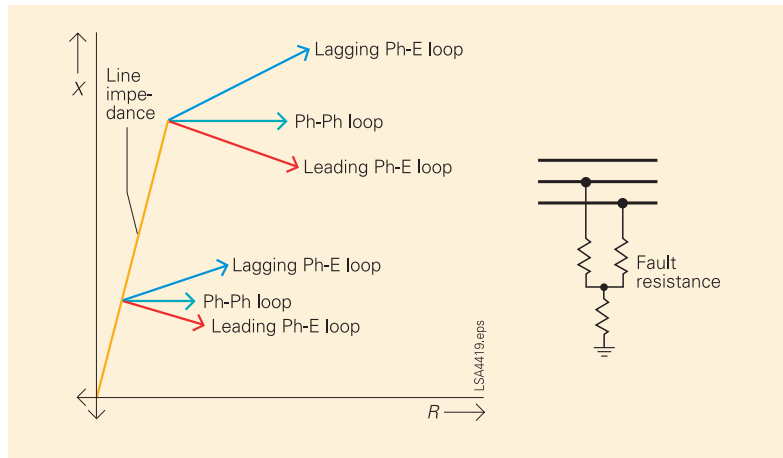

Fig. 21 Impedance distribution for 2ph-E fault with fault resistance

10.3 Time delays

1210 Condition for zone timer start:

During internal faults, all time delayed zones pickup unless there is substantial fault resistance and very strong remote infeed.

Although the fault in Fig. 23 is an internal fault it is measured only by Zone Z4 due to the fault resistance and strong remote infeed. If all zone timers are started by the distance pickup, the fault will be cleared by the relay with the set Zone 2 time after fault inception because the measured impedance moves into Zone 2 as soon as the remote, strong infeed trips the breaker on the right hand side.

From the timing diagram in Fig. 24 the influence of this setting can be seen. If the zone timers are started with distance pickup, the trip signal is issued with Zone 2 time delay (250 ms) after fault inception (distance pickup) although the Zone 2 only picks up some time later when the remote end has opened the circuit-breaker on the right hand side. The timing of the trip signals is therefore as if the fault had been inside the Zone 2 all along. For external fault back-up tripping similar operation by higher zones is achieved. This mode of operation will be applied in this example, so the setting with **distance pickup** is applied.

Distance protection, general settings - Settings Group A

General | Earth faults | Time Delays

Settings:

No.	Settings	Value
1210	Condition for zone timer start	with distance pickup
1305	T1-1 phase, delay for single phase faults	0,00 sec
1306	T1 multi-ph, delay for multi phase faults	0,00 sec
1315	T2-1 phase, delay for single phase faults	0,25 sec
1316	T2 multi-ph, delay for multi phase faults	0,25 sec
1325	T3 delay	0,50 sec
1335	T4 delay	∞ sec
1345	T5 delay	0,75 sec
1355	T1B-1 phase, delay for single ph. faults	0,00 sec
1356	T1B-multi-ph, delay for multi ph. faults	0,00 sec

Fig. 22 Time delay setting for the distance zones

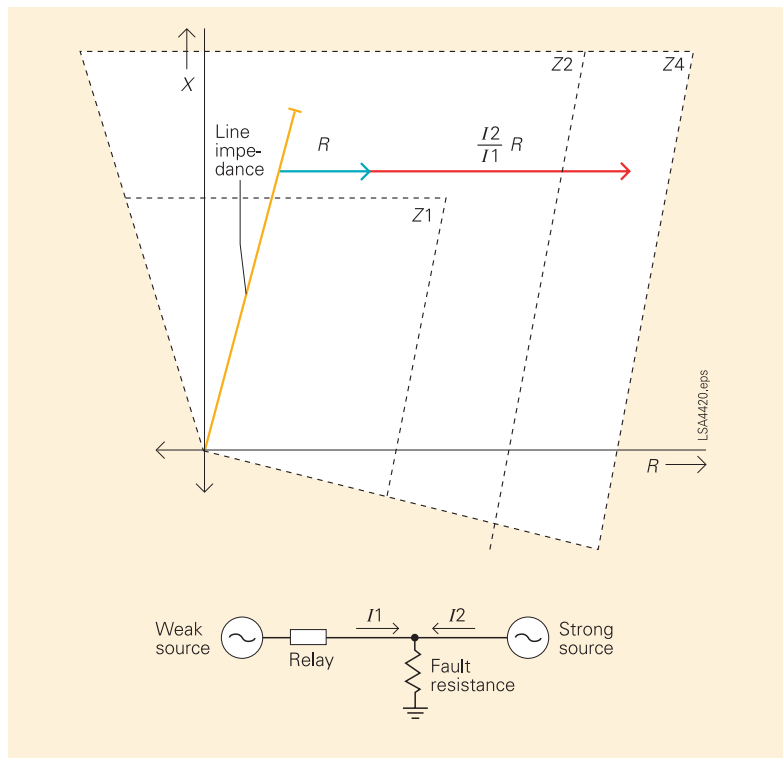

Fig. 23 Influence of fault resistance and remote infeed on measured impedance

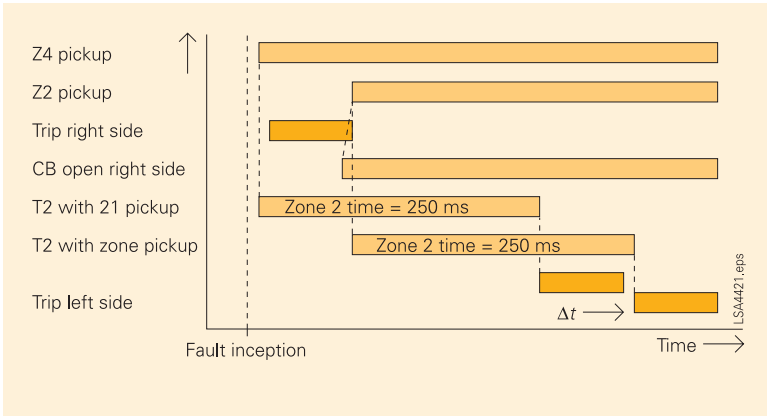

Fig. 24 Timing diagram for fault in Fig. 23

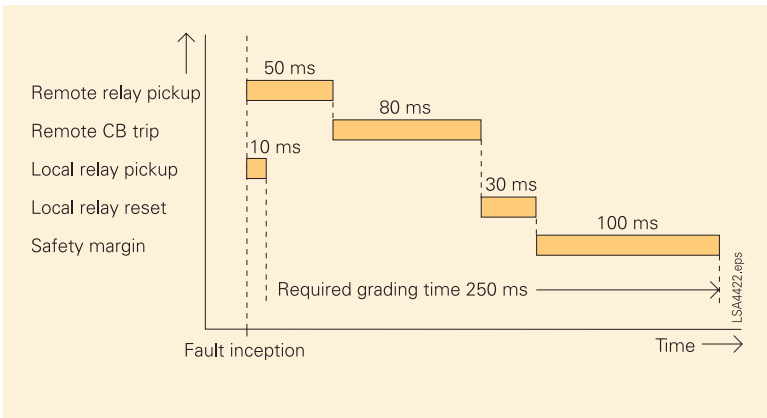

Fig. 25 Time chart to determine time step for graded protection

If co-ordination with other distance or overcurrent protection is required, the setting “with zone pickup” can be applied. For the scenario described in Fig. 23 and 24 this will however result in additional time delay ( $\Delta t$  in Fig. 24). During external faults with backup protection operation this time delay may become very long, often a full time grading step so that reach and time grading must be applied more conservatively.

- 1305 T1-1phase, delay for single phase faults: The Zone 1 is usually operated as fast tripping (instantaneous) underreach zone. For the fastest tripping all Zone 1 times are set to 0.00 s. For special applications, the trip time of single-phase faults may be set here to differ from that for multi-phase faults which is set below with parameter 1306.

- 1306 T1 multi-ph, delay for multi phase faults: Also here the zone 1 is usually operated as fast tripping (instantaneous) underreach zone. For the fastest tripping all Zone 1 times are set to 0.00 s. Refer also to setting 1305 above.

- 1315 T2-1phase, delay for single phase faults: For the Zone 2 and higher zones the co-ordination time must be calculated. This time must ensure that time graded tripping remains selective.

In Fig. 25 the parameters that need to be considered for the time grading margin are shown. The values entered apply for this example and correspond to the worst case conditions. The required time grading margin is therefore 250 ms. The Zone 2 is graded with the Zone 1 at the remote feeders so that a single time grading step is required (refer to Table 1). Set this time for single-phase faults to 0.25 s. For special applications, the trip time of single-phase faults may be set here to differ from that for multi-phase faults which is set below with parameter 1316.

- 1316 T2 multi-ph, delay for multi phase faults: As the Zone 2 will only trip three-pole in this example, and no special consideration is given to single-phase faults, this time is set the same as 1315 above to 0.25 s.

- 1325 T3 delay: From Table 1, the required time delay for this stage is two time steps = 0.50 s.

- 1335 T4 delay: From Table 1, this stage is not required so the time delay can be set to infinity,  $\infty$  s.

- 1345 T5 delay: From Table 1, the required time delay for this stage is three time steps = 0.75 s.

- 1355 T1B-1phase, delay for single ph. faults: The zone Z1B will be used for the teleprotection in a POTT scheme. For this application no time delay is required so the setting here is 0.00 s. For special applications, the trip time of single-phase faults may be set here to differ from that for multi-phase faults which is set below with parameter 1356.



1356 T1B-multi-ph, delay for multi ph. faults:  
As stated above the Zone Z1B will be used for the teleprotection in a POTT scheme. For this application no time delay is required so the setting here is 0.00 s.

■ 11. Distance zones (quadrilateral) – Setting Group A

11.1 Zone Z1

1301 Operating mode Z1:

In the case of quadrilateral distance protection zones, the user may select the operating mode for each zone as either “forward”, “reverse”, “non-directional” or “inactive”. When the zone is “inactive”, it does not produce any pickup signals or trip. The other options can be seen in the adjacent diagram where Z1, Z1B, Z2 and Z4 are set in the forward direction. Z3 is set in the reverse direction and Z5 is set non-directional. In this example, Zone 1 must be set in the forward direction.

1302 R(Z1), Resistance for ph-ph faults:

As the distance protection is applied with polygonal (quadrilateral) tripping characteristics, the zone limits are entered as resistance (R) and reactance (X) settings. A separate resistance reach setting is available for ph-ph measured loops and ph-e measured loops. This setting is for the ph-ph loops. With setting “1211 Angle of inclination, distance charact.” the polygon R-reach is inclined such that it is parallel to the line impedance (refer to Figure 12). The resistance settings of the individual zones therefore only have to cover the fault resistance at the fault location. For the Zone 1 setting only arc faults will be considered. For this purpose the arc resistance will be calculated with the following equation:

$$R_{arc} = \frac{U_{arc}}{I_F}$$

The arc voltage ( $U_{arc}$ ) will be calculated using the following rule of thumb which provides a very conservative estimate (the estimated  $R_{arc}$  is larger than the actual value):

$$U_{arc} = 2500 \text{ V} \cdot I_{arc} \text{ whereby } I_{arc} \text{ is the length of the arc.}$$

The length of the arc is greater than the spacing between the conductors (ph-ph), because the arc is blown into a curve due to thermal and magnetic forces. For estimation purposes it is assumed that  $I_{arc}$  is twice the conductor spacing.

Settings:		
No.	Settings	Value
1301	Operating mode Z1	Forward
1302	R(Z1), Resistance for ph-ph-faults	2,830 Ohm
1303	X(Z1), Reactance	3,537 Ohm
1304	RE(Z1), Resistance for ph-e faults	2,830 Ohm
1305	T1-1phase, delay for single phase faults	0,00 sec
1306	T1multi-ph, delay for multi phase faults	0,00 sec
1307	Zone Reduction Angle (load compensation)	15°

Fig. 26 Distance zone settings (Zone 1)

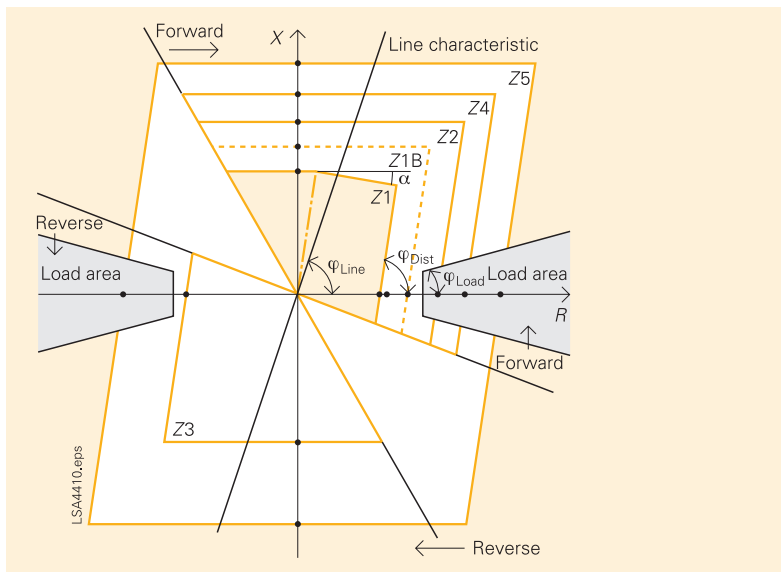

Fig. 27 Quadrilateral zone diagram

To obtain the largest value of  $R_{arc}$ , which is required for the setting, the smallest value of fault current must be used (calculated in Chapter 3):

$$R_{arc} = \frac{2500 \text{ V} \cdot 2 \cdot 5 \text{ m}}{1967 \text{ A}} = 12.7 \Omega$$

By addition of a 20 % safety margin and conversion to secondary impedance (factor from Table 2) the following minimum setting is calculated (division by 2 because  $R_{arc}$  appears in the loop measurement while the setting is done as phase impedance or positive sequence impedance):

$$R(Z1) = \frac{1.2 \cdot 12.7 \cdot 0.2632}{2} = 2.01 \Omega \text{ (sec.)}$$

This calculated value corresponds to the smallest setting required to obtain the desired arc resistance coverage. Depending on the X(Z1) reach calculated (see next page), this setting may be increased to obtain the desired Zone 1 polygon symmetry.

Therefore, looking ahead at the setting result for “1303 X(Z1), Reactance” below, we see that 3.537 Ohm are applied. For overhead line protection applications, the following rule of thumb may be used for the R(Z1) setting:

$$0.8 \cdot X(Z1) < R(Z1) < 2.5 \cdot X(Z1)$$

In this example the lower limit applies, so the setting for R(Z1) is:

$$R(Z1) = 0.8 \cdot 3.537 = 2.830 \Omega \text{ (sec.)}$$

This setting is then applied, **2.830 Ω**.

1303 X(Z1), Reactance:

The reactance reach is calculated based on the distance reach that this zone must provide. In Table 1 the reach of Zone 1 is specified as 80 % of Line 1. Therefore:

$$X(Z1) = 0.8 \cdot X_{\text{Line 1}}$$

$$X(Z1) = 0.8 \cdot 80 \cdot 0.021 = 13.44 \Omega \text{ (prim.)}$$

This is converted to a secondary value by multiplying with the conversion factor in Table 2:

$$X(Z1) = 13.44 \cdot 0.2632 = 3.537 \Omega \text{ (s)}$$

This setting is then applied, **3.537 Ω**.

1304 RE(Z1), Resistance for ph-e faults:

The phase to earth fault resistance reach is calculated along the same lines as the “1302 R(Z1)” setting for ph-ph faults. For the earth fault however, not only the arc voltage must be considered, but also the tower footing resistance. From the graph in Figure 29 it is apparent that although the individual tower footing resistance is 15 Ω (Table 2) the resultant value due to the parallel connection of multiple tower footing resistances is less than 1.5 Ω.

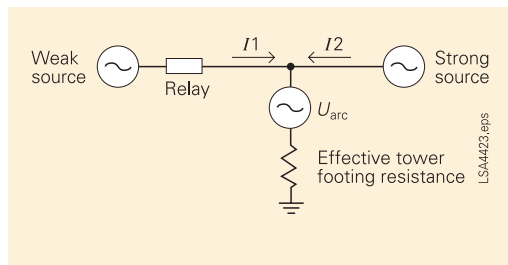

Fig. 28 Combination of arc voltage and tower footing resistance

From Fig. 28 it can be seen that the remote infeed ( $I_2$ ) will introduce an additional voltage drop across the “effective tower footing resistance” which will be measured in the fault loop by the relay (this effect is also shown in Figure 23).

To compensate for this influence, the maximum value (for practical purposes) of the ratio of  $I_2/I_1$  is required. This is given in Table 2 as the value 3. The maximum tower footing resistance that is measured by the relay in the fault loop is therefore:

$$R_{\text{TF}} = \left(1 + \frac{I_2}{I_1}\right) \cdot \text{effective tower footing R}$$

$$R_{\text{TF}} = (1 + 3) \cdot 1.5 = 6 \Omega \text{ (prim.)}$$

The arc voltage for the earth faults is calculated as follows using the conductor to tower/ground spacing given in Table 2:

$$U_{\text{arc}} = 2500 \text{ V} \cdot I_{\text{arc}}$$

$$U_{\text{arc}} = 2500 \text{ V} \cdot 2 \cdot 3 \text{ m} = 15 \text{ kV}$$

To obtain the largest value of  $R_{\text{arc}}$ , which is required for the setting, the smallest value of fault current must be used (calculated in Chapter 3):

$$R_{\text{arc}} = \frac{15 \text{ kV}}{1380 \Omega} = 10.9 \Omega$$

The total resistance that must be covered during earth faults is the sum of  $R_{\text{arc}}$  and  $R_{\text{TF}}$ . A safety factor of 20 % is included and the result is converted to secondary values (division by factor  $(1 + RE/RL)$ , because  $R_{\text{arc}}$  and  $R_{\text{TF}}$  appear in the loop measurement while the setting is done as phase impedance or positive sequence impedance):

$$RE(Z1) = \frac{1.2 \cdot (10.9 + 6) \cdot 0.2632}{(1 + 1.4)} = 2.22 \Omega \text{ (sec.)}$$

This calculated value corresponds to the smallest setting required to obtain the desired resistance coverage. Depending on the X(Z1) reach calculated above, this setting may be increased to obtain desired Zone 1 polygon symmetry. The setting result for “1303 X(Z1), Reactance” is 3.537 Ω. For overhead line protection applications, the following rule of thumb may be used for the RE(Z1) setting; note that the lower limit is the same as for ph-ph faults – this ensures fast Zone 1 tripping, while the upper limit is based on the loop reach – this avoids overreach:

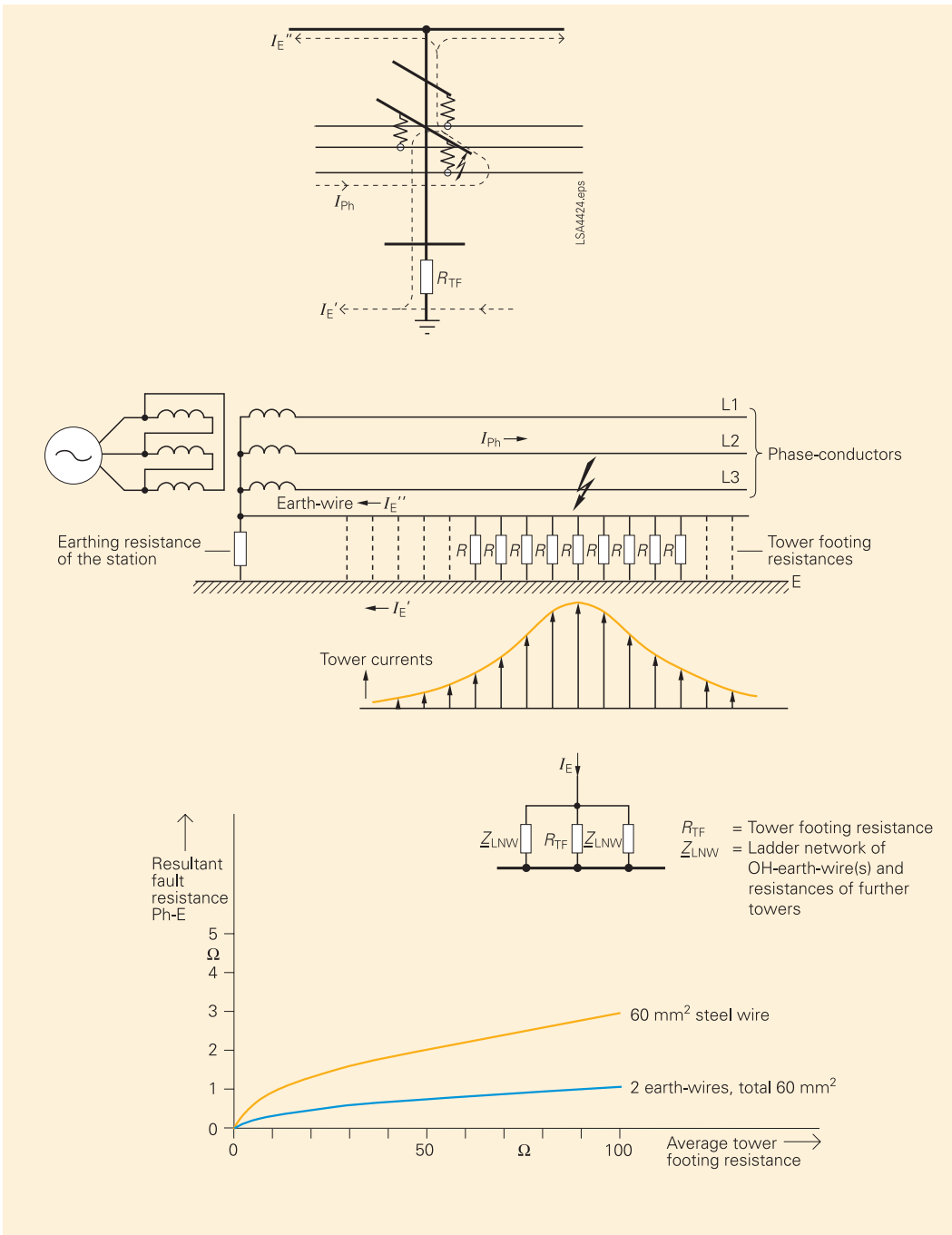

Fig. 29 Effective tower footing resistance

$$0.8 \cdot X(Z1) < RE(Z1) < \frac{1 + \frac{XE}{XL}}{1 + \frac{RE}{RL}} \cdot 2.5 \cdot X(Z1)$$

In this example the lower limit applies, so the setting for  $RE(Z1)$  is:

$$RE(Z1) = 0.8 \cdot 3.537 = 2.83 \Omega(\text{sec.})$$

This setting is then applied, 2.83 Ω.

- 1305 T1-1phase, delay for single phase faults:  
The Zone 1 is required to trip as fast as possible, therefore this time is set to **0.00 s**.
- 1306 T1 multi-ph, delay for multi phase faults:  
The Zone 1 is required to trip as fast as possible, therefore this time is set to **0.00 s**.
- 1307 Zone Reduction Angle (load compensation):  
The Zone 1 may under no circumstances operate for external faults as this would mean a loss of selectivity. The influence of remote infeed in conjunction with fault resistance must be considered in this regard. From the voltage and current phasors in Fig. 30 the influence of the transmission angle (TA), i.e. angle between the voltages  $V_A$  and  $V_B$ , on the measured fault resistance can be seen. In the impedance plane the phasor  $I_2/I_1 R_F$  is rotated downwards by the transmission angle. The risk of the external fault encroaching into Zone 1 is shown. To prevent this, the Zone 1 X setting characteristic is tilted downwards by the "Alpha angle". A detailed calculation of the "Alpha angle" is complicated and heavily dependant on changing system conditions. A worst practical case is therefore selected to fix the "Alpha angle" setting. For this purpose the largest transmission angle that can occur in the system during normal overload conditions must be applied to the following set of curves.

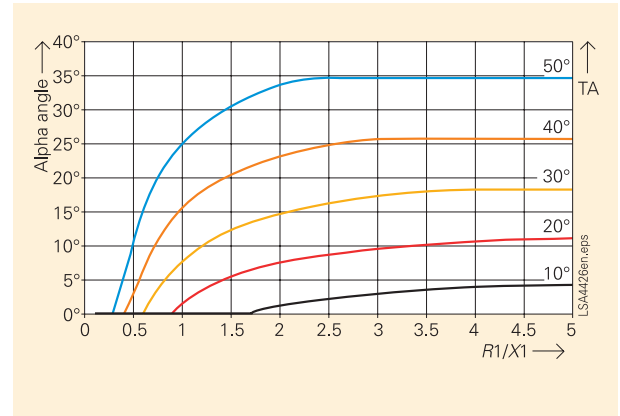

Fig. 31 Curves for selection of Alpha angle setting

From Table 2 the maximum "Transmission Angle" for this application is given as  $35^\circ$ . If this is checked in Figure 31 together with the  $R1/X1$  setting value of 0.8 (see above  $2.830/3.537 = 0.8$ ), then the required "Alpha Angle" setting is less than  $15^\circ$  (by using the  $TA = 40$  curve). A setting of  $15^\circ$  is therefore applied.

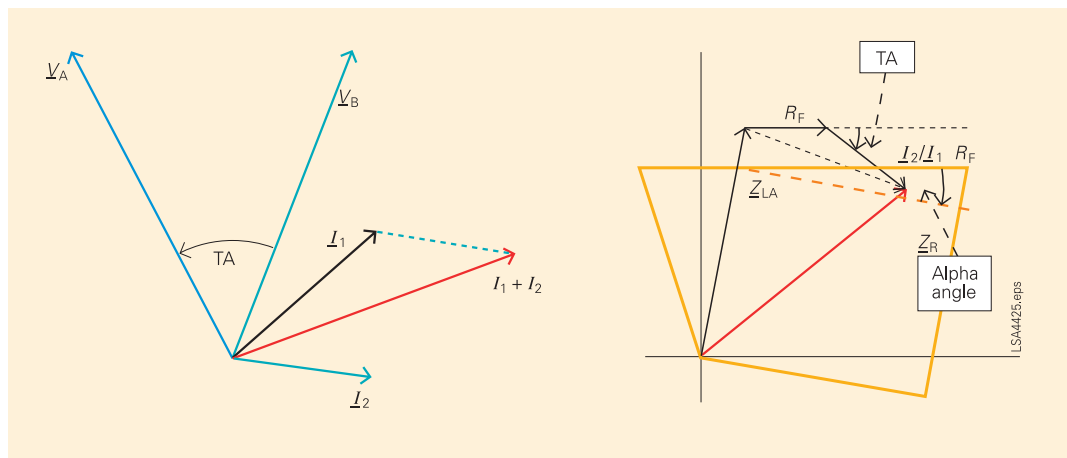

Fig. 30 Transmission angle for Alpha angle setting

## 11.2 Zone Z1B

### 1351 Operating mode Z1B (overreach zone):

The Zone Z1B will be used for the teleprotection scheme POTT in this application. For this the Zone Z1B must be applied as **forward** overreach zone.

### 1352 R(Z1B), Resistance for ph-ph faults:

As was the case for the Zone 1 settings, this setting must cover all internal arc faults. The minimum setting therefore equals the R(Z1) setting, 2.830 Ω. However, additional reach is set for the Z1B compared to Z1, because this is an overreach zone while Z1 is set to underreach. The amount of additional R reach mainly depends on the ratio of R reach to X reach setting. For the Zone Z1B the following limit is recommended:

$$X(Z1B) < R(Z1) < 4 \cdot X(Z1)$$

Looking ahead at the applied setting for “1353 X(Z1B), Reactance” which is 6.633 Ohm, it is apparent that the lower limit will apply. The setting of R(Z1B) therefore also is 6.633 Ω.

### 1353 X(Z1B), Reactance:

The Zone Z1B must be set to overreach Line 1. The minimum setting is 120 % of the line reactance. In practice, however, a setting of 150 % or greater is applied unless the line in question is extremely long.

The risk of underreach due to the effects shown in Figs. 21, 23 and 30 are then avoided. For this application, medium length line, a reach of 150 % is selected:

$$X(Z1B) = 1.5 \cdot X_{\text{Line 1}}$$

$$X(Z1B) = 1.5 \cdot 80 \cdot 0.21 = 25.2 \text{ } \Omega \text{ (prim.)}$$

The applied setting therefore is:

$$X(Z1B) = 25.2 \text{ } \Omega \text{ (prim.)} \cdot 0.2632$$

$$X(Z1B) = 6.633 \text{ } \Omega \text{ (sec.)}$$

6.633 Ω.

Distance zones (quadrilateral) - Settings Group A					
Zone Z1	Zone Z1B-exten.	Zone Z2	Zone Z3	Zone Z4	Zone Z5
Settings:					
No.	Settings	Value			
1351	Operating mode Z1B (overreach zone)	Forward			
1352	R(Z1B), Resistance for ph-ph-faults	1,500 Ohm			
1353	X(Z1B), Reactance	3,000 Ohm			
1354	RE(Z1B), Resistance for ph-e faults	3,000 Ohm			
1355	T1B-1phase, delay for single ph. faults	0,00 sec			
1356	T1B-multi-ph, delay for multi ph. faults	0,00 sec			
1357	Z1B enabled before 1st AR (int. or ext.)	NO			

Fig. 32 Settings for Zone Z1B

### 1354 RE(Z1B), Resistance for ph-e faults:

As was the case for the Zone 1 settings, this setting must cover all internal arc faults. The minimum setting therefore equals the RE(Z1) setting, 2.83 Ohm. As described for setting “1352 R(Z1B)” additional reach is usually applied and the following rule of thumb is used for the RE(Z1B) setting:

$$1 + \frac{XE}{XL} \cdot X(Z1B) < RE(Z1B) < \frac{1 + \frac{XE}{XL}}{1 + \frac{RL}{RE}} \cdot 4 \cdot X(Z1B)$$

In this example the lower limit applies, so the setting for RE(Z1B) is:

$$RE(Z1B) = \frac{(1+1.07)}{(1+1.38)} \cdot 6.633 = \underline{\underline{5.769 \text{ } \Omega \text{ (sec.)}}}$$

This setting is then applied, 5.769 Ω.

### 1355 T1B-1phase, delay for single ph. faults:

In this POTT scheme both single and multi-phase faults must be tripped without additional delay. The setting 0.00 s is therefore applied.

### 1356 T1B-multi-ph, delay for multi ph. faults:

In this POTT scheme both single and multi-phase faults must be tripped without additional delay. The setting 0.00 s is therefore applied.

### 1357 Z1B enabled before 1st AR (int. or ext.):

This setting was already applied in Chapter 10.1 and is repeated here with the other Z1B settings. The setting is NO.



11.3 Zone Z2

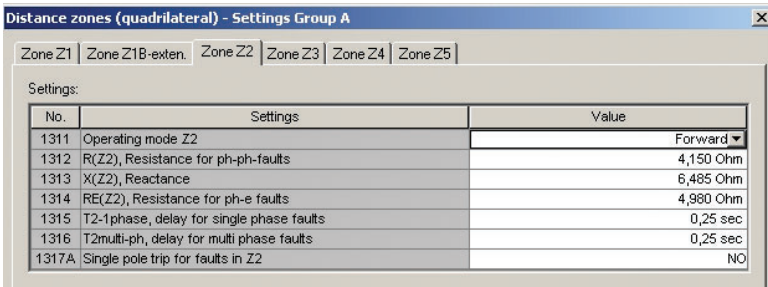

No.	Settings	Value
1311	Operating mode Z2	Forward
1312	R(Z2), Resistance for ph-ph-faults	4,150 Ohm
1313	X(Z2), Reactance	6,485 Ohm
1314	RE(Z2), Resistance for ph-e faults	4,980 Ohm
1315	T2-1phase, delay for single phase faults	0,25 sec
1316	T2multi-ph, delay for multi phase faults	0,25 sec
1317A	Single pole trip for faults in Z2	NO

Fig. 33 Settings for Zone Z2

- 1311 Operating mode Z2:  
The Zone Z2 is used as the first overreaching time graded zone. It must therefore be applied in the **forward** direction.
- 1312 R(Z2), Resistance for ph-ph faults:  
Resistance coverage for all arc faults up to the set reach (refer to Table 1) must be applied. As this zone is applied with overreach, an additional safety margin is included, based on a minimum setting equivalent to the X(Z2) setting and arc resistance setting for internal faults, R(Z1) setting. Looking ahead, X(Z2) is set to **6.485 Ω**. Therefore:

$$R(Z2)_{min} = \frac{X(Z2)}{X_{Line1}(s)} \cdot R(Z1)$$

$$R(Z2)_{min} = \frac{6.485}{80 \cdot 0.21 \cdot 0.2632} \cdot 2.83 = \underline{\underline{4.15 \Omega(sec.)}}$$

The setting of R(Z2) therefore is **4.150 Ω**.

- 1313 X(Z2), Reactance:  
According to the grading requirement in Table 1:

$$X(Z2) = 0.8 \cdot (X_{Line1} + 0.8 \cdot X_{Line3}) \cdot \frac{CTratio}{VTratio}$$

$$X(Z2) = 0.8(80 \cdot 0.21 + 0.8 \cdot 17.5) \cdot 0.2632$$

$$X(Z2) = \underline{\underline{6.485 \Omega(sec.)}}$$

The applied setting therefore is **6.485 Ω**.

- 1314 RE(Z2), Resistance for ph-e faults:  
Similar to the R(Z2) setting, the minimum required reach for this setting is based on the RE(Z1) setting which covers all internal fault resistance and the X(Z2) setting which determines the amount of overreach. Alternatively, the RE(Z2) reach can be calculated from the R(Z2) reach with the following equation:

$$RE(Z2) = \frac{X(Z2)}{X_{Line1}(sec.)} \cdot RE(Z1) \cdot 1.2$$

$$RE(Z2) = \frac{6.485}{80 \cdot 0.21 \cdot 0.2632} \cdot 2.83 \cdot 1.2 = \underline{\underline{4.98 \Omega(sec.)}}$$

This setting is then applied, **4.98 Ω**.

- 1315 T2-1phase, delay for single phase faults:  
This setting was already applied in Chapter 10.3 and is shown here again with all the Zone 2 settings. The setting **0.25 s** is applied.
- 1356 T2-multi-ph, delay for multi phase faults:  
This setting was already applied in Chapter 10.3 and is shown here again with all the Zone 2 settings. The setting **0.25 s** is applied.
- 1317A Single pole trip for faults in Z2:  
This setting was already applied in Chapter 10.1 and is shown here again with all the Zone 2 settings. The setting **NO** is applied.

11.4 Zone Z3

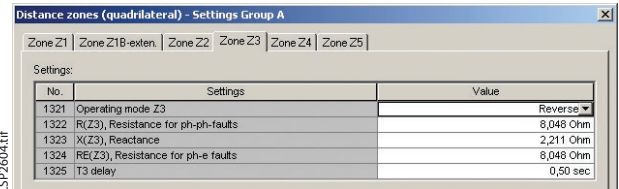

No.	Settings	Value
1321	Operating mode Z3	Reverse
1322	R(Z3), Resistance for ph-ph-faults	6,048 Ohm
1323	X(Z3), Resistance	2,211 Ohm
1324	RE(Z3), Resistance for ph-e faults	6,048 Ohm
1325	T3 delay	0,50 sec

Fig. 34 Settings for Zone Z3

- 1321 Operating mode Z3:  
Zone Z3 is used as reverse time delayed back-up stage (refer to Table 1). It must therefore be set in the **reverse** direction.
- 1322 R(Z3), Resistance for ph-ph faults:  
Resistance coverage settings for backup protection with distance protection zones is defined by a lower limit and upper limit. The lower limit is the minimum fault resistance (arc resistance) that must be covered, and the upper limit is based on the corresponding X reach setting. Note that for high resistance faults (not arc faults), the other infeeds to the reverse fault cause severe underreach.  
As no detailed values are available, it is safe to assume that the required arc resistance coverage is the same as that calculated for faults on Line 1. Therefore the setting for R(Z1), 2.830 Ω, defines the lower limit. The upper limit is given by reach symmetry constraints and states that R(Z3) < 6 times X(Z3). Looking ahead, X(Z3) is set to 2.211 Ω, so the upper limit is 13.266 Ω. A setting halfway between these limits is a safe compromise:

$$R(Z3) = \frac{R(Z1) + 6 \cdot X(Z3)}{2}$$

$$R(Z3) = \frac{2.83 + 6 \cdot 2.211}{2} = \underline{\underline{8.048 \Omega(\text{sec.})}}$$

The applied setting therefore is **8.048 Ω**.

- 1323 X(Z3), Reactance:  
According to the grading requirement in Table 1:

$$X(Z3) = 0.5 \cdot X_{Line1} \cdot \frac{CTratio}{VTratio}$$

$$X(Z3) = 0.5 \cdot 80 \cdot 0.211 \cdot 0.2632 = \underline{\underline{2.211 \Omega(\text{sec.})}}$$

The applied setting therefore is **2.211 Ω**.

- 1324 RE(Z3), Resistance for ph-e faults:  
Similar to the R(Z3) setting, the upper and lower limits are defined by minimum required reach and symmetry. In this application set the RE(Z3) reach the same as R(Z3) to **8.048 Ω**.

- 1325 T3 delay:  
This setting was already applied in Chapter 10.3 and is shown here again with all the Zone 3 settings. The setting **0.50 s** is applied.

### 11.5 Zone Z4

No.	Settings	Value
1331	Operating mode Z4	Inactive
1332	R(Z4), Resistance for ph-ph-faults	12,000 Ohm
1333	X(Z4), Reactance	12,000 Ohm
1334	RE(Z4), Resistance for ph-e faults	12,000 Ohm
1335	T4 delay	∞ sec

Fig. 35 Settings for Zone Z4

- 1331 Operating mode Z4:  
Zone Z4 is not applied (refer to Table 1). It must therefore be set as **inactive** direction.  
Further settings in this block are of no consequence and therefore not discussed here.

### 11.6 Zone Z5

No.	Settings	Value
1341	Operating mode Z5	Non-Directional
1342	R(Z5), Resistance for ph-ph-faults	26,320 Ohm
1343	X(Z5)+, Reactance for Forward direction	17,782 Ohm
1344	RE(Z5), Resistance for ph-e faults	26,320 Ohm
1345	T5 delay	0,75 sec
1346	X(Z5)-, Reactance for Reverse direction	8,891 Ohm

Fig. 36 Settings for Zone Z5

- 1341 Operating mode Z5:  
Zone Z5 is used as non-directional final backup stage (refer to Table 1). It must therefore be set as **non-directional** zone.
- 1342 R(Z5), Resistance for ph-ph faults:  
Resistance coverage settings for backup protection with distance protection zones is defined by a lower limit and upper limit. The lower limit is the minimum fault resistance (arc resistance) that must be covered, and the upper limit is based on the corresponding X reach setting. Note that for high resistance faults (not arc faults), the other infeeds to the reverse fault cause severe underreach.  
As no detailed values are available, the required arc resistance coverage is calculated for the arc voltage (5 m) and 50 % of nominal current or 500 A primary.

$$R(Z5)_{\min} = \frac{2500 \text{ V} / \text{m} \cdot 2 \cdot 5 \text{ m}}{500 \text{ A}} \cdot \frac{CTratio}{VTratio}$$

$$R(Z5)_{\min} = \frac{2500 \cdot 2 \cdot 5}{500} \cdot 0.2632 = \underline{\underline{13.16 \Omega(\text{sec.})}}$$

This setting would ensure detection in Zone 5, if the arc voltage, as calculated in Chapter 11.1, is for 5 m conductor spacing and the fault current is at least 500 A. The upper limit is given by reach symmetry constraints and states that  $R(Z5) < 6$  times  $X(Z5) +$  or  $X(Z5) -$ . Looking ahead,  $X(Z5)$  is set to **17.782 Ω**, so the upper limit is **106.69 Ω**. This is far into the load area (refer to parameter 1241, calculated in Chapter 10.1). A setting of double the minimum is a safe compromise:

$$R(Z5) = R(Z5)_{\min} \cdot 2$$

$$R(Z5) = 13.16 \Omega \cdot 2 = \underline{\underline{26.32 \Omega}}$$

The applied setting therefore is **26.320 Ω**.

1343 X(Z5)+, Reactance for Forward direction:  
According to the grading requirement in Table 1:

$$X(Z5) = 1.2 \cdot (X_{Line1} + X_{Line2}) \cdot \frac{CTratio}{VTratio}$$

$$X(Z5) = 1.2 \cdot (80 \cdot 0.21 + 39.5) \cdot 0.2632$$

$$X(Z5) = 17.782 \Omega \text{ (sec.)}$$

The applied setting therefore is 17.782 Ω.

1344 RE(Z5), Resistance for ph-e faults:  
Similar to the R(Z5) setting, the upper and lower limits are defined by minimum required reach and symmetry. In this application set RE(Z5) reach to the same as R(Z5). The applied setting therefore is 26.32 Ω.

1345 T5 delay:  
This setting was already applied in Chapter 10.3 and is shown here again with all the Zone 5 settings. The setting 0.75 s is applied.

1346 X(Z5)-, Reactance for Reverse direction:  
For non-directional Zone Z5 the following symmetry requirement can be applied, if no other conditions are specified:

$$0.5 \cdot X(Z5)+ < X(Z5)- < 2 \cdot X(Z5)+$$

In this case the lower limit will apply so that:

$$X(Z5)- = 0.5 \cdot X(Z5)+$$

$$X(Z5)- = 0.5 \cdot 17.782$$

$$X(Z5)- = 8.891 \Omega \text{ (sec.)}$$

The applied setting therefore is 8.891 Ω.

### ■ 12. Power swing – Setting Group A

No.	Settings	Value
2002	Power Swing Operating mode	all zones blocked
2006	Power swing trip	NO
2007	Trip delay after Power Swing Blocking	0,08 sec

Fig. 37 Power swing settings

2002 Power Swing Operating mode:  
In the event of a power swing, tripping by the distance protection due to the measurement of the “swing impedance” must be prevented. The setting all zones blocked is therefore applied.

2006 Power swing trip:  
When the power swing is severe and an out of step condition is reached, selective power swing tripping should be applied in the system to obtain stable islanded subsystems. This relay is not positioned on such an interconnection so out of step tripping is not required, therefore setting is NO.

2007 Trip delay after Power Swing Blocking:  
If during a power swing, which is detected by the relay, an external switching operation takes place, a jump of the measured “swing impedance” takes place. This jump can reset the power swing detection. To prevent tripping, if this impedance is inside the protected zones, a delay time of 0.08 s is set to allow the power swing measurement to securely pick up again.

### ■ 13. Teleprotection for distance protection – Setting Group A

No.	Settings	Value
2101	Teleprotection for Distance prot. is	ON
2102	Type of Line	Two Terminals
2103A	Time for send signal prolongation	0,05 sec
2109A	Transient Block: Duration external fit.	0,04 sec
2110A	Transient Block: Blk.T. after ext. fit.	0,05 sec

Fig. 38 Teleprotection for distance protection settings

2101 Teleprotection for Distance prot. is:  
In this application the teleprotection is ON.

2102 Type of Line:  
The line is a two terminal line.

2103A Time for send signal prolongation:  
In the event of sequential operation at the two line ends or very slow operation at one end, the end that trips first may reset and stop transmitting the send signal before the slow end is ready to operate. The send signal prolongation time ensures that the trip signal only resets once the remote end has had sufficient time to pickup.

In Figure 39 the delayed pickup of the remote end, after opening of the local circuit-breaker, must be considered to ensure that the send signal is not reset too soon. Channel timing is neglected as it adds on to the safety margin. The times indicated in the drawing apply in this example so that a setting of **0.05 s** is applied.

- 2109A Transient Block.: Duration external flt:  
The transient blocking, also referred to as current reversal guard, is required with the POTT scheme, if parallel circuits are present. During clearance of a fault on the parallel circuit, the fault current may reverse on the protected circuit. To avoid operation of the POTT scheme under these conditions, the transient blocking times are applied. To ensure that transient blocking is only activated by external faults, it only starts following reverse fault detection for this time which is set to 80 % of the fastest fault clearance on the parallel circuit (including CB operation).

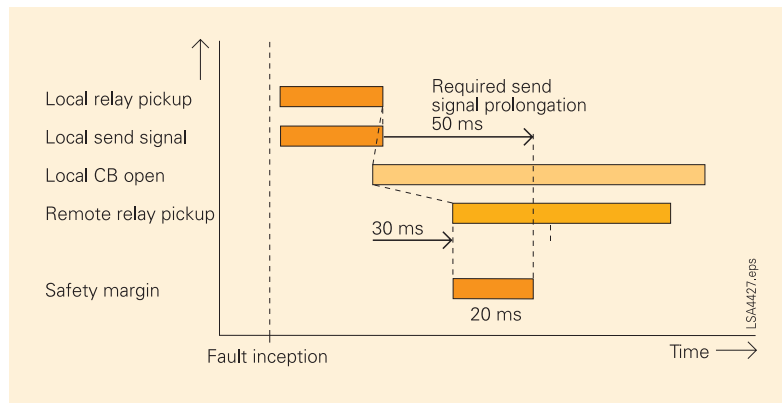

Fig. 39 Time chart to send signal prolongation time

No.	Settings	Value
2501	Weak Infeed function is	Echo and Trip
2502A	Trip / Echo Delay after carrier receipt	0,04 sec
2503A	Trip Extension / Echo Impulse time	0,05 sec
2504A	Echo Block Time	0,05 sec
2505	Undervoltage (ph-e)	25 V
2509	Echo logic: Dis and EF on common channel	NO

Fig. 40 Weak infeed settings

$$T_w = 0.8 \cdot (T_{\text{circuit\_breaker}} + T_{\text{relay\_parallel\_Line}} - T_{\text{relay\_protected\_Line}})$$

$$T_w = 0.8 \cdot (60 \text{ ms} + 10 \text{ ms} - 20 \text{ ms}) = \underline{\underline{40 \text{ ms}}}$$

The setting **0.04 s** is applied.

- 2110A Transient Block.: Blk. T. after ext. flt:  
Following clearance of the external fault, the transient blocking condition must be maintained until both line ends securely detect the new fault condition. For this purpose the relay pickup time (re-orientation) and channel delay time must be considered.

$$T_b = 1.2 \cdot (T_{\text{channel\_delay}} + T_{\text{relay\_re-orientation}})$$

$$T_b = 1.2(20 \text{ ms} + 20 \text{ ms}) = \underline{\underline{48 \text{ ms}}}$$

The setting **0.05 s** is applied.

#### ■ 14. Weak infeed (trip and/or echo) – Setting Group A

- 2501 Weak Infeed function is:  
When the POTT teleprotection scheme is used, the weak infeed function can be applied for fast fault clearance at both line ends even if one line end has very weak or no infeed. The weak infeed function must be activated at the line end where a weak infeed can occur. If a strong infeed is assured at all times, this function can be switched off. The function may also be used to only send an echo back to the strong infeed, so that it can trip with the POTT scheme, or to trip at the weak infeed

end in addition to sending the echo. In this application both **Echo and Trip** will be used.

- 2502A Trip /Echo Delay after carrier receipt:  
As the communication channel may produce a spurious signal (unwanted reception), a small delay is included for security purposes. Only if the receive signal is present for this time will the weak infeed function respond. In the event of 3-pole open condition of the circuit-breaker, this time delay is bypassed and the echo is sent immediately. The default setting of **0.04 s** is appropriate for this application.
- 2503A Trip Extension / Echo Impulse time:  
To ensure that the echo signal can be securely transmitted, it must have a defined minimum length. On the other hand, a permanent echo signal is not desired. Therefore the echo is sent as a pulse with this set length. If tripping is also applied, then this time also defines the length of the internal trip signal (refer also to parameter 240 A in Chapter 7.3). The default setting of **0.05 s** is appropriate for this application.

- 2504A Echo Block Time:  
If weak infeed echo is applied at both line ends, then it must be avoided that a received echo signal is again sent as echo in a continuous stream of echo signals. For this purpose, this blocking time is set to prevent a new weak infeed operation before it expires. A secure setting of this timer is the time required for a signal to be transmitted from one end to the other and back again (twice the channel delay time) plus a safety margin of 10 ms. In this application, a worst channel delay time of 20 ms is assumed so that a setting of 0.05 s is appropriate.
- 2505 Undervoltage (ph-e):  
The weak infeed trip signal (phase selective) is supervised by this undervoltage threshold. At the weak infeed end the source impedance is very large so that very small voltages are measured during faults on the protected circuit. If this threshold is set well below the minimum operational ph-e voltage then weak infeed tripping is secure and phase selective. Simulations and practical experience have shown that a setting of 50 % nominal ph-e voltage provides good results. The default setting of 25 V is therefore applied.

- 2509 Echo Logic: Dis and EF on common channel:  
If the distance protection and directional earth-fault protection are both applied with teleprotection (Distance with POTT and EF with directional comparison) the signals can be routed via one common channel or via two separate channels in the communication system. The weak infeed and echo logic must be set accordingly to ensure correct response. In this application, two separate channels are used so the setting is NO.

■ 15. Backup overcurrent – Setting Group A  
15.1 General

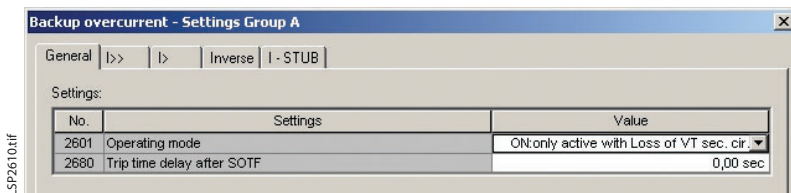

Fig. 41 General settings, backup overcurrent

- 2601 Operating mode:  
The distance protection is more selective and more sensitive than the overcurrent protection. The overcurrent protection is therefore only required when the distance protection is blocked due to failure of the voltage measuring circuit (emergency mode). Therefore the operating mode is set to ON: only active with loss of VT sec. cir.
- 2680 Trip time delay after SOTF:  
Following line closure detection the “Switch On To Fault” function is activated (refer to parameters 1132A and 1134 in Chapter 9.2). The backup overcurrent stages may also be used for SOTF tripping. This timer sets the time delay for SOTF trip with a backup overcurrent. In this application SOTF with backup overcurrent is not applied so the setting of this timer is not relevant; leave the default value of 0.00 s.

15.2 I>> stage

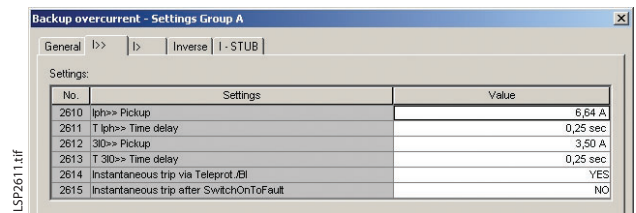

Fig. 42 I>> stage settings, backup overcurrent

- 2610 I<sub>ph>></sub> Pickup:  
This high set stage is required to trip with single time step grading. It should therefore have a reach equivalent to the Zone 2 setting. The setting should therefore be equal to the maximum 3-phase fault current for a fault at the Zone 2 reach setting.  
Based on the source and line impedances, the following maximum fault current level can be calculated for faults at the Zone 2 reach limit:

$$I_{\text{fault}} = \frac{U_{\text{source}}}{\sqrt{3} \cdot Z_{\text{tot}}} \quad \text{with } U_{\text{source}} = 400 \text{ kV}$$

Z<sub>tot</sub> = sum of minimum positive sequence source and line impedance up to Zone 2 reach (as only current magnitudes are being calculated, only the magnitude of the impedance is relevant)



$$|Z_{\text{tot}}| = |(R_{\text{source\_min}} + 0.8 \cdot (R_{\text{Line1}} + 0.8 \cdot R_{\text{Line2}})) + j(X_{\text{source\_min}} + 0.8 \cdot (X_{\text{Line1}} + 0.8 \cdot X_{\text{Line2}}))|$$

$$|Z_{\text{tot}}| = |(1 + 0.8 \cdot (80 \cdot 0.025 + 0.8 + 1.5)) + j(10 + 0.8 \cdot (80 \cdot 0.21 + 0.8 \cdot 17.5))|$$

$$|Z_{\text{tot}}| = |3.56 + j34.64|$$

$$|Z_{\text{tot}}| = 34.8$$

The maximum three-phase fault current at the Zone 2 reach limit therefore is:

$$I_{3\text{ph Z2max}} = \frac{400 \text{ kV}}{\sqrt{3} \cdot 34.8} = \underline{\underline{6636 \text{ A}}}$$

As a secondary value, the setting applied for  $I_{>>}$  is therefore **6.64 A**.

2611  $T I_{\text{ph}>>}$  Time delay:

This high set stage is required to trip with single time step grading. Therefore set **0.25 s** which is one time step (refer to Fig. 25).

2612  $3I_{0>>}$  Pickup:

This high set stage is required to trip earth faults with single time step grading. It should therefore have a reach equivalent to the Zone 2 setting. The setting should therefore be equal to the maximum single-phase fault current for a fault at the Zone 2 reach setting.

Based on the source and line impedances, the following maximum fault current level can be calculated for faults at the Zone 2 reach limit:

$$I_{\text{fault}} = \frac{U_{\text{source}}}{\sqrt{3} \cdot Z_{\text{tot}}} \quad \text{with} \quad U_{\text{source}} = 400 \text{ kV}$$

$Z_{\text{tot}} = 1/3$  of the sum of minimum positive, negative and zero sequence source and line impedance up to Zone 2 reach (as only current magnitudes are being calculated, only the magnitude of the impedance is relevant)

For the 3-phase fault level used in setting 2610, the total positive sequence impedance was calculated. As the negative sequence impedance equals the positive sequence value, the  $Z_{\text{tot}}$  for this setting can be calculated as follows:

$$|Z_{\text{tot}}| = \frac{|2 \cdot Z_{\text{tot\_2610}} + (R_{0\text{ source\_min}} + 0.8 \cdot (R_{0\text{ Line1}} + 0.8 \cdot R_{0\text{ Line2}})) + j(X_{0\text{ source\_min}} + 0.8 \cdot (X_{0\text{ Line1}} + 0.8 \cdot X_{0\text{ Line2}}))|}{3}$$

$$|Z_{\text{tot}}| = \frac{|(7.12 + 2.5 + 0.8 \cdot (80 \cdot 0.13 + 0.8 \cdot 7.5)) + j(69.28 + 20 + 0.8 \cdot (80 \cdot 0.81 + 0.8 \cdot 86.5))|}{3}$$

$$|Z_{\text{tot}}| = |7.58 + j65.49|$$

$$|Z_{\text{tot}}| = 65.9$$



The maximum single-phase fault current at the Zone 2 reach limit therefore is:

$$I_{3\text{ph } Z2\text{max}} = \frac{400 \text{ kV}}{\sqrt{3} \cdot 65,9} = \underline{\underline{3504 \text{ A}}}$$

As a secondary value, the setting applied for  $3I_{0>>}$  is therefore **3.50 A**.

- 2613  $T 3I_{0>>}$  Time delay:  
This high set stage is required to trip with single time step grading. Therefore set **0.25 s** which is one time step (refer to Fig. 25).
- 2614 Instantaneous trip via Teleprot./BI:  
The backup overcurrent is only active when the distance protection is blocked due to failure of the secondary VT circuit (refer to setting 2601 in Chapter 15.1). If under these conditions a teleprotection signal is received from the remote end, the tripping of the overcurrent protection may be accelerated. This may be safely applied for this stage, because its reach is less than the set  $Z1B$ . Therefore apply the setting YES. Note that for this function to work, the binary input function “7110 >O/C InstTRIP” must be assigned in parallel to the teleprotection receive binary input of the distance protection.
- 2615 Instantaneous trip after SwitchOnToFault:  
This function is not applied (refer to setting 2680 in Chapter 15.1). Therefore NO is set.

As a secondary value, the setting applied for  $I>$  is therefore **1.74 A**.

- 2621  $T I_{\text{ph}}>$  Time delay:  
This stage is required to trip with the same time delay as Zone 5, three time grading steps. Therefore set **0.75 s** which is three time steps (refer to Fig. 25).
- 2622  $3I_{0>}$  Pickup:  
This stage is required to trip with time delay equal to Zone 5. It should detect earth faults with similar sensitivity as Zone 5. Therefore, with the weakest infeed according to Table 2, an earth fault at the X reach limit of Zone 5 will have the following current magnitude:

$$3I_{0Z5\_min} = \frac{U_{\text{nom\_sec}}}{\sqrt{3} \cdot (X_{\text{source\_max}} + X_{Z5\_sett}) \cdot \left(1 + \frac{XE}{XL}\right)}$$

$$3I_{0Z5\_min} = \frac{100}{\sqrt{3} \cdot (100 \cdot 0.2632 + 17.782) \cdot (1 + 1.38)}$$

$$3I_{0Z5\_min} = 0.55 \text{ A}$$

As a secondary value, the setting applied for  $3I_{0>}$  is therefore **0.55 A**.

- 2623  $T 3I_{0>>}$  Time delay:  
This high set stage is required to trip with three time grading steps. Therefore set **0.75 s** which is three time steps (refer to Fig. 25).
- 2624 Instantaneous trip via via Teleprot./BI:  
The  $I>>$  stage is applied for this purpose, refer to setting 2614 in Chapter 15.2. Therefore set **NO** for this stage.
- 2625 Instantaneous trip after SwitchOnToFault:  
This function is not applied (refer to setting 2680 in Chapter 15.1). Therefore **NO** is set.

### 15.3 I> stage

No.	Settings	Value
2620	$I_{\text{ph}}>$ Pickup	1,74 A
2621	$T I_{\text{ph}}>$ Time delay	0,75 sec
2622	$3I_{0>}$ Pickup	0,55 A
2623	$T 3I_{0>}$ Time delay	0,75 sec
2624	Instantaneous trip via Teleprot./BI	NO
2625	Instantaneous trip after SwitchOnToFault	NO

Fig. 43 I> stage settings, backup overcurrent

- 2620  $I_{\text{ph}}>$  Pickup:  
This stage is required to trip with time delay equal to Zone 5. It may not pick up due to load (permissible overload). The permissible overload is twice the full load, therefore:

$$I_{\text{ph}}> \text{ Pickup} \geq \frac{2 \cdot \text{Rated MVA}}{\sqrt{3} \cdot \text{Full scale voltage}}$$

$$I_{\text{ph}}> \text{ Pickup} \geq \frac{2 \cdot 600}{\sqrt{3} \cdot 400} = \underline{\underline{1732 \text{ A}}}$$

## 15.4 Inverse stage

No.	Settings	Value
2640	$I_p >$ Pickup	$\infty$ A
2642	T $I_p$ Time Dial	0,50 sec
2646	T $I_p$ Additional Time Delay	0,00 sec
2650	$3I_{0p}$ Pickup	$\infty$ A
2652	T $3I_{0p}$ Time Dial	0,50 sec
2656	T $3I_{0p}$ Additional Time Delay	0,00 sec
2660	IEC Curve	Normal Inverse
2670	Instantaneous trip via Teleprot./BI	NO
2671	Instantaneous trip after SwitchOnToFault	NO

Fig. 44 Inverse stage settings, backup overcurrent

2640  $I_p >$  Pickup:

The co-ordination of inverse time graded protection can be applied effectively to obtain reasonably fast and sensitive selective protection. In this application, the inverse stage is not used, so the setting here is infinity,  $\infty$  A.

2642 T  $I_p$  Time Dial:

As the setting of 2640 above is infinity ( $\infty$ ), this setting is not relevant and left on the default value of 0.50 s.

2646 T  $I_p$  Additional Time Delay:

This stage may also be used as a further definite time delay stage by using this setting. As the setting of 2640 above is infinity ( $\infty$ ), this setting is not relevant and left on the default value of 0.00 s.

2650  $3I_{0p}$  Pickup:

The co-ordination of inverse time graded protection can be applied effectively to obtain reasonably fast and sensitive selective protection. In this application, the inverse stage is not used, so the setting here is infinity,  $\infty$  A.

2652 T  $3I_{0p}$  Time Dial:

As the setting of 2650 above is infinity ( $\infty$ ), this setting is not relevant and left on the default value of 0.50 s.

2656 T  $3I_{0p}$  Additional Time Delay:

This stage may also be used as a further definite time delay stage by using this setting. As the setting of 2650 above is infinity ( $\infty$ ), this setting is not relevant and left on the default value of 0.00 s.

## 2660 IEC Curve:

During the device configuration (Chapter 4) the standard of the curves was selected with parameter 0126 to be IEC. Here the choice is made from the various IEC curves. As the stage is not applied in this application the setting is not relevant and left on the default value of Normal inverse.

## 2670 Instantaneous trip via Teleprot./BI:

The  $I >>$  stage is applied for this purpose, refer to setting 2614 in Chapter 15.2. Therefore set NO for this stage.

## 2671 Instantaneous trip after SwitchOnToFault:

This function is not applied (refer to setting 2680 in Chapter 15.1). Therefore NO is set.

## 15.5 I STUB stage

No.	Settings	Value
2630	$I_{ph} >$ STUB Pickup	$\infty$ A
2631	T $I_{ph}$ STUB Time delay	0,30 sec
2632	$3I_{0} >$ STUB Pickup	$\infty$ A
2633	T $3I_{0}$ STUB Time delay	2,00 sec
2634	Instantaneous trip via Teleprot./BI	NO
2635	Instantaneous trip after SwitchOnToFault	NO

Fig. 45 I STUB stage settings, backup overcurrent

2630  $I_{ph} >$  STUB Pickup:

This stage may be used as a normal definite time delay stage. In addition to this, it provides for blocking or release via binary input. For certain applications (e.g. 1 ½ CB) a STUB exists when the line isolator is open. By releasing this overcurrent stage via the mentioned binary inputs, a fast selective fault clearance for faults on the STUB can be obtained. In this application, no such STUB protection is required, so this stage is disabled by applying an infinite pickup value with the setting  $\infty$  A.

2631 T  $I_{ph}$  STUB Time delay:

As the setting of 2630 above is infinity ( $\infty$ ), this setting is not relevant and left on the default value of 0.30 s.

2632  $3I_{0} >$  STUB Pickup:

This stage may be used as a normal definite time delay stage. In addition to this, it provides for blocking or release via binary input. For certain applications (e.g. 1 ½ CB) a STUB exists when the line isolator is open. By releasing this overcurrent stage via the mentioned binary inputs, a fast selective fault clearance for faults on the STUB can be obtained. In this application, no such STUB protection is required, so this stage is disabled by applying an infinite pickup value with the setting  $\infty$  A.

2633 T  $3I_{0}$  STUB Time delay:

As the setting of 2632 above is infinity ( $\infty$ ), this setting is not relevant and left on the default value of 2.00 s.

- 2634 Instantaneous trip via Teleprot./BI: The  $I >>$  stage is applied for this purpose, refer to setting 2614 in Chapter 15.2. Therefore set NO for this stage.
- 2635 Instantaneous trip after SwitchOnToFault: This function is not applied (refer to setting 2680 in Chapter 15.1). Therefore NO is set.

■ 16. Measurement supervision – Setting Group A

16.1 Balance / Summation

No.	Settings	Value
2901	Measurement Supervision	ON
2902A	Voltage Threshold for Balance Monitoring	50 V
2903A	Balance Factor for Voltage Monitor	0,75
2904A	Current Balance Monitor	0,50 A
2905A	Balance Factor for Current Monitor	0,50
2906A	Summated Current Monitoring Threshold	0,10 A
2907A	Summated Current Monitoring Factor	0,10
2908A	T Balance Factor for Voltage Monitor	5 sec
2909A	T Current Balance Monitor	5 sec

Fig. 46 Balance/Summation settings, measurement supervision

- 2901 Measurement Supervision: Only in exceptional cases will the measurement supervision not be activated. Therefore this setting should always be ON.

The advanced settings 2902A to 2909A can be used to modify the parameters of the monitoring functions. Generally, they can all be left on their default values.

16.2 Measured voltage failure

No.	Settings	Value
2910	Fuse Failure Monitor	ON
2911A	Minimum Voltage Threshold $U_{>}$	30 V
2912A	Maximum Current Threshold $I_{<}$	0,10 A
2913A	Maximum Voltage Threshold $U_{<}$ (3phase)	5 V
2914A	Delta Current Threshold (3phase)	0,10 A
2915	Voltage Failure Supervision	with current supervision
2916A	Delay Voltage Failure Supervision	3,00 sec

Fig. 47 Measured voltage fail settings, measurement supervision

- 2910 Fuse Failure Monitor: Only in exceptional cases will the fuse failure monitor not be activated. Therefore this setting should always be ON.

For the voltage failure detection, the default parameters can be applied for the advanced settings.

- 2915 Voltage Failure Supervision: In the event of energising the primary circuit with the voltage transformer secondary circuit out of service, an alarm “168 Fail  $U$  absent” will be issued and the emergency mode activated. This monitoring task can be controlled with this parameter 2915. As no auxiliary contacts of the circuit-breaker are allocated, it is only controlled with current supervision.

16.3 VT mcb

No.	Settings	Value
2921	VT mcb operating time	0 ms

Fig. 48 VT mcb settings, measurement supervision

- 2921 VT mcb operating time: If an auxiliary contact of the mcb is utilised (allocated in the matrix), the operating time of this contact must be entered here. Note that such an input is not required in practice as the relay detects all VT failures, including the operation of the mcb via measurement. This set time will delay all distance protection fault detection so it should in general not be used. In this application, it is also not required and therefore left on the default setting of 0 ms.

■ 17. Earth-fault overcurrent – Setting Group A

17.1 General

No.	Settings	Value
3101	Earth Fault overcurrent function is	ON
3102	Block E/F for Distance protection	with every Pickup
3174	Block E/F for Distance Protection Pickup	in zone Z1/Z1B
3103	Block E/F for 1pole Dead time	YES
3104A	Stabilisation Slope with Iphase	10 %
3105	3I0-Min threshold for Teleprot. schemes	0,46 A
3109	Single pole trip with earth fit prot.	NO
3170	2nd harmonic ratio for inrush restraint	15 %
3171	Max. Current, overriding inrush restraint	7,50 A
3172	Instantaneous mode after SwitchOnToFault	with Pickup and direction
3173	Trip time delay after SOTF	0,00 sec

Fig. 49 General settings, earth fault overcurrent

- 3101 Earth Fault overcurrent function is: For the clearance of high resistance earth faults this function provides better sensitivity than the distance protection. As high resistance earth faults are expected in this application, this function is activated by setting it ON.
- 3102 Block E/F for Distance protection: As the distance protection is more selective (defined zone reach) than the earth-fault protection and has superior phase selection it is set to block the E/F protection with every pickup.

- 3174 Block E/F for Distance Protection Pickup:  
As fast single-pole tripping is only done with Zone 1 and Zone 1B with the distance protection, the earth-fault protection is only blocked when the distance protection picks up in **Zone Z1/Z1B**.
- 3103 Block E/F for 1pole Dead time:  
During 1-pole dead times, load current can flow via the zero sequence path. To prevent incorrect operation of the earth-fault protection as a result of this it should be blocked. Therefore set **YES**.
- 3104A Stabilisation Slope with  $I_{\text{Phase}}$ :  
When large currents flow during faults without ground, CT errors (saturation) will cause current flow via the residual path. The earth-fault protection, having a very sensitive pickup threshold for high resistance faults, could pick up due to this CT error current. To prevent this, a stabilising characteristic is provided to increase the threshold when the phase currents are large. The characteristic is shown below in Figure 50. The default setting of **10 %** is suitable for most applications.

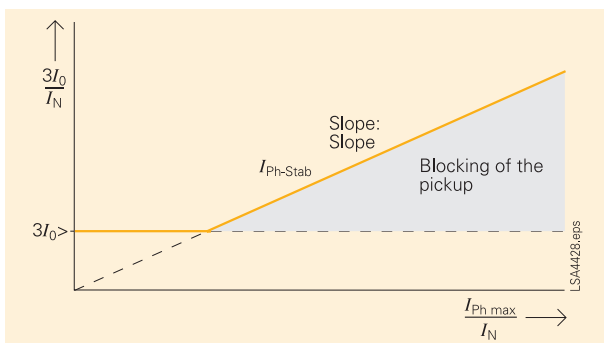

Fig. 50 Stabilisation of  $3I_0$  pickup threshold

- 3105  $3I_0$ -Min threshold for Teleprot. schemes:  
For directional comparison protection, in particular for the weak infeed echo function, a teleprotection send or echo block condition must be more sensitive than the teleprotection trip condition. This threshold determines the minimum earth current for teleprotection send and is set to 80 % of the most sensitive teleprotection trip stage. Set
- $$3I_{0\_TP} = 0.8 \cdot 3I_0 \gg$$
- $$3I_{0\_TP} = 0.8 \cdot 0.58$$
- $$3I_{0\_TP} = 0.46 \text{ A}$$
- Therefore apply the setting of **0.46 A**.
- 3109 Single pole trip with earth flt. prot.:  
The distance protection is set to cover all arc faults on the line. High resistance faults usually are due to mechanical defects (broken conductors or obstructions in the line) so that an automatic reclosure is not sensible. Therefore, set earth fault only for three-pole tripping by application of **NO**.
- 3170 2nd harmonic for inrush restraint:  
When energising the line, connected transformers and load may cause an inrush current with zero sequence component. This rush current can be identified by its 2nd harmonic content. In this application inrush blocking is not required and not applied in the individual stages. The setting is of no consequence, so leave the default value of **15 %**.
- 3171 Max. Current, overriding inrush restraint:  
If very large fault currents flow, CT errors may also cause some 2nd harmonic. Therefore the rush blocking is disabled when current is above this threshold. As stated for parameter 3170 above, the inrush restraint is not applied in this example. This setting is of no consequence, so leave the default value of **7.50 A**.
- 3172 Instantaneous mode after SwitchOnTo Fault:  
The earth-fault protection may be activated with a set time delay (parameter 3173) in the case of line energising (SOTF). In this application, only the distance protection function is used for SOTF so that this setting is of no consequence, so leave the default value of with **pickup and direction**.
- 3173 Trip time delay after SOTF:  
As stated for parameter 3172 above, this timer defines the delay of the SOTF trip by earth-fault protection. As it is not applied, the default value of **0.00 s** is left unchanged.

17.2  $3I_0>>>$ 

No.	Settings	Value
3110	Operating mode	Forward
3111	$3I_0>>>$ Pickup	3,50 A
3112	T $3I_0>>>$ Time delay	0,25 sec
3113	Instantaneous trip via Teleprot./BI	NO
3114	Instantaneous trip after SwitchOnToFault	NO
3115	Inrush Blocking	NO

Fig. 51  $3I_0>>>$  stage settings, earth fault overcurrent

- 3110 Operating mode:  
A total of 4 stages are available, one of which may be applied as inverse stage. In this application only three stages will be used, the  $3I_0>>>$  stage for fast (single time step) directional operation and the  $3I_0>>$  stage for time delayed directional operation and fast directional comparison as well as the  $3I_0>$  stage for non-directional backup operation. This stage must therefore be set to **Forward**.
- 3111  $3I_0>>>$  Pickup:  
This stage must operate with the same sensitivity as the backup (emergency) overcurrent stage  $3I_0>>$  (refer to setting 2612). Therefore apply the setting **3.50 A** here. Note that this stage is only active when distance protection is not picked up, and it is directional (no reverse fault operation) whereas the backup O/C stage only operates in the emergency mode when distance protection is not available.
- 3112 T  $3I_0>>>$  Time delay:  
This stage must operate with single time step delay. Therefore set **0.25 s** here.
- 3113 Instantaneous trip via Teleprot./BI:  
The stage  $3I_0>>>$  will operate with teleprotection, so the setting here is **NO**.
- 3114 Instantaneous trip after SwitchOnToFault:  
As stated above, only the distance protection operates with SOTF, so set **NO** here.
- 3115 Inrush Blocking:  
As stated above, inrush blocking is not applied, so set **NO** here.

17.3  $3I_0>>$ 

No.	Settings	Value
3120	Operating mode	Forward
3121	$3I_0>>$ Pickup	0,58 A
3122	T $3I_0>>$ Time Delay	0,50 sec
3123	Instantaneous trip via Teleprot./BI	YES
3124	Instantaneous trip after SwitchOnToFault	NO
3125	Inrush Blocking	NO

Fig. 52  $3I_0>>$  stage settings, earth fault overcurrent

- 3120 Operating mode:  
In this application only three stages will be used, the  $3I_0>>>$  stage for fast (single time step) directional operation and the  $3I_0>>$  stage for time delayed directional operation and fast directional comparison as well as the  $3I_0>$  stage for non-directional backup operation. This stage must therefore be set to **Forward**.
- 3121  $3I_0>>$  Pickup:  
This stage must operate for all internal high resistance faults, use a 20 % margin.  
$$3I_0 >> \text{Pickup} = 0.8 \cdot I_{1ph \min\_R}$$
$$3I_0 >> \text{Pickup} = 0.8 \cdot 729 = \underline{\underline{583 \text{ A}}}$$
  
In secondary values therefore set **0.58 A**.
- 3122 T  $3I_0>>$  Time delay:  
This stage must operate with two time step delays. Therefore set **0.50 s** here.
- 3123 Instantaneous trip via Teleprot./BI:  
The stage  $3I_0>>$  will operate with teleprotection, so the setting here is **YES**.
- 3124 Instantaneous trip after SwitchOnToFault:  
As stated above, only the distance protection operates with SOTF, so set **NO** here.
- 3125 Inrush Blocking:  
As stated above, inrush blocking is not applied, so set **NO** here.



17.4  $3I_0>$ 

No.	Settings	Value
3130	Operating mode	Non-Directional
3131	3I0> Pickup	0,58 A
3132	T 3I0> Time Delay	1,00 sec
3133	Instantaneous trip via Teleprot./BI	NO
3134	Instantaneous trip after SwitchOnToFault	NO
3135	Inrush Blocking	NO

Fig. 53  $3I_0>$  stage settings, earth fault overcurrent

## 3130 Operating mode:

In this application only three stages will be used, the  $3I_0>>>$  stage for fast (single time step) directional operation and the  $3I_0>>$  stage for time delayed directional operation and fast directional comparison as well as the  $3I_0>$  stage for non-directional backup operation. This stage must therefore be set to **Non-Directional**.

3131  $3I_0>$  Pickup:

This stage must operate for all internal high resistance faults, the same as  $3I_0>>>$ , but non-directional and with longer time delay. In secondary values therefore set **0.58 A**.

3132 T  $3I_0>$  Time delay:

This stage must operate with four time step delays. Therefore set **1.00 s** here.

## 3133 Instantaneous trip via Teleprot./BI:

The stage  $3I_0>>>$  will operate with teleprotection, so the setting here is **NO**.

## 3134 Instantaneous trip after SwitchOnToFault:

As stated above, only the distance protection operates with SOTF, so set **NO** here.

## 3135 Inrush Blocking:

As stated above, inrush blocking is not applied, so set **NO** here.

17.5  $3I_0$  Inverse time

No.	Settings	Value
3140	Operating mode	Inactive
3141	3I0p Pickup	1,00 A
3143	3I0p Time Dial	0,50 sec
3147	Additional Time Delay	1,20 sec
3148	Instantaneous trip via Teleprot./BI	NO
3149	Instantaneous trip after SwitchOnToFault	NO
3150	Inrush Blocking	NO
3151	IEC Curve	Normal Inverse

Fig. 54  $3I_0$  Inverse time stage settings, earth fault overcurrent

## 3140 Operating mode:

This stage is not required so it is set to **Inactive**.

Because this stage is inactive, the settings 3141 to 3151 are of no consequence and left on their default values.

## 17.6 Direction

No.	Settings	Value
3160	Polarization	with U0 + IY or U2
3162A	ALPHA, lower angle for forward direction	338°
3163A	BETA, upper angle for forward direction	122°
3164	Min. zero seq. voltage 3U0 for polarizing	3,8 V
3166	Min. neg. seq. polarizing voltage 3U2	3,8 V
3167	Min. neg. seq. polarizing current 3I2	0,58 A
3168	Compensation angle PHI comp. for Sr	255°
3169	Forward direction power threshold	0,3 VA

Fig. 55 Direction settings, earth fault overcurrent

## 3160 Polarization:

Because both applied stages of the earth-fault overcurrent protection are directional (forward), the choice of polarising signal must be carefully considered. If both negative and zero sequence infeed are present at the relay location polarisation with **U0 + IY or U2** provides excellent results. The earth current from a star connected and earthed transformer winding is only included, when the 4th current input of the relay is connected as such. In this application, this current input measures the residual current of the protected line, (parameter 220 in Chapter 7.1). Therefore only the zero sequence or negative sequence voltage are used as polarising signal with this setting. The choice is automatic (the larger of the two values is chosen individually during each fault).



3162A ALPHA, lower angle for forward direction:  
The default direction limits have been optimised for high resistance faults and are left unchanged at 338° here.

3163A BETA, upper angle for forward direction:  
The default direction limits have been optimised for high resistance faults and are left unchanged at 122° here.

3164 Min. zero seq. voltage  $3U_0$  for polarizing:  
The zero sequence voltage is one of the values for directional polarising. Under high resistance fault conditions, this value may become very small. For the setting it is calculated using the minimum single-phase fault current under high resistance fault conditions and the smallest zero sequence source impedance (this includes a safety margin as these two conditions will not coincide):

$$3I_{0\min} = I_{1\text{ph min}_R} \cdot Z_{0\text{source}_\min}$$

$$3I_{0\min} = 729 \cdot 20 = 14.58 \text{ kV}$$

As secondary value this is:

$$3U_{0\min\_sec} = 3U_{0\min} \cdot \frac{100 \text{ V}}{380 \text{ kV}}$$

$$3U_{0\min\_sec} = 14.58 \text{ kV} \cdot \frac{100 \text{ V}}{380 \text{ kV}} = 3.8 \text{ V}$$

Therefore apply the setting 3.8 V.

3166 Min. neg. seq. polarizing voltage  $3U_2$ :  
Although a similar calculation as done for 3164 would return a smaller value (50 %), this is not applied, as an automatic selection of the larger of the two voltages was set (parameter 3160). The setting applied here therefore is the same as that for the zero sequence voltage. Therefore apply the setting 3.8 V.

3167 Min. neg. seq. polarizing current  $3I_2$ :  
Apply here the minimum negative sequence current flowing for high resistance faults with a 20 % margin.

$$3I_{2\min} = 0.8 \cdot I_{1\text{ph min}_R}$$

$$3I_{2\min} = 0.8 \cdot 729 = 583.2 \text{ A}$$

Therefore apply the setting 0.58 A.

3168 Compensation angle PHI comp. for  $S_F$ :  
This setting is only relevant for direction decisions based on zero sequence power. In this application it is of no consequence and left on default value of 255°.

3169 Forward direction power threshold:  
This setting is only relevant for direction decisions based on zero sequence power. In this application it is of no consequence and left on default value of 0.3 VA.

### 18. Teleprotection for earth fault overcurrent – Setting Group A

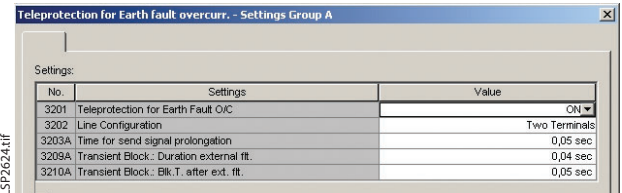

Fig. 56 Teleprotection for earth fault overcurrent settings

3201 Teleprotection for Earth Fault O/C:  
In this application the teleprotection is required and applied as “Directional Comparison Pickup”, refer to parameter 132 in Chapter 4. This function is therefore activated by setting it ON.

3202 Line Configuration:  
The line is a **two terminal line**.

3203A Time for send signal prolongation:  
As the same type of communication with the same channel delay time is used for distance teleprotection and earth-fault teleprotection, the same setting consideration as for parameter 2103A in Chapter 13 applies here. Therefore in this example a setting of 0.05 s is applied.

3209A Transient Block.: Duration external flt.:  
As the same type of communication with the same channel delay time is used for distance teleprotection and earth-fault teleprotection, the same setting consideration as for parameter 2109A in Chapter 13 applies here. Therefore in this example a setting of 0.04 s is applied.

3210A Transient Block.: Blk. T. after ext. flt.:  
As the same type of communication with the same channel delay time is used for distance teleprotection and earth-fault teleprotection, the same setting consideration as for parameter 2110A in Chapter 13 applies here. Therefore in this example a setting of 0.05 s is applied.

## ■ 19. Automatic reclosure – Setting Group A

### 19.1 General

No.	Settings	Value
3401	Auto-Reclose function	ON
3402	CB ready interrogation at 1st trip	NO
3403	Reclaim time after successful AR cycle	3,00 sec
3404	AR blocking duration after manual close	1,00 sec
3406	Evolving fault recognition	with Trip
3407	Evolving fault (during the dead time)	starts 3pole AR-cycle
3408	AR start-signal monitoring time	0,20 sec
3409	Circuit Breaker (CB) Supervision Time	3,00 sec
3410	Send delay for remote close command	∞ sec
3411A	Maximum dead time extension	10,00 sec

Fig. 57 General settings, automatic reclosure

#### 3401 Auto-Reclose function:

In this application the automatic reclosure function is required and applied with “1 Cycle” and “with Trip and Action Time”, refer to parameters 133 and 134 in Chapter 4. This function is therefore activated by setting it ON.

#### 3402 CB ready interrogation at 1st trip:

Before a reclosure is attempted the circuit-breaker status must be checked. This can be done before the reclose cycle is started (prior/at time of initiation) or before the reclose command is issued. In this application the breaker status is checked before the close command is issued by the recloser, so this setting must be NO.

#### 3403 Reclaim time after successful AR cycle:

If the reclose is successful, the recloser must return to the normal state which existed prior to the first fault. The time set here is started by each reclose command and must take the system conditions into account (also the circuit-breaker recovery time may be considered). Here a setting of 3.00 s is applied.

#### 3404 AR blocking duration after manual close:

If the manual close binary input is assigned, then the AR should be blocked for a set time after manual close to prevent AR when switching onto a fault. In this application the manual close binary input is not assigned, SOTF is recognised by current flow and AR is not initiated in this case. This setting is not relevant here as the manual close binary input is not assigned, the default setting of 1.00 s is left unchanged.

#### 3406 Evolving fault recognition:

If during the single-pole dead time a further fault is detected (evolving fault), the AR function can respond to this in a defined manner. The detection of evolving fault in this application will be done by detection of a further (new) trip command initiation to the AR function. Therefore set with Trip.

#### 3407 Evolving fault (during the dead time):

The response to the evolving fault during the single-pole dead time is set here. In this application it is set to starts 3pole AR-cycle.

#### 3408 AR start-signal monitoring time:

If the AR start signal (protection trip) does not reset after a reasonable time (breaker operating time plus protection reset time), then a problem with either the circuit-breaker (breaker failure) or the protection exists and the reclose cycle must not be started. Here the maximum time for the initiate signal is set. If it takes longer, the AR cycle is not started and a final trip condition is set. Apply a setting of twice the breaker operating time plus protection reset time, i.e. 0.20 s.

#### 3409 Circuit Breaker (CB) Supervision Time:

As the CB ready status will be checked prior to issue of the close command, a time limit must be applied during which this ready status must be reached. If it takes longer, a final trip status is set and reclosure does not take place. This time limit is set here to be 3.00 s.

#### 3410 Send delay for remote close command:

The AR function can be applied to send a close command to the remote end via communication channels. This is not applied here, so the time is left on the default setting of infinity, ∞ s.

#### 3411A Maximum dead time extension:

The AR function can be applied to wait for release by sync. check or CB status before release of close command. Here, the maximum extension of the dead time in the course of waiting for release conditions is set. In practice, a limitation to less than 1 minute is practical. In this application 10 s will be used.

19.2 1<sup>st</sup> auto reclose cycle

No.	Settings	Value
3450	Start of AR allowed in this cycle	YES
3451	Action time	0,20 sec
3456	Dead time after 1 pole trip	1,00 sec
3457	Dead time after 3pole trip	0,50 sec
3458	Dead time after evolving fault	0,50 sec
3459	CB ready interrogation before reclosing	YES
3460	Request for synchro-check after 3pole AR	YES

Fig. 58 1<sup>st</sup> AR cycle settings, automatic reclosure

- 3450 Start of AR allowed in this cycle:  
As this is the only AR cycle that is applied, starting must be allowed in this cycle, so set this parameter to YES.
- 3451 Action time:  
As indicated with parameter 134 in Chapter 4, the action time is used to differentiate between faults cleared without delay by the main protection and backup protection operation for external faults. The action time must be set below the calculated coordination time step (0.25 s) and must be longer than the slowest operation with teleprotection (60 ms). A time of 0.20 s is applied.
- 3456 Dead time after 1 pole trip:  
The dead time must allow for the arc gases to dissipate. During single-pole trip this time is longer, because the arc is still supplied by capacitive coupled current from the healthy phases after the circuit-breaker is open single pole. In practice a time of 1.00 s has proven to provide good results.
- 3457 Dead time after 3 pole trip:  
The dead time must allow for the arc gases to dissipate. During three-pole trip this time is short. In practice a time of 0.50 s has proven to provide good results.
- 3458 Dead time after evolving fault:  
As set in parameters 3407 and 3408 above, a three-pole dead time will be started in the case of evolving fault. Here the same time as in parameter 3457 can be used because this time is started with the three-pole trip issued due to the fault evolving from single to three phase. Therefore set 0.50 s.
- 3459 CB ready interrogation before reclosing:  
As stated above, the CB status will be checked before issue of close command. Therefore set YES.
- 3460 Request for synchro-check after 3pole AR:  
The sync. check condition must be checked before issue of close command. Therefore set YES.

## 19.3 3pTRIP / dead line charge / reduced dead time

No.	Settings	Value
3430	3pole TRIP by AR	NO
3431	Dead Line Check or Reduced Dead Time	Without
3436	Supervision time for dead/ live voltage	0,10 sec
3440	Voltage threshold for live line or bus	48 V
3441	Voltage threshold for dead line or bus	30 V

Fig. 59 3-pole Trip/DLC/RDT settings, automatic reclosure

- 3430 3pole TRIP by AR:  
If the AR function is initiated by single-pole trip signals, it may in the course of a single-pole AR cycle detect that the conditions for single-pole reclosure are no longer valid (e.g. because of further single-pole trip during the dead time or auxiliary contact status from the breaker indicating multiple pole open, etc.). In such an event, the AR function may issue a three-pole trip before proceeding with a three-pole AR cycle or setting the final trip condition. This setting determines whether the AR function will issue such a three-pole trip. In this application no external initiate signals are applied so this setting is set to NO, because the internal protection functions can manage their own three-pole coupling of the trip signal when required.
- 3431 Dead Line Check or Reduced Dead Time:  
Special reclose programs can be applied to prevent repetitive reclose onto fault and to minimise dead times. In this application these programs are not used, so set Without.

The settings 3438, 3440 and 3441 are of no consequence, because 3431 is set to "Without".  
Leave these settings on their default values.

## 19.4 Start autoreclose

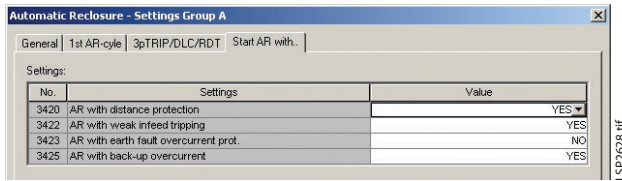

Fig. 60 Settings for starting the AR, Automatic reclosure

- 3420 AR with distance protection:  
The distance protection will trip single pole and three pole and start the autoreclosure, so set YES here.
- 3422 AR with weak infeed tripping:  
The weak infeed tripping will trip single pole and three pole and start the autoreclosure, so set YES here.
- 3423 AR with earth fault overcurrent prot.:  
The earth-fault overcurrent protection will trip three pole and not start the autoreclosure, so set NO here.
- 3425 AR with back-up overcurrent:  
The backup overcurrent protection will trip and start the autoreclosure, so set YES here. Note that due to the action time (parameter 3451 in Chapter 19.2) only the accelerated trip with teleprotection will result in reclosure.

## 20. Synchronism and voltage check – Setting Group A

### 20.1. General

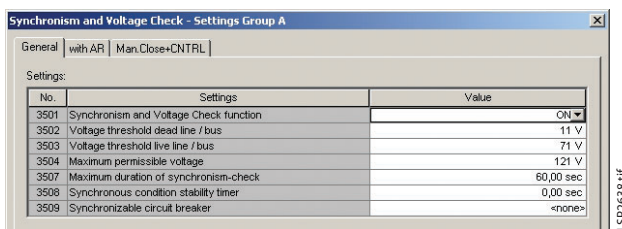

Fig. 61 General settings for synchronism and voltage check

- 3501 Synchronism and Voltage Check function:  
In this application the synchro check is used, so this function must be selected ON.
- 3502 Voltage threshold dead line/bus:  
If the measured line/bus voltage is below this set threshold, the line/bus is considered to be switched off (dead). In this application the L3-L1 phase to phase voltage is used for synchronism check, so that the voltage thresholds must be based on phase to phase voltage. In general, a setting of 10 % can be applied, when the voltage is below 10 %, the line/bus is definitely dead.

Where parallel lines can couple in larger voltages onto the dead line, a higher setting may be appropriate. In this case, no parallel lines exist, so the setting of 10 % will be used:

$$U_{\text{dead}} = 0.1 \cdot U_N$$

$$U_{\text{dead}} = 0.1 \cdot 110 = 11 \text{ V}$$

The value for  $U_N$  in this case (110 V) is based on the busbar voltage transformers (phase to phase), as this results in the larger (more conservative) setting. Apply the setting of 11 V.

- 3503 Voltage threshold live line/bus:  
If the measured line/bus voltage is above this set threshold, the line/bus is considered to be switched on (live). In this application the L3-L1 phase to phase voltage is used for synchronism check, so that the voltage thresholds must be based on phase to phase voltage. The setting must be below (20 % safety clearance) the minimum anticipated operating voltage (in this example 85 % of the nominal voltage):

$$U_{\text{live}} = 0.8 \cdot 0.85 \cdot U_N$$

$$U_{\text{live}} = 0.8 \cdot 0.85 \cdot \frac{400 \text{ kV}}{380 \text{ kV}} \cdot 100 = 71.6 \text{ V}$$

The value for  $U_N$  in this case ( $400/380 \cdot 110 \text{ V}$ ) is based on the line voltage transformers (phase to phase), as this results in the lower (more conservative) setting. Apply the setting of 71 V.

- 3504 Maximum permissible voltage:  
If the measured line or bus voltage is above this setting, it is considered to be a too large operating voltage for release of a close command. This setting must be above the highest expected operating voltage that is still acceptable for release of the close command. In general, a setting of 110 % of the normal operating voltage is recommended. On long lines, the local line voltage fed from the remote end may rise to a higher value due to the Ferranti effect (normally compensated by shunt reactors on the line). In this case, a higher setting may be required. In this example we will use a 110 % setting:

$$U_{\text{max}} = 1.10 \cdot U_N$$

$$U_{\text{max}} = 1.10 \cdot 110 = 121 \text{ V}$$

The value for  $U_N$  in this case (110 V) is based on the busbar voltage transformers (phase to phase), as this results in the larger (more conservative) setting. Apply the setting of 121 V.

- 3507 Maximum duration of synchronism check:  
If the synchronism check conditions are not obtained within this set time, the sync. check is terminated without release or close. The person that issues the sync. check request (operator close command initiation) expects a response from the switchgear within a reasonable time. This time should be set to the maximum time such operating personnel would accept to wait for a response. Typically, a setting of **60.00 s** is an acceptable delay.
- 3508 Synchronous condition stability timer:  
When the set synchro check conditions are met, the release can be delayed by this setting to ensure that this condition is not only a transient condition. In general, this additional stability check is not required, so that this setting can be set to **0.00 s**.
- 3509 Synchronizable circuit breaker:  
The integrated control functions may also trigger the sync. check measurement. For this purpose the appropriate switchgear item can be selected in this setting. In this application example, the integrated control functions are not used, so that the setting **<none>** is applied.

- 3510 Operating mode with AR:  
If the close release must be possible under asynchronous conditions (line and bus frequency are not the same), then the circuit-breaker closing time must be considered for timing of the close command. Refer to setting 239 in Chapter 7.3. In this example closing under asynchronous conditions must be possible, so apply the setting: **with consideration of CB closing time**.
- 3511 Maximum voltage difference:  
In this setting the maximum voltage magnitude difference is set. If the magnitudes of the line and bus voltage differ by more than this setting, the sync. check function will not release reclosure. As sync. check is done with phase to phase voltage in this case, the setting must be based on ph-ph voltage. Use the difference between the maximum and minimum operating voltage to obtain the worst case result:

$$U_{Diff\ max} = (U_{N\ max} - U_{N\ min})$$

$$U_{Diff\ max} = \left( 121 - \frac{400\ kV}{380\ kV} \cdot 100 \cdot 0.85 \right)$$

$$U_{Diff\ max} = 31.5\ V$$

A setting of 31.5 V is under normal circumstances too large, as switching with such a large delta would cause a severe transient in the system. Unless special circumstances exist, such as very long lines with Ferranti voltage rise or very weak interconnections without voltage compensation (e.g. tap changers), an upper limit of approximately 20 % of the nominal voltage should be applied:

$$U_{Diff\ max} = 0.2 \cdot U_N$$

$$U_{Diff\ max} = 0.2 \cdot 110 = 22\ V$$

Therefore, apply a setting of 22 V.

- 3512 Maximum frequency difference:  
If the frequency difference between line and bus voltage is less than this setting, the sync. check conditions for async. switching can be used. The sync. conditions for switching apply, if the frequency difference is less than 0.01 Hz. Switching with large frequency difference will cause severe transients to the system. In common practice, an upper limit of **0.10 Hz** is suitable.

**20.2. Settings for operation with auto-reclosure**

The following group of settings is relevant for close commands that originate from the auto-reclose function. This can be the internal AR, which is directly coupled with the internal sync. check, or an external AR device that couples the trigger signal via binary input to the sync. check function.

No.	Settings	Value
3510	Operating mode with AR	with consideration of CB closing time
3511	Maximum voltage difference	22,0 V
3512	Maximum frequency difference	0,10 Hz
3513	Maximum angle difference	40 °
3515A	Live bus / live line and Sync before AR	YES
3516	Live bus / dead line check before AR	YES
3517	Dead bus / live line check before AR	NO
3518	Dead bus / dead line check before AR	NO
3519	Override of any check before AR	NO

Fig. 62 Sync. check settings for auto-reclose trigger



- 3513 Maximum angle difference:  
Under synchronous switching conditions ( $f_{diff} < 0.01$  Hz) the angle difference between the bus and line voltage is also checked. This angle under synchronous conditions is stable and mainly due to the transmission angle of the system. In this example, a maximum angle of  $40^\circ$  will be applied.
- 3515A Live bus / live line and Sync before AR:  
In this application, the auto-reclose function may initiate closing when bus and line voltage are live; therefore set YES. The above sync. check conditions will then be monitored before closing is released.
- 3516 Live bus / dead line check before AR:  
In this application, the auto-reclose function may initiate closing to energise a dead line; therefore set YES.
- 3517 Dead bus / live line check before AR:  
In this application, the auto-reclose function may not initiate closing to energise a dead bus; therefore set NO.
- 3518 Dead bus / dead line check before AR:  
In this application, the auto-reclose function may not initiate closing to connect a dead bus to a dead line; therefore set NO.
- 3519 Override of any check before AR:  
The sync. check override is only used during testing or commissioning. Therefore set NO.
- 3530 Operating mode with Man.Cl:  
If the close release must be possible under asynchronous conditions (line and bus frequency are not the same), then the circuit-breaker closing time must be considered for timing of the close command. Refer to setting 239 in Chapter 7.3. In this example closing under asynchronous conditions must be possible, so apply the setting: **with consideration of CB closing time.**
- 3531 Maximum voltage difference:  
The same consideration as for the AR closing in parameter 3511 applies. Therefore, apply a setting of 22 V.
- 3532 Maximum frequency difference:  
The same consideration as for the AR closing in parameter 3512 applies. Therefore, apply a setting of 0.10 Hz.
- 3533 Maximum angle difference:  
The same consideration as for the AR closing in parameter 3513 applies. Therefore, apply a setting of  $40^\circ$ .
- 3535A Live bus / live line and Sync before MC:  
In this application, the manual close may initiate closing when bus and line voltage are live; therefore set YES. The above sync. check conditions will then be monitored before closing is released.
- 3536 Live bus / dead line check before Man.Cl.:  
It is common practice to allow all closing modes for manual close, so apply the setting YES.
- 3537 Dead bus / live line check before Man.Cl.:  
Refer to setting 3536; therefore set YES.
- 3538 Dead bus / dead line check before Man.Cl.:  
Refer to setting 3536; therefore set YES.
- 3539 Override of any check before Man.Cl.:  
The sync. check override is only used during testing or commissioning. Therefore set NO.

### 20.3 Settings for operation with manual close and control

The following group of settings is relevant for close commands that originate from the manual close binary input or internal control function.

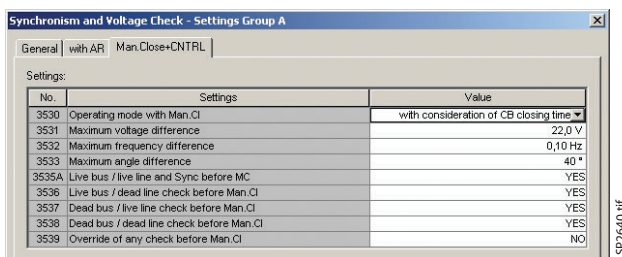

No.	Settings	Value
3530	Operating mode with Man.Cl	with consideration of CB closing time
3531	Maximum voltage difference	22.0 V
3532	Maximum frequency difference	0.10 Hz
3533	Maximum angle difference	40 °
3535A	Live bus / live line and Sync before MC	YES
3536	Live bus / dead line check before Man.Cl	YES
3537	Dead bus / live line check before Man.Cl	YES
3538	Dead bus / dead line check before Man.Cl	YES
3539	Override of any check before Man.Cl	NO

Fig. 63 Sync. check settings for manual close and control input trigger



■ 21. Fault locator – Setting Group A

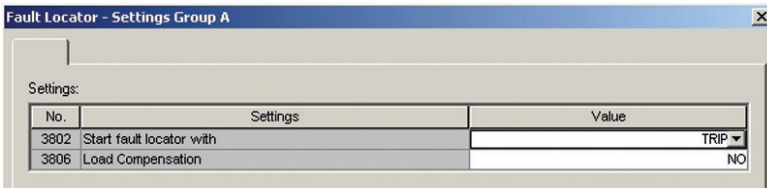

Fig. 64 Fault locator settings

- 3802 Start fault locator with:  
The fault locator can only provide meaningful data for faults on the protected line unless the downstream feeders are in a pure radial configuration without intermediate infeed. In this application, there is infeed at the remote bus, so that the fault locator data is only desired when the protection trips for internal faults. Therefore apply the setting with TRIP.
- 3806 Load Compensation:  
The result of the single ended fault location computation may be inaccurate due to the influence of load angle and fault resistance. This was described in conjunction with the parameter 1307 in Chapter 11.1. For single phase to ground faults and for phase to phase faults without ground a load compensated measurement can be applied to achieve better results. This function does not work under all conditions, and a fault location output that closely resembles the protection operation is desired in this application, so the load compensation is switched off by setting NO here.

■ 22. Oscillographic fault records

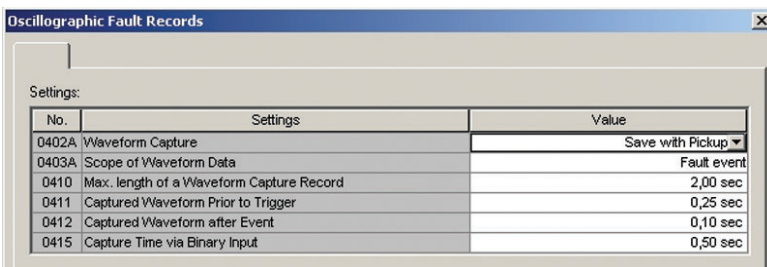

Fig. 65 Settings for the oscillographic fault recording

- 0402A Waveform Capture:  
In this application a recording must be saved during internal and external faults, even if the relay does not trip. Therefore apply the setting **Save with Pickup** to save the recording every time the relay detects a fault (picks up).  
With settings 0403A to 0415, the length and configuration of the oscillographic record can be set to match the user requirements.

■ 23. General device settings

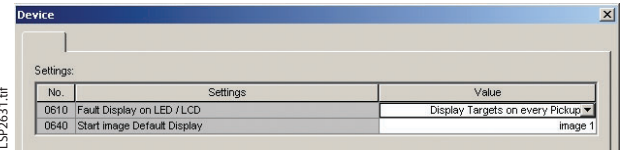

Fig. 66 General device settings

- 0610 Fault Display on LED / LCD:  
The LED and LCD image/text can be updated following pickup or latched with trip. In this application the last pickup will be indicated: **Display Targets on every Pickup**.
- 0640 Start image Default Display:  
The LCD display during default conditions (no fault detection or trip) can be selected from a number of standard variants. Here, variant 1 is selected with the setting image 1.

■ 24. Time synchronization & time format settings

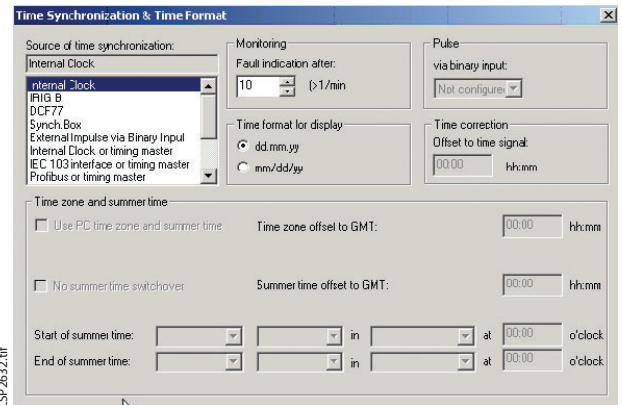

Fig. 67 Time synchronization and time format settings

Time synchronization settings can be applied here. Various sources for synchronizing the internal clock exist as shown in Figure 67.

25. Interface settings

25.1 Serial port on PC settings

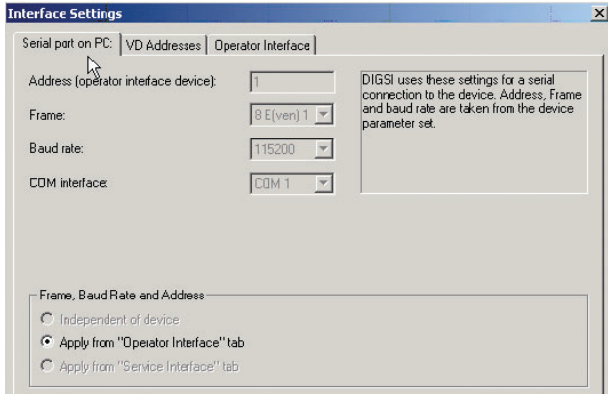

Fig. 68 Settings for serial port on PC

The PC serial port configuration is shown here. No settings are required in this case.

25.2 VD address settings

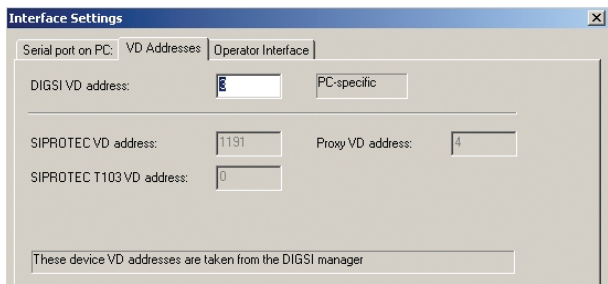

Fig. 69 Settings for VD address

These addresses can be left on default values.

25.3 Operator interface settings

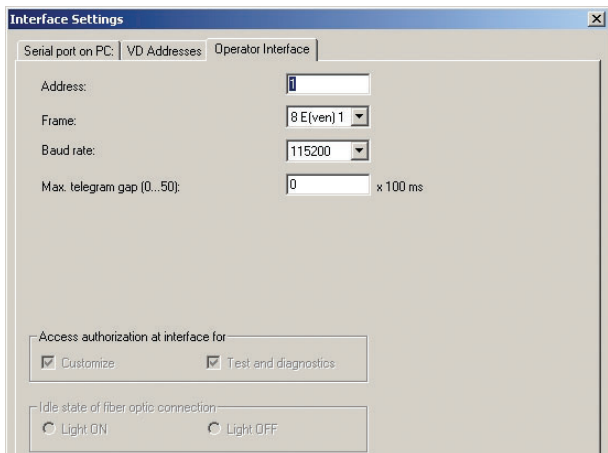

Fig. 70 Settings for operator interface

The settings here apply to the system interface, if this is used.

26. Password settings

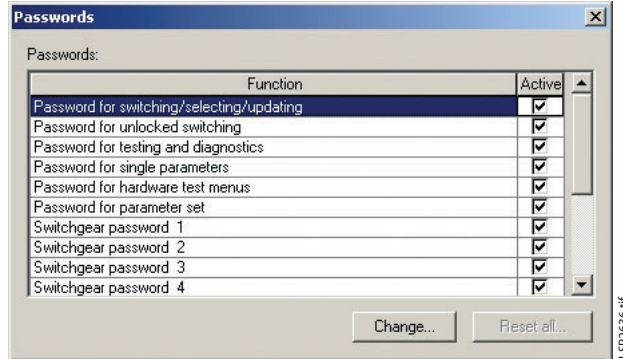

Fig. 71 Settings for password access

Various password access levels can be applied as shown in Figure 71.

27. Language settings

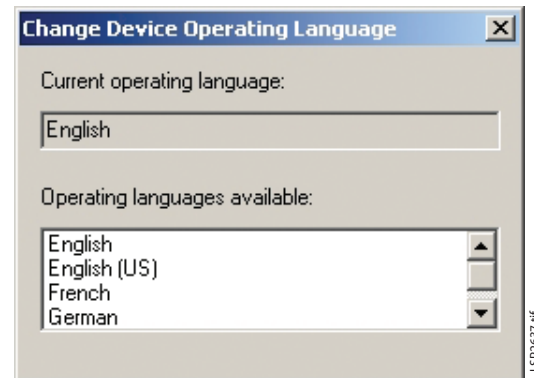

Fig. 72 Settings for language in the device

The language settings shown depend on the languages that are installed with the DIGSI device driver on the PC.

■ 28. Summary

SIPROTEC 7SA6 protection relays comprise the functions required for overall protection of a line feeder and can thus be used universally. The diversity of parameterization options enables the relay to be adapted easily and clearly to the respective application using the DIGSI 4 operating program.

Many of the default settings can easily be accepted and thus facilitate the work for parameterization and setting. Already when ordering, economic solutions for all voltage levels can be realized by selection of the scope of functions.