



## Communications solutions in power networks – around the world.

Reference examples

Power Transmission and Distribution

**SIEMENS**



# Connecting the world. With the expertise of a life-cycle partner for your power network.

## Communication as a key success factor for power utilities ...

Communications solutions connect the world. In power utility operation they have likewise become one of the key factors for success. Once restricted to dealing with internal issues, communication systems are now playing an important role in business relations with suppliers and customers. Clearly, the highest return on investment will be delivered by a network that achieves the highest level of efficiency in all subareas.

## ... driven by innovative solutions from Siemens ...

With Siemens' vast experience in integrating all relevant technologies, utility operators can build on reliable, innovative and future-proof solutions. Around the globe there are many examples not only of highly competitive solutions but also of sound, long-lasting partnerships. It begins with analyzing your requirements and continues with professional services aimed at more efficient, accessible and profitable power operation.

## ... backed by faithful partnership with our customers around the globe.

This brochure gives you a picture of how various power utilities benefit from our combined expertise in both power supply and telecommunications. You can count on us to smoothly integrate new technologies and legacy systems into one attractive, complete solution without interface issues. You get support when needed, quickly and far beyond our contractual obligations. And last but not least, you can build on our financial commitment to your project. We're here to connect the world.

## Communications solutions for power utilities. With Siemens, this means...

- ... sharing more than 160 years of innovation
- ... staying at the leading edge, thanks to R&D investments of 5.2 billion euros (2005)
- ... close at hand, in more than 190 countries around the world
- ... little or no need for coordination on your part
- ... responsibility lies with Siemens

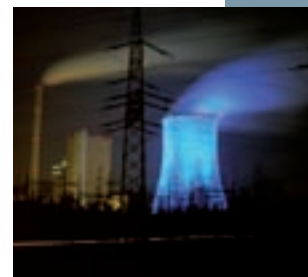



See how it works in practice – a selection of our projects.

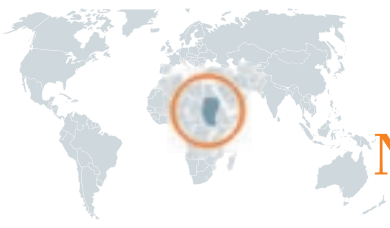

# New load dispatch center SCADA/EMS and telecommunication equipment

Success story National Electricity Corporation, Khartoum, Sudan

## The challenge:

At present the NEC operates several thermal and hydropower generating stations and approximately 1,400 km of transmission lines. To gear up for the future, a state-of-the-art load dispatch center (LDC) needed to be established. The main project goal was to support grid control with software for higher efficiency of generation, transmission and distribution. Additionally, extension of the existing communication systems for telephony, teleprotection signaling and data/alarm transmission was necessary.

## Our solution:

Siemens provided the NEC with an optical transmission system based on STM-4 add/drop multiplexers to provide a reliable and economical method of transporting SDH traffic. Approximately 20 substations and seven power stations were linked with the new load dispatch center at the Kilo X site in Khartoum. Later, the final network will be extended to around 50 network nodes.

Transmission of data and voice was achieved by one link using Power Line Carriers (PLC) over high-voltage transmission lines aided by line trap and coupling capacitors. Transmission of signals via the SDH networks runs on Optical Ground Wire (OPGW), which was installed under live-line conditions for a length of 240 km. The project was faced with the special challenge of implementing communication links over extremely high distances without a repeater. By using optical waveshifters and amplifiers, Siemens was once again able to provide the perfect solution.



## Benefits

- One source solution – complete portfolio
- Turnkey system including design and engineering
- Network security
- Stability of supply
- Efficiency of generation, transmission and distribution
- Load dispatch with scheduling
- Economic energy and plant management
- Complete and trouble-free turnkey solution

## Scope of supply

- SCADA/Energy management system
- Optical transmission system based on STM-4 add/drop multiplexers
- PDH/SDH backbone platform for SDH traffic transport
- Digital PLC link
- Remote Terminal Units (RTUs) in substations – Ethernet-based
- Live-line installation of OPGW
- Protection Data Management System (PDMS)
- Private Automatic Exchanges (PAXs)
- Telecommunication included design, manufacture, testing, delivery and commissioning

Increasing and stabilizing energy systems and working toward meeting requirements for industrial growth is a top priority for Sudan's power network. This is why the National Electricity Corporation (NEC) asked Siemens to develop their "new load dispatch center SCADA/EMS and telecommunication equipment" (SCADA/EMS and Telecom) in Khartoum. Siemens provided a turnkey telecommunication solution, which allows for expansion and modernization.



Increasing electricity and heat demands in Mongolia have created the need for cost-effective and sustainable access to energy. To this end, the National Dispatching Center (NDC) of Mongolia commissioned Siemens to build a new load dispatch center (LDC) for the Central Energy System (CES). With the new center the NDC is able to fulfill requirements for up-to-date network supervision and future expansion.

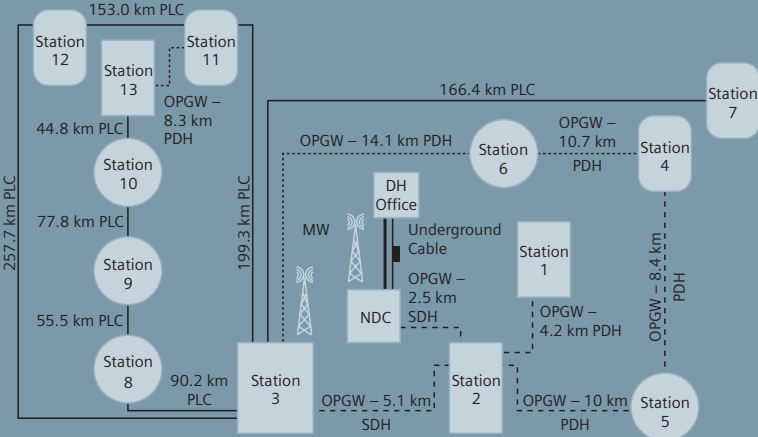
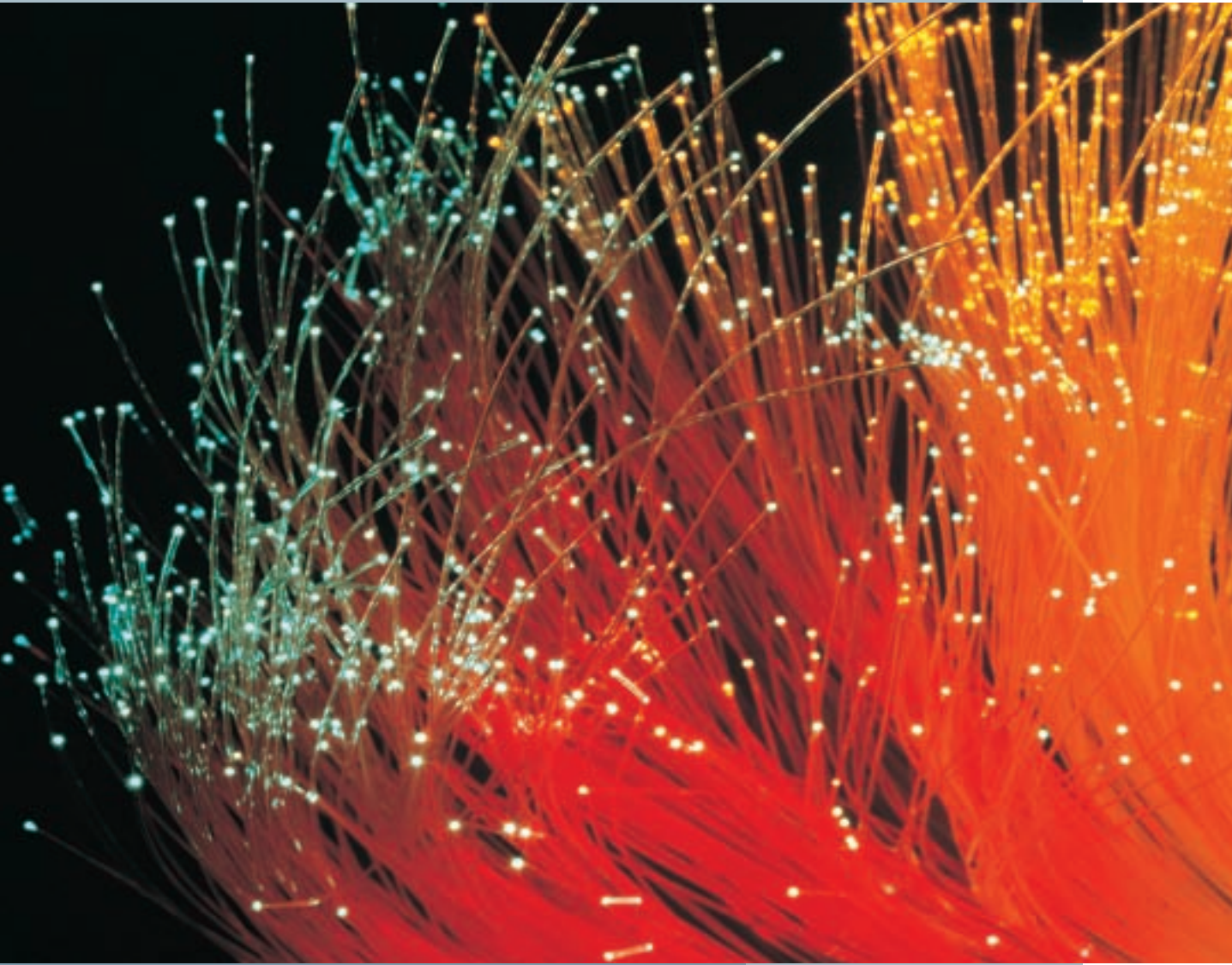

# Optimized central energy system HV grid

Success story National Dispatching Center (NDC), Mongolia



## The challenge:

Dependable communication is indispensable to the operation of electrical networks. However, the average age of the communication equipment of the NDC was 20 years or older. For speech communication between the NDC and the substations only VHF radio communication and/or public telephones had been used and did not meet requirements. The PLC communication network had deteriorated and was no longer dependable.

An overhaul of the telecommunication and telephone system between the HV substations and power stations as well as the dispatching centers at the NDC and the transmission company was of utmost importance.

## Our solution:

The core of the new load dispatch center is a fully redundant, state-of-the-art SCADA system for control and monitoring of the high-voltage network and equipment in the 13 outstations. For data and voice messages a communication network was established using transmission over fiber-optic cables (OPGW and underground cable), SDH and Power Line Carrier (PLC) equipment as well as microwave radio data transmission equipment. Already existing line traps and coupling capacitors were reused for the newly installed digital PLC telecommunication links. The customized Siemens solution was designed for maximum stability and optimization of the central energy system HV grid.

## Benefits

- Reliable telecommunication system
- More efficient management of all generation facilities
- Stabilized energy access
- Fewer and shorter interruptions
- Reduction in transmission network losses
- Complete turnkey solution for the NDC



## Scope of supply

- SCADA system including Remote Terminal Units (RTUs)
- Redundant telecommunication network for data and voice communication
- Complete system integration including engineering, installation, delivery, commissioning and testing
- Line traps and coupling capacitors
- Digital Power Line Carrier (dPLC) for voice and data transmission
- SDH/STM-1 fiber-optic links
- Private Automatic Branch Exchanges (PABX) at several stations
- Optical ground wire OPGW
- Underground fiber-optic cables
- Optical terminal equipment
- Microwave link
- Telephone system
- On-site training sessions



# Siemens: supporting growth in Mexico over 100 years

## Success story CFE and LyF, El Cajón, Mexico

### The challenge:

Mexico's overall growth in demand for electricity is expected to range between 5.6 percent and 6.1 percent annually. To meet this need in the future, restrictions have been relaxed to allow private and foreign investment to flow into the energy sector. Additionally, NAFTA has strengthened Mexico's economic importance as a link between North and South America. Both factors indicate an impending surge in Mexico's energy projects.

To help them keep up with their requirements, Siemens will continue to work closely with Mexico's two power supply companies, the Federal Power Commission (CFE) and Luz y Fuerza del Centro (LyF). Together both companies serve Mexico's 100 million inhabitants with electric energy generated through hydro, thermal, wind-driven, and nuclear power plants.

### Our solution:

Siemens was asked to work on the El Cajón project not only because it has a reputation as a quality supplier, but also because the company is a good corporate citizen. Siemens began activities in Mexico more than 100 years ago with a project to bring electric light to the streets of the capital. Today, there are over 8,000 Siemens employees based in the country.

With a mean annual generation of 1,228.64 GWh and an installed capacity of 750 MW, the El Cajón project will take about 54 months to be completed. Siemens will provide it with 16 PowerLink and 24 SWT 3000 units. Every year Siemens installs a high number of PLC and teleprotection systems. In 2005 the company supplied over 50 substations and had more than 4,000 Power Line Carrier systems in operation throughout Mexico. Siemens projects closely integrate power and communications solutions to give their clients a customized, high-quality system designed to withstand the test of time.

### Benefits

- Network concept that ensures long-term reliability
- Creation of 10,000 direct and indirect jobs
- Improvement of access roads benefiting 40 communities
- Economic benefit of 2 billion pesos
- Annual mean power generation of 1,228 GWh
- Installed capacity of 750 MW
- Annual savings of two million barrels of fuel oil
- Diversification of primary energy sources of the national electric system

### Scope of supply

- PLC PowerLink
- Fiber-optic equipment including
  - PDH: LFH2000
  - SDH: Surpass hit 70
- Multiplexers FMX2
- SWT 3000 analog and digital teleprotection
- Coaxial RF cable
- Coupling units AKE 100





Siemens' work in Mexico is an excellent example of what a long and reciprocal relationship based on mutual trust can accomplish. Because of its special partnership with Mexico's energy companies, Siemens has been instrumental in helping the country build up its energy infrastructure, which has more than 48,000 km of transmission lines and a generation capacity of over 47,000 MW. For the major El Cajón hydroelectric project, Siemens will once again contribute its optimized, state-of-the-art telecommunications solutions.



For the highest degree of reliability CFE decided to invest in SWT 3000 teleprotection units that are linked via fiber optics to the PowerLink PLC terminals.

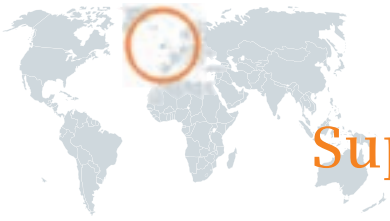

# Supporting growth on the green island

Success story Electricity Supply Board (ESB), Ireland

ESB, Ireland's national power transmission company, signed a framework agreement with Siemens to deliver PLC technology on an ongoing basis. Powerful communication technology is crucial to support boosting economy on the "green island".

## Benefits

- Future-proof technology to master tomorrow's demands
- Reliable cooperation with Siemens as supplier



## The challenge:

At present, Electricity Supply Board (ESB) are experiencing their greatest increase in construction activity since the early years of national electrification. In 2002 a contract for 132 units of PLC was put out to competitive tender. ESB sets very high standards and insists on the highest possible levels of service.

## Our solution:

The Siemens bid was judged to offer the most benefits to ESB from the combined viewpoints of technical and commercial quality. The framework agreement includes the delivery of PLC technology on an ongoing basis. The contract is the latest in a long line of cooperation between ESB and Siemens going back over 75 years in the area of power line carrier technology.

## Scope of supply

- 132 PLC systems
- 132 SWT 3000 protection signaling systems

# Telecommunication network geared for EU future



Success story Natsionalna Elektricheska Kompania EAD (NEK), Bulgaria

## Benefits

- UCTE- and EU-compliant telecommunication system
- Up-to-date, reliable technology
- Network security
- Efficient network management
- Turnkey communication solution tailored to NEK's needs

With plans to join the European Union in 2007, Bulgaria has been stepping up activities toward modernizing its energy production plants and their components. The existing telecommunication network of the National Electric Transmission Company of Bulgaria (NEK) had been based mainly on Power Line Carrier (PLC) systems. These links, however, were no longer sufficient for the needs of the company. The new telecommunication network from Siemens has helped enhance the quality of the NEK's infrastructure.



## The challenge:

To fulfill the NEK's requirements for an updated communication system, a fiber-optic transmission system based on SDH technology needed to be installed. The network in place until the Siemens modernization did not comply with the standards of the Union for Coordination of the Transport of Electricity. The national dispatching center (NDC), the four regional dispatching centers (RDC) and the thirteen branches of the high-voltage network of NEK needed complete dispatching, telecommunication and information facilities. Existing ground wires were to be replaced with OPGWs and used for construction of the main principal ring for the digital transmission network.

## Our solution:

Siemens set up a modern telecommunication system, which allowed Bulgaria not only to comply with UCTE and EU directives but also to open up the electricity market. The requirements for the new communication system were fulfilled after careful site survey and after detailed design of the SDH/PDH and synchronization networks had been developed. By doing this, NEK was able to achieve the national objectives of integrating electrical networks.

## Scope of supply

- Design of the SDH/PDH and synchronization networks
- SCADA/EMS
- UCTE's electronic highway
- LAN, WAN
- High-capacity links between digital PABXs of NEK's telephone network
- Voice and data exchange
- SDH multiservice equipment
- PDH access equipment
- Network management system
- Manufacture, testing, delivery, construction and commissioning

# Major hydroelectricity program

## Success story Peixe Angical hydroelectric power plant, Rio Tocantins, Brazil

Brazil is presently the 10th greatest energy consuming country in the world and the first in South America. Following years of political reform and privatizations, energy demands continue to grow as Brazil's economy develops. When a crippling power short-age rocked the nation in 2001 and led to widespread blackouts, the need for more efficient production and distribution was made strikingly obvious. The result was a nationwide plan to initiate a major hydroelectricity program, which includes a new plant near the city of Peixe.

### Benefits

- One supplier for materials, equipment and services; Installation, documentation, training, field tests, commissioning
- Direct voice communication between operators
- Teleprotection
- Effective data transmission

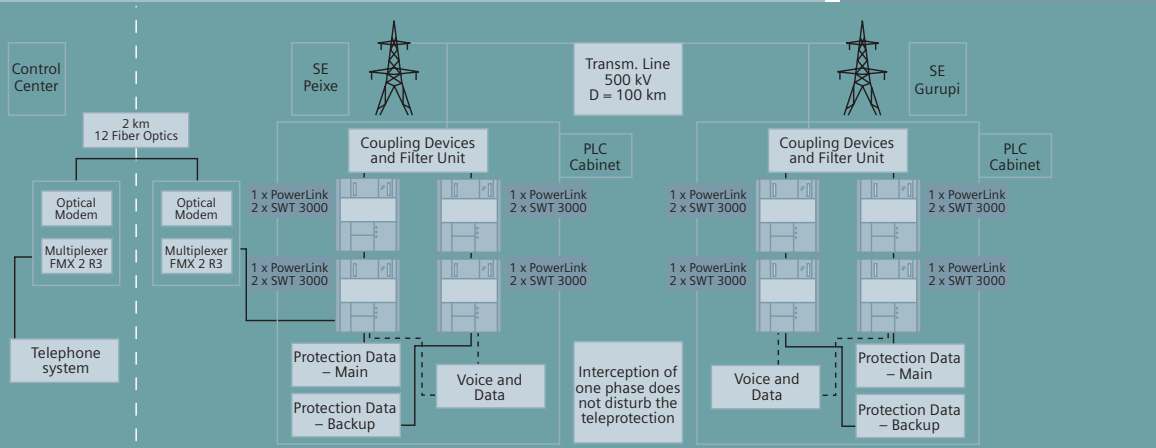

### The challenge:

Siemens was asked to supply the telecommunication needs of the Peixe Angical hydroelectric power plant in Rio Tocantins, Brazil. This plant is scheduled to open in May of 2006 and will have a total installed power of three turbines with 450 MW. This is sufficient to supply the demands of a city with about four million inhabitants. A transmission line of 500 kV will connect the Peixe Angical plant and the 92 km distant Gurupi substation in the north, thereby providing an important link to the north-south connection.

### Our solution:

Siemens installed internal communication systems in the Peixe Angical plant and in the substations Peixe and Gurupi. The PLC equipment enables protection relays, data, fax and voice channels. Control center and the Peixe substation are connected through optic systems with dielectric cable. Optimizing administrative, supervision, control, invoice and maintenance operations, these installations were designed to meet the demands of modern-day communication.

### Scope of supply

- Power Line Carrier – PowerLink with incorporated teleprotection
- “No break” for the 24-hour autonomy and feeding-in 220 V, 60 Hz
- 100 telecommunication devices (analog, digital, mobile)
- Repeater VHF-FM, bidirectional and 4 canals with module
- Controller for interconnection of telephone line
- Fixed antenna omnidirectional VHF
- Metallic tower of 25 m for support of the antenna
- Towers for VHF radio
- Services – manufacture, planning, installing, commissioning, testing and training

# Keeping communications in flow

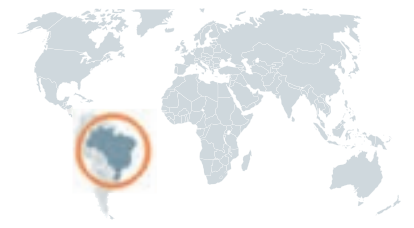

Success story Companhia de Transmissão de Energia Elétrica Paulista (CTEEP), Brazil

## Benefits

- Reliable voice, data and signal transmission
- Proven technology
- Trouble-free solution from a single source

Brazil's economy is growing, and so is the demand for power and communications solutions. Siemens delivered 34 dPLC systems with multiplexers and SWT 3000 protection signaling for a large hydroelectric project, initiated by CTEEP (Companhia de Transmissão de Energia Elétrica Paulista).



## The challenge:

Brazil is one of the most prolific PLC markets worldwide. Its major power utilities like CTEEP have an ongoing demand for this technology, which has proven to be a key medium for the transmission of voice, data and teleprotection signals within their communication networks.

## Our solution:

With the project PLC Lot II, Companhia de Transmissão de Energia Elétrica Paulista (CTEEP) initiated one of the most important Power Line Carrier projects seen in Brazil in years. Siemens – the market leader for digital PLC equipment – built a future-proof solution based on 34 dPLC systems with multiplexers and SWT 3000 protection signaling. In doing this, we helped CTEEP to meet their growing bandwidth demands.

## Scope of supply

- 34 digital PLC systems
- 34 integrated teleprotection systems SWT 3000
- 34 coupling units: phase-phase
- 16 Siemens PMX multiplexers (TDM)
- Commissioning
- Training



# Gearing up for the future

Success story Instituto Costarricense de Electricidad (ICE), Costa Rica

The World Bank has praised Costa Rica as having a healthy economic growth rate and some of the best social indicators on the continent. These factors have resulted in the influx of many high-tech companies and an urgent need for up-to-date and reliable energy networks. Siemens delivered a modern, efficient communication solution geared to grow with the country's requirements.

## Benefits

- Power supply stabilization
- Modern, reliable system
- Higher data transfer rate
- Increased efficiency of voice communication



## The challenge:

Costa Rica's major power transmission utility Instituto Costarricense de Electricidad (ICE) planned to overhaul their telecommunications system. Siemens was asked to modernize the network in order to meet demands for future expansion, accelerate the rate of data transfer and stabilize the power supply.

## Scope of supply

- 42 digital PLC systems
- 42 integrated teleprotection systems SWT 3000
- 24 PMX multiplexers (TDM)
- 84 coupling capacitors (trench)
- 84 line traps Trench (a Siemens Company), on-site training
- Supervision of installation and commissioning
- 137 SWT 3000 signaling protection systems

## Our solution:

Siemens' solution in Costa Rica was to deliver 42 digital PLC systems in 24 substations. These systems had integrated teleprotection equipment, frame relay voice and data multiplexers with PABX functionality using trench line traps and coupling capacitors. This made it possible to transfer data from the substations to the control center at much higher rates than were possible before. Siemens was also able to tremendously increase the efficiency of the voice communication system. To increase the security and availability for the transmission of the various services especially for teleprotection signaling, a redundancy transmission concept has been implemented. ICE ordered additional teleprotection signaling systems for transmission over their digital SDH network. Siemens delivered 137 SWT 3000 Systems with integrated path protection (1+1) using two digital line interfaces with a transmission rate of 2 Mbit/s (acc. to ITU-T G703.6) of the available SDH Multiplexers.



# Successful long-distance link

Success story South China Electric Power Cooperation, China

## Benefits

- Power supply stabilization
- Modern, reliable system
- Siemens as single source for communication technologies
- Significant reduction in maintenance and repair costs due to outstanding reliability

Siemens has a long history of cooperation with China, which began in 1872 with the sales of telegraphs. Today, Siemens is well established in the country, and has recently been awarded an important project to help update China's ever-growing energy network.



## The challenge:

The South China Electric Power Cooperation asked Siemens to install a HVDC line over a length of 960 km in order to increase the reliability of the power supply. This long-distance link necessitated a tailor-made solution to meet the demands of the network.

## Our solution:

The HVDC line was equipped with Siemens PLC technology including protection signaling system. In order to successfully transmit over the distance of 960 km, Siemens installed a repeater in the middle of the transmission line. This project is of great importance to China, since it helps with their goal of a countrywide connected energy transmission system.

## Scope of supply

- 28 PLC systems with a repeater in the middle
- 8 SWT 3000 protection signaling systems
- 3 PABX systems
- 30 km OPGW
- 3 fiber-optic links (34 Mbit/s)
- Commissioning and training

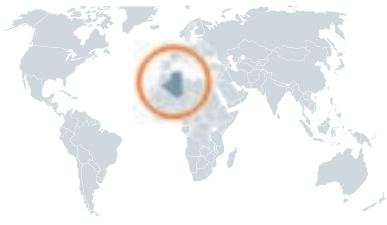

# Algeria modernizes telecommunication network

Success story Sonelgaz, Algeria

Algeria is presently experiencing significant economic expansion due largely to a long period of political stability. This has led to a growing demand not only for additional generation and distribution of energy, but also for more stable and cost-effective communications solutions. Siemens helped tackle the problem with the installation of modern, reliable telecommunication equipment.

## Benefits

- Power supply stabilization
- Modern, reliable system
- Little or no need for coordination on customer's part
- Siemens as single source for all power network and communications technologies



## The challenge:

When Sonelgaz, Algeria's biggest power utility, resolved to upgrade the nation's communication networks, Siemens was asked for assistance with two projects involving Si Mustafa and Ain Quessera. Siemens was already well known to Sonelgaz as their main supplier of PDH, PLC communication and telephone exchanges for many years.

## Our solution:

For these two projects Siemens incorporated a total of 68 PLC systems and additional components such as multiplexers and telephone exchanges. The PDH equipment consists of 2 Mbit/s access multiplexers FMX2 and PDH multiplexers with line equipment OLTE8. For transmission of voice, data and teleprotection signals, PLC technique was used. The unbeatable combination of PLCs together with SWT 3000 teleprotection has vastly improved the quality of the Sonelgaz communication network.

## Scope of Supply

- 68 PLC systems
- 88 SWT 3000 teleprotection systems
- 55 coupling units
- 16 access multiplexers FMX2
- 2 telephone exchanges HiPath 4500
- 8 PDH multiplexers OLTE8
- Commissioning and training



# Customized network management system

Success story of the Saudi Electric Company, Saudi Arabia

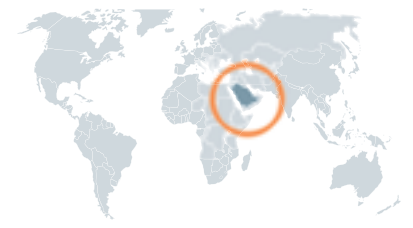

Saudi Arabia's Industry and Electricity Ministry has estimated that the country will require large increases of both power generation and transmission in the near future. The Saudi Electric Company (SEC) turned to Siemens to help them meet their growing communication network needs.

## Benefits

- Power supply stabilization
- Modern, reliable system
- High productivity through seamless integration
- Significant reduction in maintenance and repair costs due to outstanding reliability



## The challenge:

The SEC awarded Siemens with a contract to deliver, install, test and commission a fiber-optic communication network in the two major western cities of Mecca and Medina. Each city was to have a network management system in a ring topology.

## Our solution:

Siemens provided the SEC with a system comprised of eleven 48-V DC supply systems and a repeater station. This customized turnkey solution helps stabilize energy supply and optimizes the telecommunication system. The scope of supply included telecom cables, services, factory acceptance test, incl. installation and commissioning of proposed network, engineering, training.

## Scope of supply

- 11 48-V DC supply systems
- Building of a repeater station
- Supply
- Installation
- Testing and commissioning
- 16 SDH STM-16 (hiT 7070) nodes
- 8 main distribution frame units
- 46 primary data voice multiplexer units
- 16 digital distribution frame units
- 2 element management system units (NCT)
- 1 network management system unit (TNMS)
- 2 local craft terminals for SDH units
- 2 local craft terminals for DVM units
- 1 primary reference clock
- 2 routers
- 2 STM-1 electrical IF modules of Nortel OM 4150 units



# Establishing a dependable telecommunication system

Success story Power Holding Company, Nigeria

Although Nigeria has a power-generating capacity of 4,000 MW, actual power generation was often less than half that amount and the country was plagued with frequent power outages and interruptions. Understandably, one of the main concerns of the Power Holding Company of Nigeria (PHCN) was that a reliable telecommunications system be established – and Siemens delivered just that.

## Benefits

- One-source solution – complete portfolio
- Turnkey system including design and engineering
- Planned for long-term investment
- Tailor-made for the customer
- Fast time to market



## The challenge:

For the PHCN it was vital that Siemens install a high-quality, dependable communication system that would be a long-term investment. The project was to be completed in three stages and would involve almost one hundred substations as well as the control center (LDC).

## Our solution:

Siemens provided the PHCN with a modern transmission and distribution system including SDH, PDH, PLC for voice and data communication, protection signaling and telephone switching equipment (PABXs). For sending data between the substations and the control center, three transmission media were used. These included fiber-optic cable integrated in the OPGW line, a digital and analog PLC system and digital radio equipment – all combining to provide a telecommunication system built for tomorrow.

## Scope of supply

- 146 PowerLink PLCs
- 86 teleprotection systems SWT 3000
- Connection of remote subscribers via VFS module
- Integrated teleprotection
- Connection of telephone exchanges via E&M-FXO interfaces
- Point-to-point channel routing over the entire PLC network

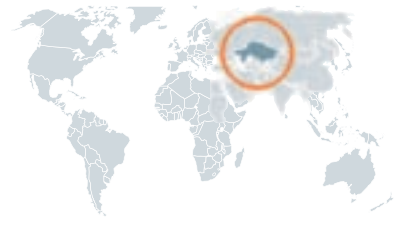

# Transmission Rehabilitation Project utilizes latest technology

Success story KEGOC (Kazakhstan Electricity Grid Operating Company), Kazakhstan

## Benefits

- System can be easily upgraded for future communication requirements
- System optimization by telecontrol/SCADA information transmission V.24 PLC
- Analog PLC E&M voice, partly 100 bound data
- Digital PLC with dynamic data pump and voice compression multiplexers
- Analog PowerLink PLC can be upgraded to digital PLC
- Single-source supplier – complete portfolio
- Minimized risk and long-term investment

Kazakhstan's national power utility KEGOC (Kazakhstan Electricity Grid Operating Company) decided to update its energy network to include the latest communication technologies. Although the country has significant natural gas and oil reserves, the sector's infrastructure had been deteriorating. The new Siemens system helps strengthen not only the energy network, but also Kazakhstan's importance as a power bridge between Russia and Central Asia.



## The challenge:

The Kazakhstan Electricity Transmission Rehabilitation Project was set up to rehabilitate KEGOC's transmission system and improve power system dispatch control. The energy infrastructure in Kazakhstan had undergone widespread deterioration over the last decades, which led to frequent power shortages and electricity losses over the distribution channels.

## Our solution:

Siemens set up a total network of 250 PLC systems involving telecontrol and SCADA. A highlight of the project was the use of SWT 3000/MCM for relay protection and antiemergency automation, which helps protect KEGOC's power network. Kazakhstan has the potential to become a major energy producer and with Siemens solutions it has the perfect partner to help it on its way.

## Scope of supply

- 250 PLC systems
- 41 Siemens PMX multiplexers
- 150 cabinets
- Integrated protection signaling systems
- SWT 3000 with MCM (multicommand module) for relay protection and energy automation
- Training of 12 KEGOC specialists in Fürth, Germany

Siemens AG  
Power Transmission and Distribution  
Energy Automation  
P.O. Box 48 06  
90026 Nuremberg  
Germany

[www.siemens.com/energy-automation](http://www.siemens.com/energy-automation)

For questions on power transmission and distribution, please contact our Customer Support Center, 24 hours a day.  
Tel.: +49 180 / 524 70 00  
Fax: +49 180 / 524 24 71  
(Subject to charge: e.g. 12 ct/min)  
E-mail: [support.energy@siemens.com](mailto:support.energy@siemens.com)  
[www.siemens.com/energy-support](http://www.siemens.com/energy-support)

Subject to change without prior notice  
Order No. E50001-U310-A5-X-7600  
Printed in Germany  
Dispo 06200  
GB 06736 101733 DS 08061.0

The information in this document contains general descriptions of the technical features, which may not always be available.  
An obligation to provide the respective performance feature shall exist only if expressly agreed in the terms of contract.