

RuggedSwitch™ RSG2100

19-Port Modular Managed Ethernet Switch with Gigabit Uplink Ports



Installation Guide

www.ruggedcom.com

Federal Communications Commission Radio Frequency Interference Statement

This equipment has been tested and found to comply with the limits for a Class A digital device pursuant to Part 15 of the FCC Rules. These limits are designed to provide reasonable protection against harmful interference when the equipment is operated in a commercial environment. This equipment generates, uses and can radiate radio frequency energy and, if not installed and used in accordance with the instruction manual, may cause harmful interference to radio communications. Operation of this equipment in a residential area is likely to cause harmful interference in which case the user will be required to correct the interference on his own expense.

CAUTION

This product contains a laser system and is classified as a “CLASS 1 LASER PRODUCT”

CAUTION

Use of controls or adjustments or performance of procedures other than those specified herein may result in hazardous radiation exposure. This product contains no user serviceable parts.

Attempted service by unauthorized personnel shall render all warranties null and void.

Changes or modifications not expressly approved by RuggedCom Inc. could void the user's authority to operate the equipment.

Should this device require service see the “Warranty and Service” section of this guide.

IMPORTANT

The RSG2100 family of products should be installed in a **restricted access location** where access can only be gained by service personnel or users who have been instructed about the reasons for the restrictions applied to the location and about any precautions that shall be taken; and access is through the use of a tool or lock and key, or other means of security, and is controlled by the authority responsible for the location.

Trademarks:

Ethernet is a trademark of Xerox Corporation

RuggedSwitch, RuggedRated, ROS and eRSTP are trademarks of RuggedCom® Inc.

Table of Contents

1	Table of Figures	4
2	Table of Tables.....	4
3	Product Overview	5
3.1	Functional Overview.....	5
3.2	Feature Highlights.....	5
3.3	Mounting Flexibility	7
3.4	Ethernet Panel Description	8
3.4.1	Fiber Optical Transceiver Orientation and Connection	9
3.5	Display Panel Description.....	11
4	Installation	13
4.1	Rack Mounting.....	13
4.2	Panel and DIN Rail Mounting	14
4.3	Power Supply Wiring and Grounding.....	15
4.3.1	AC Power Supply Wiring Examples	17
4.3.2	DC Power Supply Wiring Examples	18
4.3.3	Dual Power Supplies – DC and AC Inputs.....	19
4.4	Dielectric Strength (HIPOT) Testing.....	20
4.5	Failsafe Alarm Relay Wiring and Specifications.....	21
4.6	Console Port Wiring	22
4.7	RJ45 Twisted-Pair Data Ports	23
4.8	Gigabit Ethernet 1000Base-Tx Cabling Recommendations	24
4.9	Pluggable optics – Installation, removal, and precautions.....	25
4.9.1	Module Insertion – GBICs and SFPs.....	25
4.9.2	GBIC Module Removal	26
4.9.3	SFP Module Removal	26
5	Technical Specifications	27
5.1	Power Supply Specifications	27
5.2	Failsafe Relay Specifications	27
5.3	Networking Standards Supported	27
5.4	Twisted-Pair Port Specifications.....	28
5.5	Fiber Optical Specifications.....	29
5.5.1	Fast Ethernet (10/100 Mbps) Optical Specifications	30
5.5.2	Gigabit Ethernet (1000 Mbps) Optical Specifications.....	31
5.6	Type Test Specifications.....	34
5.7	Operating Environment.....	34
5.8	Mechanical Specifications	35
6	Agency Approvals	36
7	Warranty.....	36

1 Table of Figures

Figure 1: RSG2000 Rack mount chassis orientation options – Front and rear mount.....	7
Figure 2: Ethernet, LED Status, and Power Panels	8
Figure 3: Ethernet panel LED description.....	8
Figure 4: 10FL ST connector.....	9
Figure 5: 100FX MTRJ connector	9
Figure 6: 100FX / 1000LX LC connector.....	9
Figure 7: 100FX / 1000LX SC connector	9
Figure 8: 100FX / 1000LX ST connector.....	10
Figure 9: 1000LX GBIC Module and	10
Figure 10: 1000LX SFP (mini-GBIC) Module	10
Figure 11: RSG2000 LED Display Panel.....	11
Figure 12: RS2000 Family 19" Rack Mount Adapters	13
Figure 13: Rack mount adapter mounting location.....	13
Figure 14: RSG2000 PANEL/DIN RAIL mounting diagram with.....	14
Figure 15: RSG2000 Series Philips Screw Terminal Block	15
Figure 16: RSG2000 Series Phoenix Plug Terminal Block.....	15
Figure 17: AC Power supply wiring examples.....	17
Figure 18: DC Power supply wiring examples.....	18
Figure 19: DC And AC power supply wiring examples.....	19
Figure 20: Dielectric Strength (HIPOT) Testing.....	20
Figure 21: Failsafe Alarm Relay Wiring	21
Figure 22: Console port location on display board	22
Figure 23: RSG200 Console cable.....	22
Figure 24: RJ45 port pins configuration.	23
Figure 25: SFP Orientation for top row and bottom row ports	25
Figure 26: Locking latch location on GBIC optical modules	26
Figure 27: SFP Bail Latch location	26
Figure 28: SFP Removal.....	26

2 Table of Tables

Table 1: LED Display – Device status LED behavior definition	11
Table 2: LED Display - Port LED behavior definition.....	12
Table 3: RSG2000 Power terminal block connection description.....	16
Table 4: RS232 over RJ45 console cable pin-out	22
Table 5: RJ45 Ethernet pin-out assignment	23
Table 6: Cabling categories and 1000BaseTx compliance defined.....	24
Table 7: Fast Ethernet optical specifications	30
Table 8: Gigabit Ethernet optical specifications.....	31

3 Product Overview

3.1 Functional Overview

The **RuggedSwitch™ RSG2100** is an industrially hardened, fully managed, modular, Ethernet switch specifically designed to operate reliably in electrically harsh and climatically demanding utility substation and industrial environments. The RSG2100's superior ruggedized hardware design coupled with the RuggedSwitch™ Operating System (ROS) provides improved system reliability and advanced networking features making it ideally suited for creating Ethernet networks for mission-critical, real-time, control applications.

The RSG2100's modular flexibility offers 10BaseFL/100BaseFX/1000BaseX fiber and 10/100/1000BaseTX copper port combinations. Optional front or rear mount connectors make the RSG2100 highly versatile for any application and can support multiple fiber connectors (ST, MTRJ, LC, SC) without loss of port density. The RSG2100 is packaged in a rugged galvanized steel enclosure with industrial grade DIN, panel, or 19" rack-mount mounting options.

3.2 Feature Highlights

Ethernet Ports

- 3-Gigabit Ethernet ports supporting copper and fiber media
- 16-Fast Ethernet ports supporting copper and fiber media
- Modular port design for unrivaled flexibility
- Multimode and Singlemode fiber support
- Bi-directional simplex (single strand) fiber support
- Full compliance with IEEE: 802.3, 802.3u & 802.3z
- Non-blocking, store and forward switching
- Full duplex operation and flow control (IEEE 802.3x)
- Industry standard fiber optical connectors: LC, SC, SFP
- Long haul optics allow Gigabit distances up to 70km

RuggedRated™ for Reliability in Harsh Environments

- Meets IEEE 1613 (electric utility substations)
- Exceeds IEC 61850-3 (electric utility substations)
- Exceeds IEEE 61800-3 (variable speed drive systems)
- Exceeds IEC 61000-6-2 (generic industrial environment)
- Exceeds NEMA TS-2 (traffic control equipment)
- -40 to +85°C operating temperature (no fans)
- Conformal coated printed circuit boards (optional)
- 18 AWG galvanized steel enclosure

Universal Power Supply Options

- Fully integrated, dual-redundant (optional) power supplies
- Universal high-voltage range: 88-300VDC or 85-264VAC
- Popular low voltage DC ranges: 12, 24 or 48 VDC
- Terminal blocks for reliable maintenance free connections
- CSA/UL 60950 safety approved to +85°C

Simple Plug and Play Operation

- Automatic learning of up to 8192 MAC addresses
- Auto-negotiation on all 10/100/1000BaseTX ports
- Auto-MDI/MDIX (crossover) on all 10/100BaseTX ports
- LED indicators for link, activity and speed

Rugged Operating System (ROS™) Advanced Network Management

- Enhanced Rapid Spanning Tree (eRSTP™)
- Quality of Service (802.1p) for real-time traffic
- Port rate limiting: 128kbps - 8Mbps
- VLAN (802.1q) with double tagging
- IGMP Snooping for multicast filtering
- Port configuration, status, statistics, mirroring, security
- Loss of link management on fiber ports
- Web-based, Telnet, CLI management interfaces
- SNMP v2 and RMON
- Rich set of diagnostics with logging and alarms

3.3 Mounting Flexibility

The RSG2000 series of products have been designed with maximum mounting and display flexibility. Customers can order an RSG2000 series switch that can be mounted in a standard 19" rack, 1" DIN Rail, or directly onto a panel. For rack mount installations, the RSG2000 series can be ordered with connectors on the front of the unit, or can be located on the rear of the chassis to allow for all data and power cabling to be installed and connected at the rear of the rack. See Figure 1 for rack mount orientation examples.

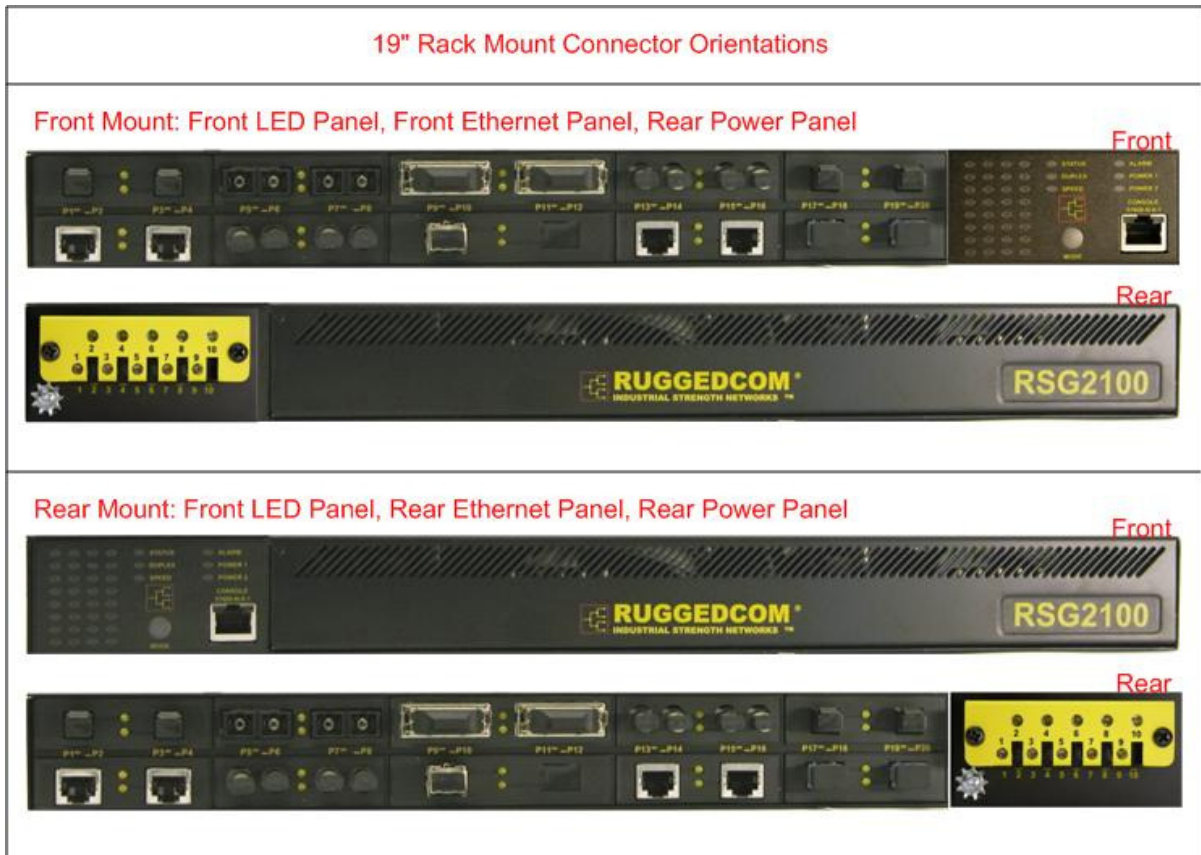

Figure 1: RSG2000 Rack mount chassis orientation options – Front and rear mount.

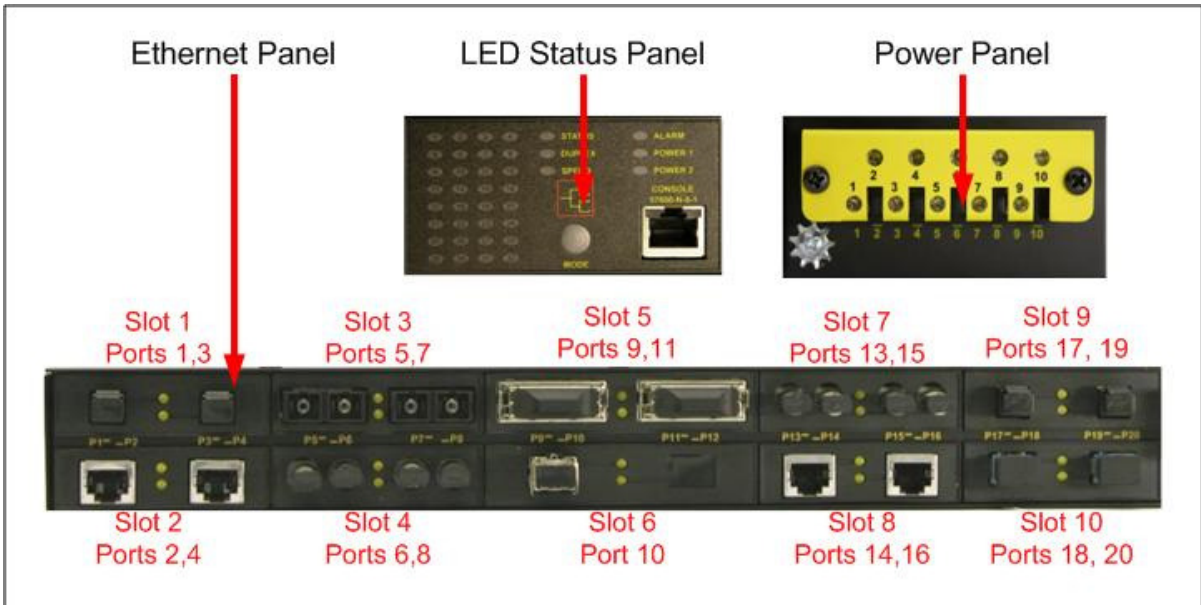

Figure 2: Ethernet, LED Status, and Power Panels

3.4 Ethernet Panel Description

Each Ethernet module is equipped with two LEDs that indicate link/activity status information. The LED will be solid for ports with link, and will blink for activity. The diagram in Figure 3 highlights the port and the associated link/activity LED.

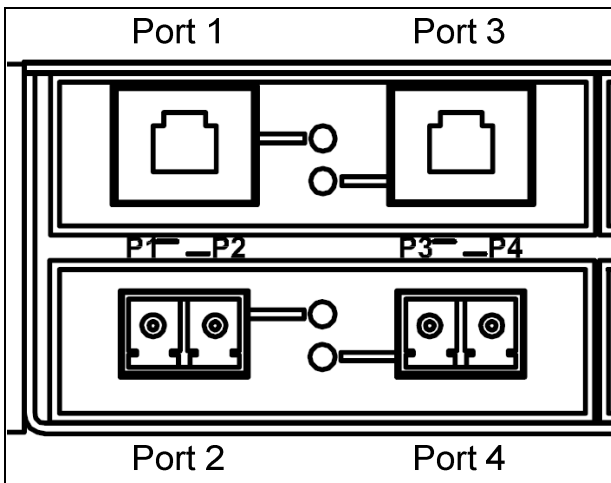

Figure 3: Ethernet panel LED description

3.4.1 Fiber Optical Transceiver Orientation and Connection

Depending on the order code of the product, the RSG2000 series products can be equipped with several different types of fiber optic ports. The Transmit (TX) and Receive (RX) connections of each port must be properly connected and matched for proper link and operation. Modules populated on the top row of the device typically have locking mechanisms or tabs towards the top of the unit. Modules located on the bottom row of the device have locking mechanisms or tabs towards the bottom of the device.

The drawings in the following figures show each fiber optical connector style with a side and top view to allow the user to identify the proper cable connection orientation. If modules are populated on the bottom row of the device, the transceiver orientation will be reversed (ie RX and TX will be reversed).

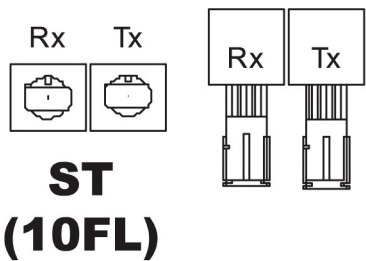

Figure 4: 10FL ST connector

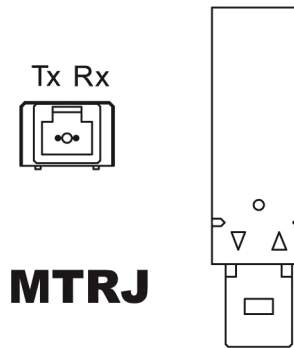

Figure 5: 100FX MTRJ connector

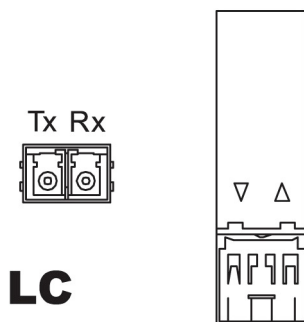

Figure 6: 100FX / 1000LX LC connector

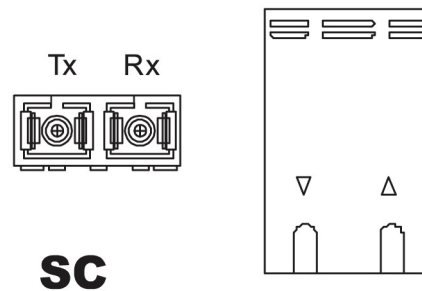
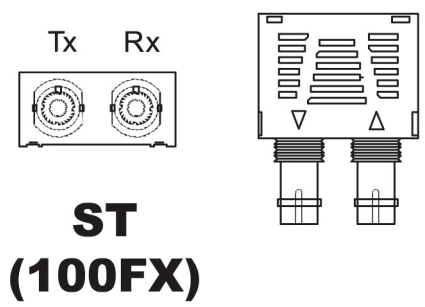
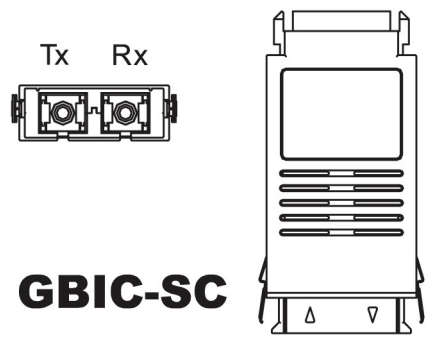

Figure 7: 100FX / 1000LX SC connector



**ST
(100FX)**

Figure 8: 100FX / 1000LX ST connector



GBIC-SC

Figure 9: 1000LX GBIC Module and SC connector

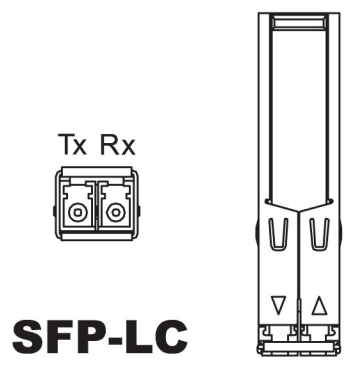

SFP-LC

Figure 10: 1000LX SFP (mini-GBIC) Module and LC connector

3.5 Display Panel Description

The RSG2000 series products are equipped with a versatile display panel, shown in Figure 11, which is designed to provide quick status information for each port, as well as the entire device to allow for simple diagnostics and troubleshooting. It features:

- RS232 console port for 'out of band' console access and configuration
- Power supply and Alarm status indicators
- Convenient port status indicators conveying Link-Activity, Duplex, or Speed via push-button control.
- System reset via push-button if held for 5 seconds

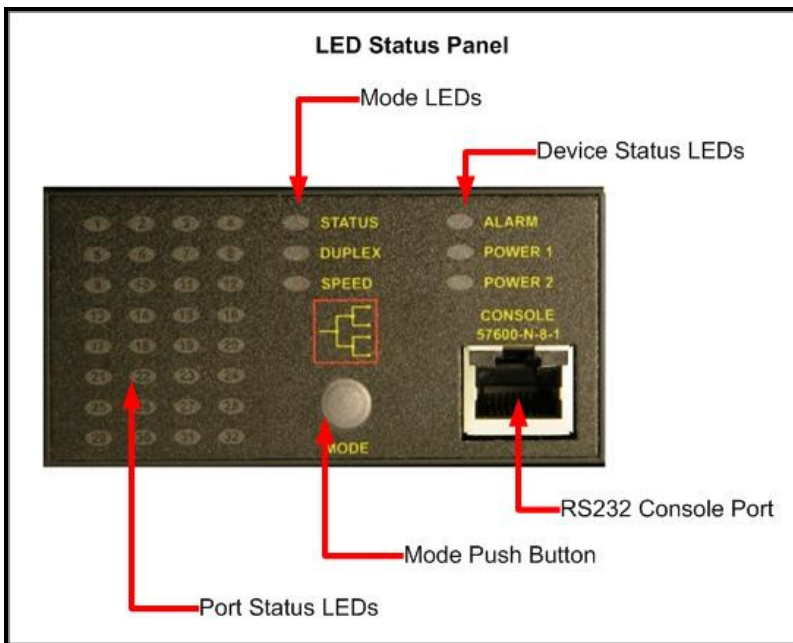

Figure 11: RSG2000 LED Display Panel

Device status LEDs exist to provide a quick visual indicator to operators for operational status of the unit. Table 1 defines the possible LED colours and the corresponding description.

LED	Colour	Description
PS1 / PS2	Green	Power supply operating normal
	Red	Power supply failure
	Off	No power supply installed
Alarm	Red	Alarm exist – login to console to determine alarm code
	Off	No alarms exist

Table 1: LED Display – Device status LED behavior definition

The port-based LEDs can be cycled between three display modes: Status, Duplex, and Speed. Pushing the mode button causes the display mode to be cycled. Table 2 defines the possible port LED colours and the corresponding description.

Mode	Colour	Description
Status	Green (Solid)	Link
	Green (Blinking)	Activity
	Off	No link
Duplex	Green (Solid)	Full-Duplex operation
	Orange (Solid)	Half-Duplex operation
	Off	No link
Speed	Green (Blinking)	1000Mb/s
	Green (Solid)	100Mb/s
	Orange (Solid)	10Mb/s
	Off	No link

Table 2: LED Display - Port LED behavior definition

4 Installation

4.1 Rack Mounting

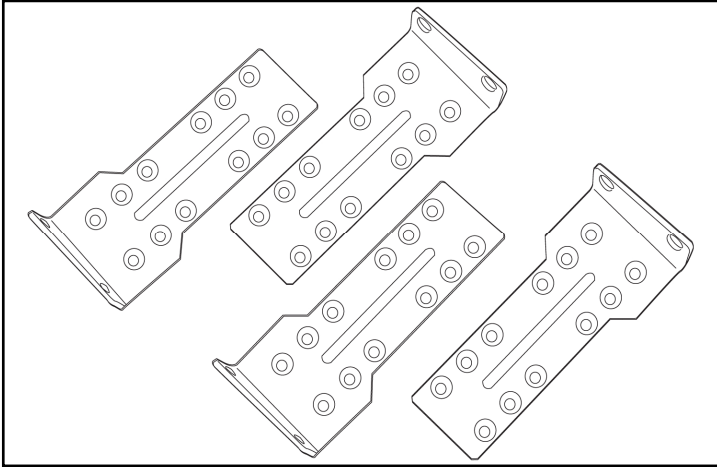

Figure 12: RS2000 Family 19" Rack Mount Adapters

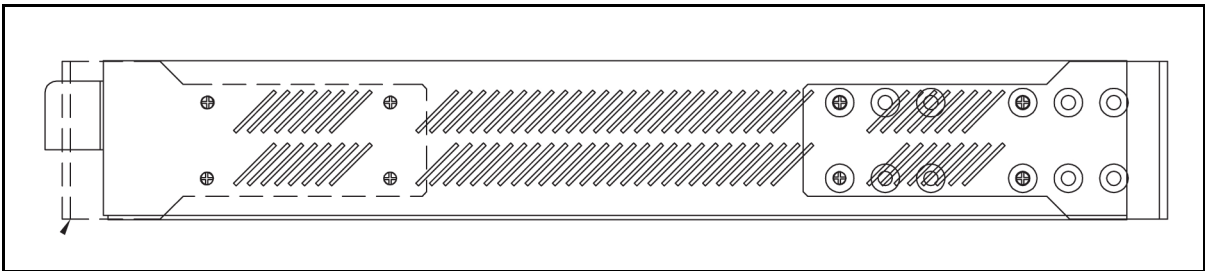

Figure 13: Rack mount adapter mounting location

The RSG2000 family of products can be rack mounted using the included rack mount adapter assemblies shown in Figure 12. Secure the one rack mount adapter to the front of each side of the chassis using the included black PAN head philips screws in the positions shown in Figure 14. The entire chassis can then be mounted to a standard 19" rack. An additional two rack mount adapters are included to optionally secure the rear of the chassis in high-vibration, or seismically active locations.

Note: Since heat within the RSG2100 is channeled to the enclosure, it is recommended that 1 rack unit of space (1.75") be kept unpopulated and free of equipment above each RSG2100 series product to allow for a small amount of convective airflow. Although forced airflow is not necessary, any increase in airflow will result in a reduction of ambient temperature that will improve long-term reliability of all equipment mounted within the rack space.

4.2 Panel and DIN Rail Mounting

The RSG2000 series products can be ordered as a Panel/DIN mount chassis. Both options involve the use of the panel/DIN adapters to be mounted on each side of the chassis enclosure. The adapter allows for the chassis to be mounted on the standard 1" DIN rail using the grooves in the adapter, secured using the included philips screw. See Figure 14 for a PANEL/DIN mount diagram.

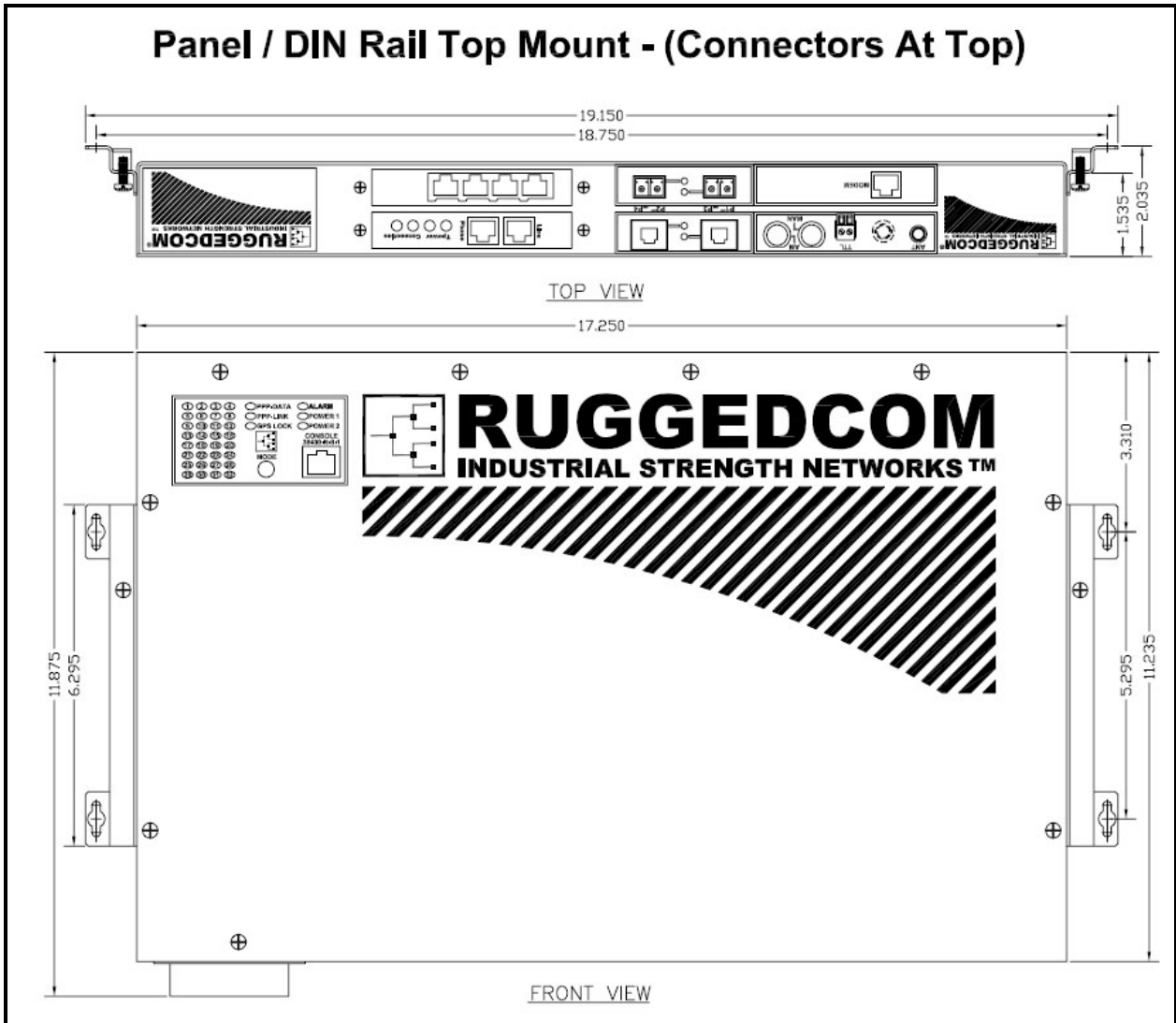

Figure 14: RSG2000 PANEL/DIN RAIL mounting diagram with

4.3 Power Supply Wiring and Grounding

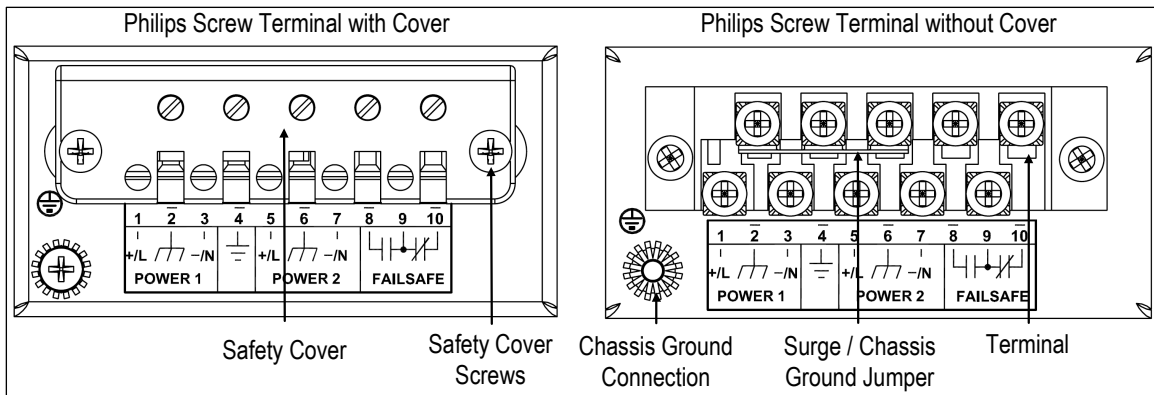

Figure 15: RSG2000 Series Philips Screw Terminal Block

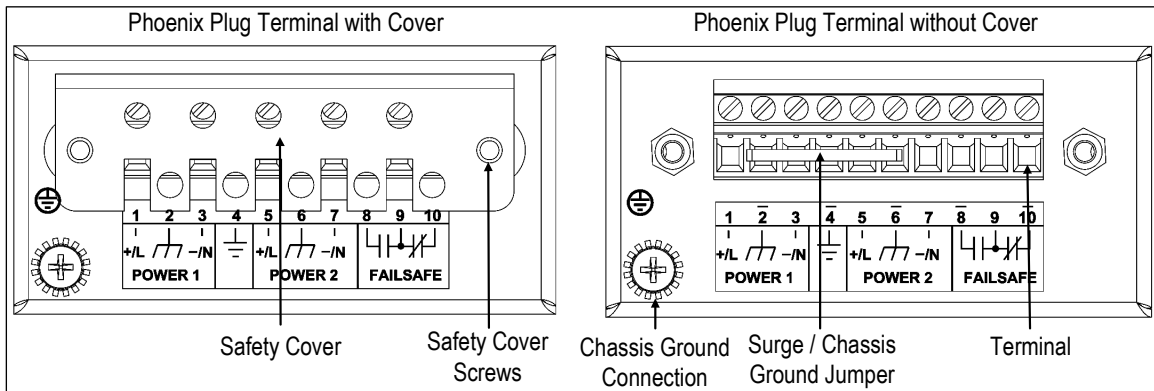

Figure 16: RSG2000 Series Phoenix Plug Terminal Block

The RSG2000 Family supports dual redundant power supplies – “Power Supply 1 (PS1)” and “Power Supply 2 (PS2)”. The connections for PS1, PS2 and the fail-safe relay are located on the terminal block as shown in Figure 15 and Figure 16.

The RSG2000 Family can be equipped with either a Philips Screw Terminal Block or a Phoenix Plug Terminal Block. The Philips Screw Terminal Block has Philips screws with a compression plate allowing either bare wire connections or crimped terminal lugs. We recommend the use of #6 size ring lugs to ensure secure, reliable connections under severe shock or vibration. Both terminal blocks have a safety cover which must be removed via two Phillips screws before connecting any wires. The safety cover must be re-attached after wiring to ensure personnel safety. Refer to Table 3 below for a description of each terminal as well as sections 4.3.1 through 4.3.3 for wiring examples.

Terminal #	Description	Usage
1	PS1 Live / +	PS1 Live / + is connected to the positive (+) terminal if the power source is DC or to the (Live) terminal if the power source is AC.
2	PS1 Surge Ground	PS1 Surge Ground is connected to the Chassis Ground via a jumper on the terminal block. Surge Ground is used as the ground conductor for all surge and transient suppression circuitry. NOTE: Surge Ground must be disconnected from Chassis Ground during HIPOT (dielectric strength) testing.
3	PS1 Neutral / -	PS1 Neutral / - is connected to the negative (-) terminal if the power source is DC or to the (Neutral) terminal if the power source is AC.
4	Chassis Ground	Chassis Ground is connected to the Safety Ground terminal for AC inputs or the equipment <i>ground bus</i> for DC inputs. Chassis ground connects to both power supply surge grounds via a removable jumper.
5	PS2 Live / +	PS2 Live / + is connected to the positive (+) terminal if the power source is DC or to the (Live) terminal if the power source is AC.
6	PS2 Surge Ground	PS2 Surge Ground is connected to the Chassis Ground via a jumper on the terminal block. Surge Ground is used as the ground conductor for all surge and transient suppression circuitry. NOTE: Surge Ground must be disconnected from Chassis Ground during HIPOT (dielectric strength) testing.
7	PS2 Neutral / -	PS2 Neutral / - is connected to the negative (-) terminal if the power source is DC or to the (Neutral) terminal if the power source is AC.
8	Relay NO Contact	Normally open, failsafe relay contact.
9	Relay Common	Failsafe relay common contact.
10	Relay NC Contact	Normally closed, failsafe relay contact.

Table 3: RSG2000 Power terminal block connection description

4.3.1 AC Power Supply Wiring Examples

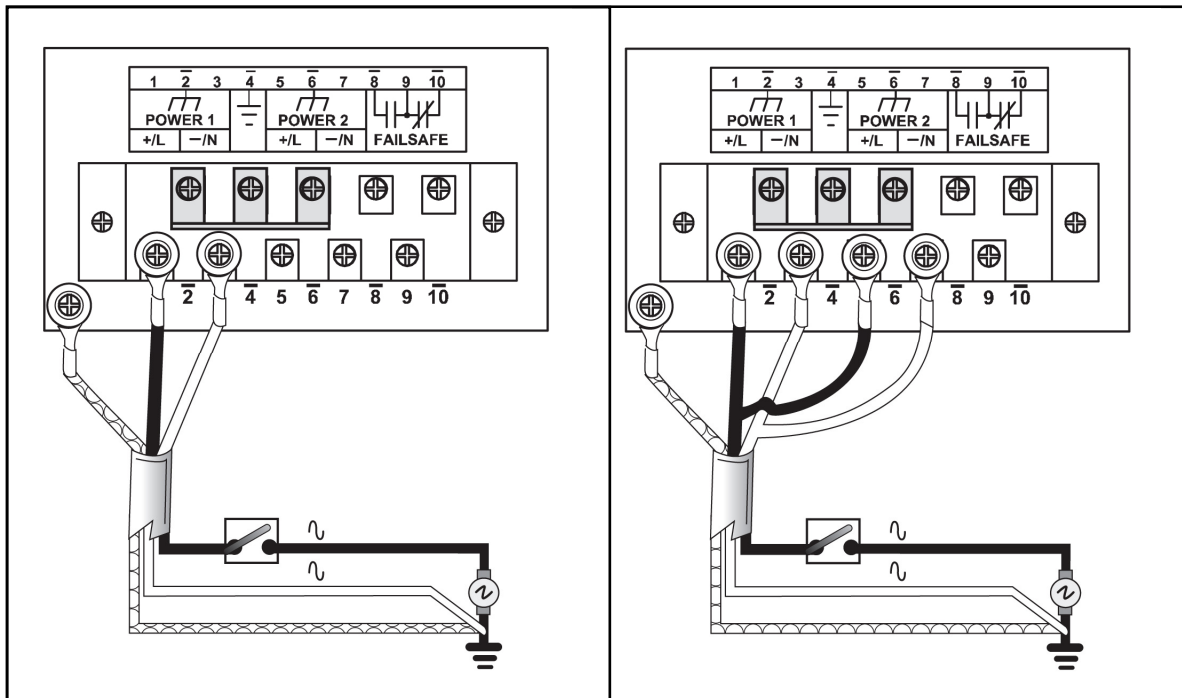

Figure 17: AC Power supply wiring examples

Notes:

1. **100-240VAC rated equipment: A 250VAC appropriately rated circuit breaker must be installed within 3m of unit.**
2. **Equipment must be installed according to the applicable country wiring codes.**
3. **When equipped with two HI voltage power supplies, independent AC sources can be used to power the product for greater redundancy.**

4.3.2 DC Power Supply Wiring Examples

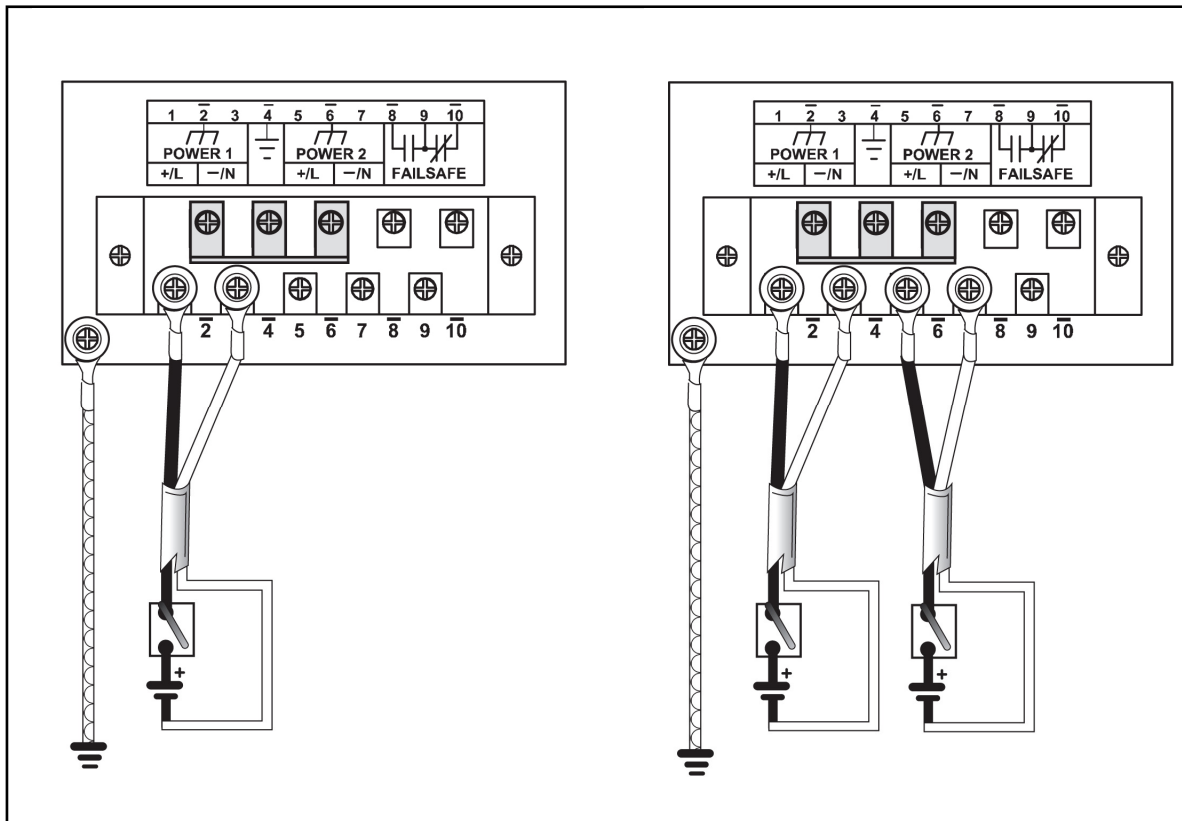

Figure 18: DC Power supply wiring examples

Notes:

1. **88-300VDC rated equipment: A 300VDC appropriately rated circuit breaker must be installed within 3m of unit.**
2. **A circuit breaker is not required for 12, 24 or 48 VDC rated power supplies.**
3. **For dual DC power supplies, Separate circuit breakers must be installed and separately identified.**
4. **Equipment must be installed according to the applicable country wiring codes.**

4.3.3 Dual Power Supplies – DC and AC Inputs

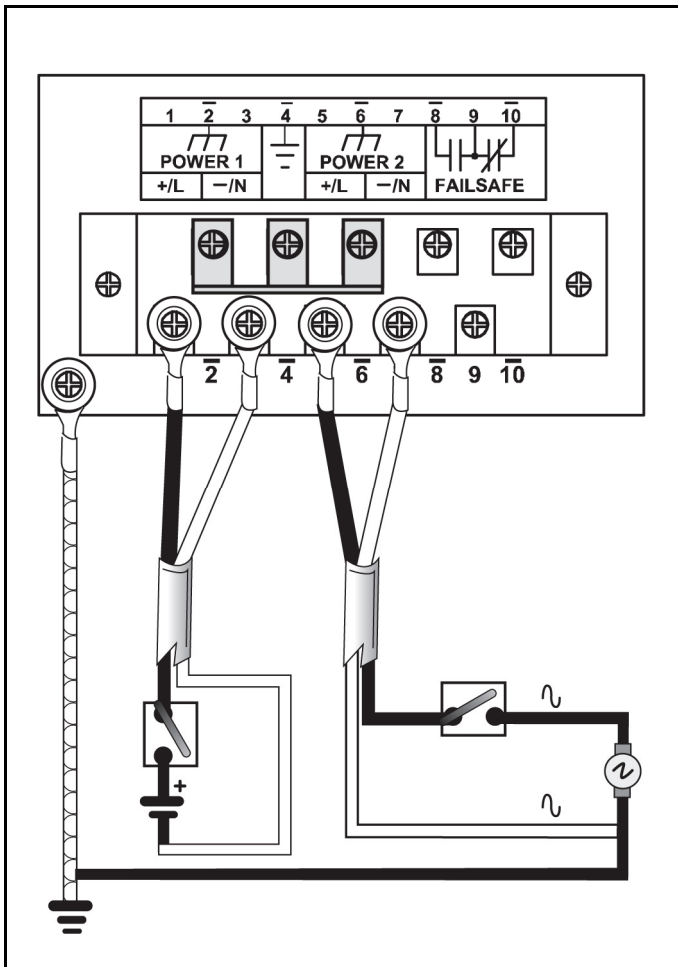

Figure 19: DC And AC power supply wiring examples

Notes:

1. **88-300VDC rated equipment:** A 300VDC appropriately rated circuit breaker must be installed within 3m of unit.
2. **100-240VAC rated equipment:** A 250VAC appropriately rated circuit breaker must be installed within 3m of unit.
3. A circuit breaker is not required for 48 or 24VDC rated power supplies.
4. Separate circuit breakers must be installed and separately identified.
5. Equipment must be installed according to the applicable country wiring codes.

4.5 Failsafe Alarm Relay Wiring and Specifications

The “Failsafe” output relay is provided to signal critical error conditions that may occur on the RSG2100 series switches. The contacts are energized upon power up of the unit and remain energized until a critical error occurs. The proper relay connections are shown in Figure 21. One common application for this output is to signal an alarm if a power failure or removal of control power occurs. The failsafe relay current and power handling capabilities are defined in the technical specification section.

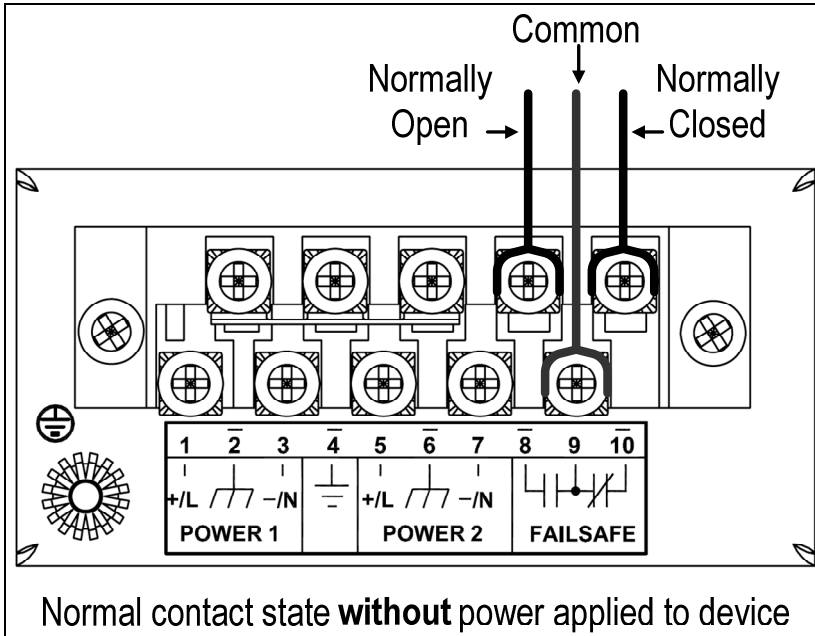

Figure 21: Failsafe Alarm Relay Wiring

4.6 Console Port Wiring

A RS232 console port for configuration and management of the device is located on the LED display module shown in Figure 22. This port is intended to be a temporary connection during initial configuration or troubleshooting and allows for direct access to the serial-based management console. The connection is made using the DB9-Female to RJ45 console cable included in the device packaging shown in Figure 23. Console connection settings are: 57600 baud, no parity bits, 8 data bits, and 1 stop bit.

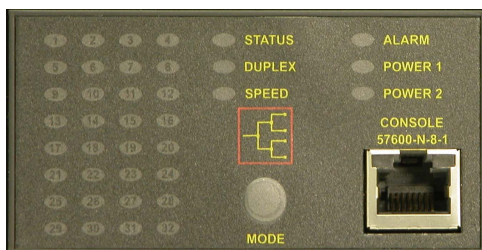

Figure 22: Console port location on display board

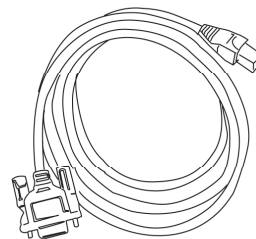

Figure 23: RSG200 Console cable

For user reference, the console cable pin-out is show in Table 5.

RuggedCom RS232 over RJ45 pin-out specification		
<i>Signal Name (PC is DTE)</i>	<i>DB9- Female</i>	<i>RJ45 Male</i>
DCD – Carrier detect	1	2
RxD – Receive data (to DTE)	2	5
TxD – Transmit data (from DTE)	3	6
DTR – Data terminal ready	4	3
Signal GND	5	4
DSR – Data set ready	6	1*
RTS – Ready to send	7	8
CTS – Clear to send	8	7
RI – Ring Indicator	9	1*

Table 4: RS232 over RJ45 console cable pin-out

After initial configuration, the RuggedSwitch device can be configured via a number of new mechanisms such as Telnet, and the built-in web server. Consult the RuggedSwitch ROS User Guide for further details.

NOTE: This port is not intended to be a permanent connection and the cable shall be less than 2m (6.5 ft) in length.

4.7 RJ45 Twisted-Pair Data Ports

The RSG2100 may have several 10/100BaseTX ports that allow connection to standard CAT-5 UTP cable with RJ45 male connectors. All RSG2100 RJ45 RuggedSwitch products feature auto-negotiating, auto-polarity, and auto-crossover functions. The RJ45 receptacles used can accept and take advantage of screened (commonly known as “shielded”) cabling. The figure below shows the RJ45 port pins configuration.

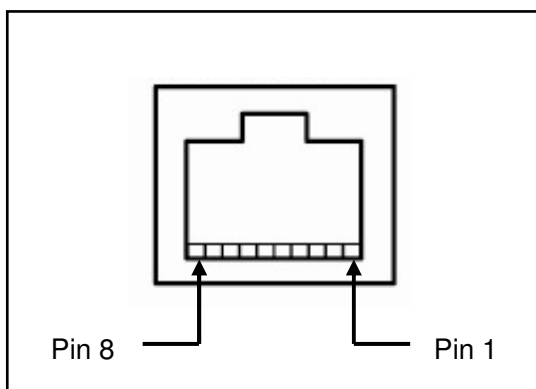

Figure 24: RJ45 port pins configuration.

10/100Base-TX Pin-out	
Pin	Description
1	RX +
2	RX -
3	TX +
6	TX -
4, 5, 7, 9	NC

Table 5: RJ45 Ethernet pin-out assignment

NOTE: RuggedCom does not recommend the use of CAT-5 (10/100Base-TX communications) cabling of any length for critical real-time substation automation applications. However, transient suppression circuitry is present on all copper ports to protect against damage from electrical transients and to ensure IEC 61850-3 and IEEE 1613 Class 1 conformance. This means that during the transient event communications errors or interruptions may occur but recovery is automatic. RuggedCom also does not recommended to use these ports to interface to field devices across distances which could produce high levels of ground potential rise, (i.e. greater than 2500V) during line to ground fault conditions.

4.8 Gigabit Ethernet 1000Base-Tx Cabling Recommendations

The IEEE 802.3ab Gigabit Ethernet standard defines 1000Mbit/s Ethernet communications over distances of up to 100 meters using 4 pairs of category 5 (or higher) balanced unshielded twisted-pair cabling. For wiring guidelines, system designers and integrators should refer to the Telecommunications Industry Association (TIA) TIA/EIA-568-A wiring standard that characterizes minimum cabling performance specifications required for proper Gigabit Ethernet operation. To ensure reliable, error-free data communications, new and pre-existing communication paths should be verified for TIA/EIA-568-A compliance. Table 6 summarizes cabling standards available today

Cabling Category	1000BaseTx Compliant	Required action
< 5	No	New wire infrastructure required
5	Yes	Verify TIA/EIA-568-A compliance
5e	Yes	No action required. New installations should be designed with Category 5e components or higher
6	Yes	No action required
> 6	Yes	Connector and cabling standards to be determined.

Table 6: Cabling categories and 1000BaseTx compliance defined.

In general the following recommendations should be followed for copper data cabling in high electrical noise environments:

- Data cable lengths should be as short as possible, ideally limited to 3m (10ft) in length. Copper data cables should not be used for inter-building communications.
- Power and data cables should not be run in parallel for long distances, and ideally should be installed in separate conduits. Power and data cables should intersect at 90° angles when necessary to reduce inductive coupling.
- Shielded/screened cabling can optionally be used. The cable shield should be grounded at one single point to avoid the generation of ground loops.

4.9 Pluggable optics – Installation, removal, and precautions

The RSG2000 series of products can be ordered with pluggable optic form factors such as SFP (Small Form-factor Pluggable) or GBIC (Gigabit Interface Converter) modules. These modules can be safely inserted and removed while the chassis is powered and operating – this feature is also known as “hot-swappable”. When inserting or removing optics there are several precautions that should be taken. They include:

1. Ensuring that dust caps are mounted on SFP cages at all times unless a user is in the process of inserting or removing an SFP module. The dust caps will prevent the accumulation of residue or particles that may inhibit proper operation.
2. Ensuring that the user has properly discharged any possible electrostatic build-up and electrostatic discharges (ESD). This can be accomplished by properly user ‘grounding’ via an ESD wrist strap, or by touching earth or chassis ground before performing installation or removal of optics. ESD can damage or shorten the life of optical modules when not plugged into a chassis.
3. SFP and GBIC optical modules should always be stored in an ESD safe bag or other suitable ESD safe environment, free from moisture and stored at proper storage temperature (–40 to +85°C).
4. Disconnect all cables from SFP or GBIC module before insertion or removal of module.
5. Only RuggedCom Inc. certified optics should be used on RuggedCom products. Damage can occur to optics and product if compatibility and reliability have not been properly assessed.

4.9.1 Module Insertion – GBICs and SFPs

To insert GBICs or SFPs, special attention should be taken into the proper module orientation. Refer to Figure 25 for proper module orientation, as ports on the upper row of the product require optics to be inserted topside-up, and ports on the lower row of the product require modules to be inserted topside-down. GBICs should be inserted with module dust cover in place. SFPs should be inserted with dust cover in place, and the bail-latch in the locked position. Module should gently slide into port and should lock in place when module is fully inserted. To protect optics, dust covers should always be installed when cables are not connected.

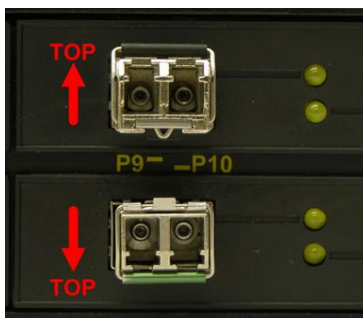

Figure 25: SFP Orientation for top row and bottom row ports

4.9.2 GBIC Module Removal

GBIC Modules have two locking latches on either side of the module shown in Figure 26. To remove GBIC module, disconnect any cable and replace with dust cover to protect the optics. User should depress both latches simultaneously and gently pull the module from the chassis. The module should be immediately stored in an ESD-safe environment.

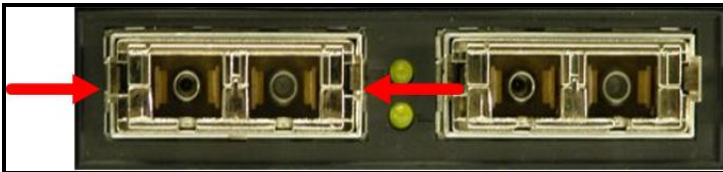

Figure 26: Locking latch location on GBIC optical modules

4.9.3 SFP Module Removal

SFP Modules are removed using the metal bail latch located on the top of the module shown in Figure 27. To remove the SFP module, disconnect any cable and replace with dust cover to protect the optics. User should grasp bail latch and gently pull outwards to unlock and remove the SFP module. Removal of the SFP module is shown further in Figure 28. The module should be immediately stored in an ESD-safe environment.



Figure 27: SFP Bail Latch location

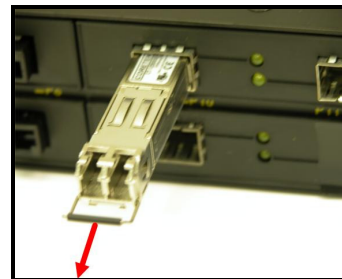

Figure 28: SFP Removal

5 Technical Specifications

5.1 Power Supply Specifications

Power Supply Type	Input Range		Fuse Rating	Max. Power Consumption ³	
	Min	Max		10/100TX FE Ports	Worst Case
12 – 24 VDC	10 VDC	36 VDC	6.3A(F) ²	15 W	30 W
24 VDC	18 VDC	36 VDC	5A(F) ²		
48 VDC	36 VDC	59 VDC	2A(T) ²		
HI (125/250 VDC) ¹	88 VDC	300 VDC	2A(T) ^{1,2}		
HI (110/230 VAC) ¹	85 VAC	265 VAC			

NOTES:

1. This is the same power supply for both AC and DC.
2. (F) Denotes fast-acting fuse, (T) denotes time-delay fuse
3. Power consumption varies based on configuration. 10/100Base-TX ports consume roughly 1W less than fiber optic ports
4. For continued protection against risk of fire, replace only with same type and rating of fuse.

5.2 Failsafe Relay Specifications

Parameter	Value (Resistive Load)
Max Switching Voltage	240VAC, 125VDC
Rated Switching Current	2A @ 240VAC 0.15A @ 125VDC, 2A @ 30VDC
Max Switching Capacity	150W, 500VA

5.3 Networking Standards Supported

Parameter	10 Mbps Ports	100 Mbps Ports	1000 Mbps Ports	Notes
IEEE 802.3	✓			10BaseT / 10BaseFL
IEEE 802.3u		✓		100BaseTX / 100BaseFX
IEEE 802.3z			✓	1000BaseSX/LX
IEEE 802.3ab			✓	1000BaseTx
IEEE 802.3x	✓	✓	✓	Full Duplex Operation
IEEE 802.1D	✓	✓	✓	MAC Bridges
IEEE 802.1Q	✓	✓	✓	VLAN (Virtual LAN)
IEEE 802.1p	✓	✓	✓	Priority Levels

5.4 Twisted-Pair Port Specifications

Parameter	Specification	Notes
Speed	10/100 Mbps	Auto-negotiating
Duplex	FDX / HDX	Auto-negotiating
Cable-Type	> Category 5	Shielded/Unshielded
Wiring Standard	TIA/EIA T568A/B	Auto-Crossover, Auto-polarity
Max Distance	100m	
Connector	RJ45	
Isolation	1.5kV	RMS 1-minute

5.5 Fiber Optical Specifications

The following sections detail fiber optical specifications on ports that can be ordered with the RSG2100 series Ethernet switch. The user determines the type of optics at time of ordering, and can determine the modules installed on a particular unit by reading the factory data file via the RuggedSwitch ROS™ user interface. The following sections detail specifications of fiber optic modules in two general categories, Ethernet / Fast Ethernet (10/100 Mbps) and Gigabit Ethernet (1000 Mbps).

5.5.1 Fast Ethernet (10/100 Mbps) Optical Specifications

The dual-port fast Ethernet optical specifications for RSG2100 ports 1-8 and 13-20 are shown below organized by module order code. Module order codes are contained within each product's factory data when assembled and configured at the factory. Consult the RuggedCom ROS to determine the optical assemblies installed in a particular product.

Optics Order Code	Speed Standard	Mode / Connector	Tx (nm)	Cable Type (um)	Tx min (dBm)	Tx max (dBm)	Rx Sensitivity (dBm)	Rx Saturation (dBm)	Typical Distance (km)	Power Budget (dB)
12-11-0011	10FL	MM/ST	820	62.5/125 50/125	-16 -19.8	-9 -12.8	-34 -34	-11.2 -11.2	2 2	18 14.2
12-11-0012	10FL	SM/ST	1310	9/125	-27	-14	-35	-3	5	8
12-11-0007	100FX	MM/ST	1300	62.5/125 50/125	-19 -22.5	-14 -14	-33.9 -33.9	-14 -14	2 2	14.9 11.4
12-11-0009	100FX	MM/SC	1300	50/125 62.5/125	-22.5 -19	-14 -14	-33.9 -33.9	-14 -14	2 2	11.4 14.9
12-11-0008	100FX	MM/MTRJ	1300	50/125 62.5/125	-22.5 -19	-14 -14	-33.5 -33.5	-14 -14	2 2	11 14.5
12-11-0046	100FX	MM/LC	1310	62.5/125	-19	-14	-32	-14	2	13
12-11-0006	100FX	SM/ST	1310	9/125	-15	-7	-34	-3	20	19
12-11-0005	100FX	SM/SC	1300	9/125	-15	-8	-31	-7	20	16
12-11-0004	100FX	SM/LC	1300	9/125	-15	-8	-38	-3	20	23
12-11-0031	100FX	SM/SC	1310	9/125	-5	0	-34	-3	50	29
12-11-0032	100FX	SM/LC	1310	9/125	-5	0	-35	-3	50	30
12-11-0033	100FX	SM/SC	1310	9/125	5	0	-37	0	90	42
12-11-0034	100FX	SM/LC	1310	9/125	0	5	-37	0	90	37

Table 7: Fast Ethernet optical specifications

5.5.2 Gigabit Ethernet (1000 Mbps) Optical Specifications

For maximum flexibility RuggedCom Inc. offers a number of different transceiver choices for Gigabit fiber optical communications. The table below details fiber optic specifications based on the 2-port modules or pluggable transceivers selected at time of ordering.

Optics Order Code	Speed Standard	Mode / Connector	Tx (nm)	Cable Type (um)	Tx min (dBm)	Tx max (dBm)	Rx Sensitivity (dBm)	Rx Saturation (dBm)	Typical Distance (km)	Power Budget (dB)
12-11-0036	1000SX	MM/LC	850	62.5/125	-9.5	-4	-20	0	0.4	10.5
		MM/LC	850	50/125	-9.5	-4	-20	0	0.7	10.5
12-11-0027	1000LX	SM/LC	1310	9/125	-9.5	-3	-21	-3	10	11.5
12-11-0028	1000LX	SM/LC	1310	9/125	-5	0	-24	-3	25	19
12-11-0025	1000LX	SM/SC	1310	9/125	-10	-3	-20	-3	10	10
12-11-0026	1000LX	SM/SC	1310	9/125	-5	0	-20	-3	25	15
25-10-0111	1000SX	MM/LC	850	62.5/125	-9	-2.5	-20	0	0.3	11
			850	50/125	-9	-2.5	-20	0	0.55	11
25-10-0100	1000LX	SM/LC	1310	9/125	-9.5	-3	-21	-3	10	11.5
25-10-0101	1000LX	SM/LC	1310	9/125	-3	2	-23	-3	25	20
25-10-0108 ⁵	1000LX	SM/LC	1550	9/125	-6	0	-23	-3	40	17
25-10-0109 ⁴	1000LX	SM/LC	1550	9/125	0	5	-23	-3	70	23
25-10-0202	1000BX	SM/SC	1310	SIMPLEX 9/125	-9	-3	-22	-3	10	13
25-10-0203 ⁴	1000BX	SM/SC	1490	SIMPLEX 9/125	-9	-3	-22	-3	10	13
25-10-0102	1000LX	SM/SC	1310	9/125	-9.5	-3	-21	-3	10	11.5
25-10-0103	1000LX	SM/SC	1310	9/125	-3	2	-23	-3	40	20
25-10-0113 ⁴	1000LX	SM/SC	1550	9/125	0	5	-23	-3	70	23

Table 8: Gigabit Ethernet optical specifications

Fiber Optic Notes:

1. Maximum segment length is greatly dependent on factors such as fiber quality, and number of patches and splices. Please consult RuggedCom sales associates when determining maximum segment distances.
2. All cabling is duplex type unless otherwise specified.
3. All optical power numbers are listed as dBm averages.
4. These transceivers utilize a distributed feedback (DFB) type laser and are rated for -20°C to +85°C operation only.
5. The 25-10-0108 SFP module is obsolete, and has been replaced with the 70 km 25-10-0109 SFP module.

5.6 Type Test Specifications

Electrical Safety	Levels	Comments
Dielectric Withstand	2 kV RMS for 1 minute	ANSI/IEEE C37.90 (1989) IEC 60255-5 (Section 6)
High Voltage Impulse	5 kV peak	IEC 60255-5 (Section 8)
Insulation Resistance	500 VDC for 1 minute	IEC 60255-5 (Section 6)

Electrical Environment	Levels	Comments
High Frequency Disturbance (Oscillatory)	2.5 kV @ 1 MHz for 2s	ANSI/IEEE C37.90.1 IEC 60255-22-1
IEC Surge	4 kV / 2 kV	IEC 61000-4-5 (Level 4)
IEC Fast Transient	2 kV / 1 kV	IEC 61000-4-4 (Level 4)
ANSI/IEEE Fast Transient	4 kV	ANSI/IEEE C37.90.1
IEC Radiated RFI Immunity	10 V/m	IEC 61000-4-3
ANSI/IEEE Radiated RFI Immunity	35 V/m	ANSI/IEEE C37.90.2
ESD (Electrostatic Discharge)	15 kV (air discharge) 8 kV (contact)	IEC 61000-4-2 (Level 4)

Atmospheric Environment	Levels	Comments
Temperature (Dry Cold)	-40°C	IEC 60068-2-1 Test Ad: 16 hrs @ -40°C
Temperature (Dry Heat)	85°C	IEC 60068-2-2 Test Bd: 16 hrs @ 85°C
Humidity	95% non-condensing	IEC 60068-2-30 Test Db: 6 cycles, 55°C, 95% Humidity

5.7 Operating Environment

Parameter	Range	Comments
Ambient Operating Temperature	-40 to 85°C	Ambient Temperature as measured from a 30cm radius surrounding the center of the RS1600 enclosure.
Ambient Relative Humidity	5% to 95%	Non-condensing
Ambient Storage Temperature	-40 to 85°C	

5.8 Mechanical Specifications

Parameter	Value	Comments
Dimensions	18.29 x 10.17 x 1.74 inches (464,57) x (258,32) x (44,20) mm	(Length x Width x Height) with mounting brackets installed
Weight	10 lb (4.5 Kg)	
Enclosure	18 AWG galvanized steel	

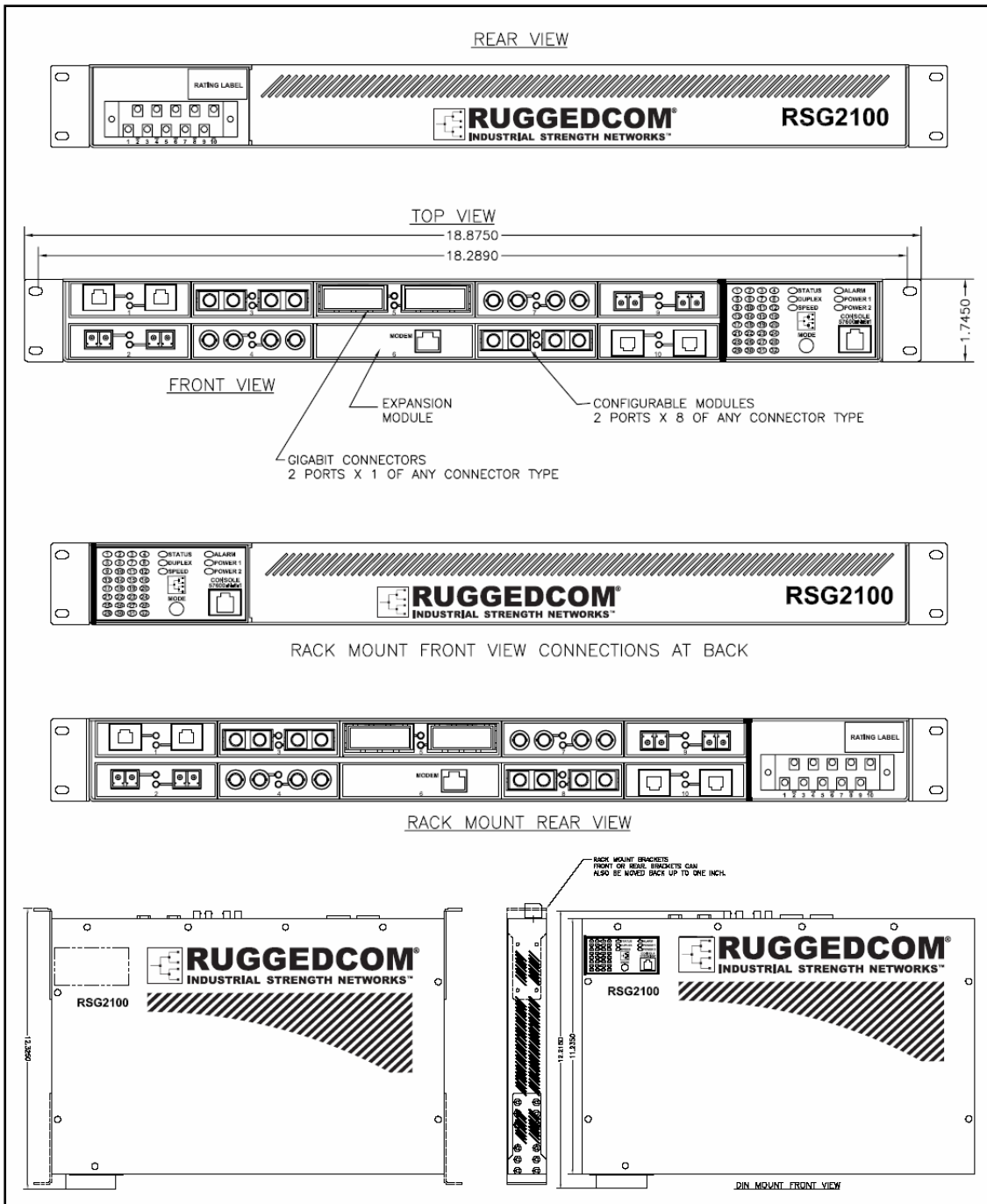

6 Agency Approvals

Agency	Standards	Comments
CSA	CSA C22.2 No. 60950, UL 60950	Approved
CE	EN 60950, EN 61000-6-2	Approved
FCC	FCC Part 15, Class A	Approved
CISPR	EN55022, Class A	Approved
FDA/CDRH	21 CFR Chapter 1, Subchapter J	Compliant
IEC/EN	EN60825-1:1994 + A11:1996 + A2:2001	Compliant

7 Warranty

RuggedCom warrants this product for a period of five (5) years from date of purchase. For warranty details, visit <http://www.ruggedcom.com/> or contact your customer service representative.

Should this product require warranty or service contact the factory at:

RuggedCom Inc.
30 Whitmore Road,
Woodbridge, Ontario
Canada L4L 7Z4
Phone: (905) 856-5288
Fax: (905) 856-1995