

HRT 3B

Diffuse reflection light scanner with background suppression

en 03-2011/04 50110702



Dimensioned drawing

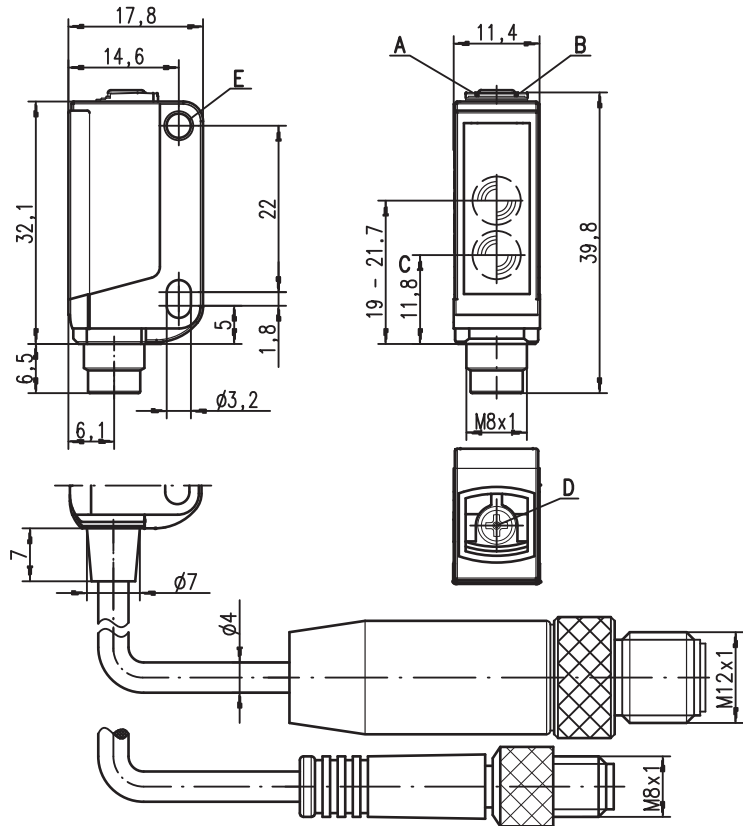

- A** Green indicator diode
- B** Yellow indicator diode
- C** Optical axis
- D** 8-turn potentiometer for scanning range adjustment
- E** Attachment sleeve



5 ... 600mm
250mm with
black-white error < 10%



- Diffuse reflection light scanner with infrared light and adjustable background suppression
- Exact scanning range adjustment through 8-turn potentiometer
- Very good black/white behavior and reliable switching nearly independent of the object or background properties
- Small and compact construction with robust plastic housing, protection class IP 67 for industrial application
- A²LS- Active Ambient Light Suppression
- Push-pull switching outputs
- High switching frequency for detection of fast events

Electrical connection

Plug connection, 4-pin

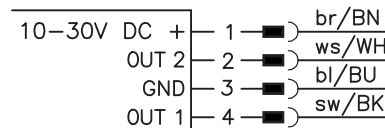

Cable, 4-wire

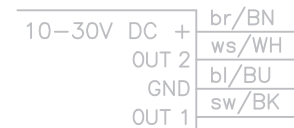

Plug connection, 3-pin

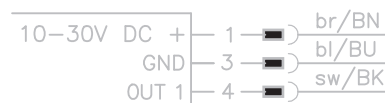

Accessories:

(available separately)

- Mounting systems (BT 3...)
- Cable with M8 or M12 connector (K-D ...)

We reserve the right to make changes • DS_HRT3B_en.fm

Specifications

Optical data

Typ. scanning range limit ¹⁾	5 ... 600mm
Scanning range ²⁾	see tables
Adjustment range ¹⁾	15 ... 600mm
Light beam characteristic	focussed at 200mm
Light source ³⁾	LED (modulated light)
Wavelength	880nm (infrared)

Timing

Switching frequency	1,000Hz
Response time	0.5ms
Delay before start-up	≤ 300ms (acc. to. IEC 60947-5-2)

Electrical data

Operating voltage U_B ⁴⁾	10 ... 30VDC (incl. residual ripple)
Residual ripple	≤ 15% of U_B
Open-circuit current	≤ 15mA
Switching output	.../66 ⁵⁾ 2 push-pull switching outputs pin 2: PNP dark switching, NPN light switching pin 4: PNP light switching, NPN dark switching
	.../6 ⁵⁾ 1 push-pull switching output pin 4: PNP light switching, NPN dark switching
	.../6D ⁵⁾ 1 push-pull switching output pin 4: PNP dark switching, NPN light switching
	.../44 2 PNP switching outputs, complementary
	.../4 1 NPN switching output light switching, pin 2: not connected ⁶⁾
	.../22 2 NPN switching outputs, complementary light/dark switching
Function characteristics	≥ ($U_B - 2V$) ≤ 2V
Signal voltage high/low	max. 100mA
Output current	adjustable via 8-turn potentiometer
Scanning range	

Indicators

Green LED	ready
Yellow LED	object detected - reflection

Mechanical data

Housing ⁷⁾	plastic (PC-ABS); 1 attachment sleeve, nickel-plated steel
Optics cover	plastic (PMMA)
Weight	with connector: 10g with 200mm cable and connector: 20g with 2m cable: 50g
Connection type	2m cable (cross section 4x0.20mm ²), connector M8 metal, 0.2m cable with connector M8 or M12

Environmental data

Ambient temp. (operation/storage)	-30°C ... +55°C / -30°C ... +70°C
Protective circuit ⁸⁾	2, 3
VDE safety class	III
Protection class	IP 67
Light source	free group (in accordance with EN 62471)
Standards applied	IEC 60947-5-2
Certifications	UL 508 ⁴⁾

- 1) Typ. scan. range limit/adjustment range: max. achievable scanning range/adjustment range for light objects (white 90%)
- 2) Scanning range: recommended scanning range for objects with different diffuse reflection
- 3) Average life expectancy 100,000h at an ambient temperature of 25°C
- 4) For UL applications: for use in class 2 circuits according to NEC only
- 5) The push-pull switching outputs must not be connected in parallel
- 6) Pin 2: unassigned, hence especially suitable for the connection to AS-interface I/O coupling modules
- 7) Patent Pending Publ. No. US 7,476,848 B2
- 8) 2=polarity reversal protection, 3=short-circuit protection for all transistor outputs

Remarks

Adapter plate:

BT 3.2 (part no. 50103844) for alternate mounting on 25.4 mm hole spacing (Omron E3Z, Sick W100...)

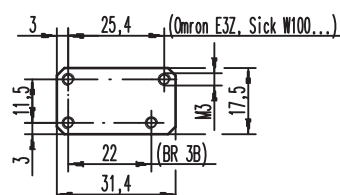

Tables

1	5	600
2	10	500
3	15	400

1	white 90%
2	grey 18%
3	black 6%

Scanning range [mm]

Diagrams

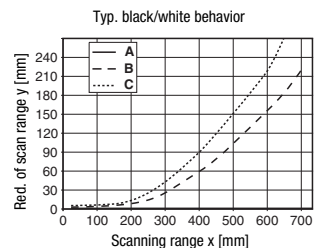
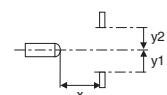
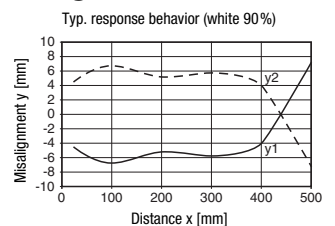

- A white 90%
- B grey 18%
- C black 6%

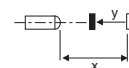

Remarks

Mounting system:















- ① = BT 3 (part no. 50060511)
- ②+③ = BT 3.1 ¹⁾ (part no. 50105585)
- ①+②+③ = BT 3B (part no. 50105546)

1)Packaging unit: PU = 10 pcs.

HRT 3B Diffuse reflection light scanner with background suppression

Order guide

Selection table		Order code →		HRT 3B/44 Part No. 50110659				
Equipment ↓								
Output 1 (OUT 1)	push-pull switching output		light switching	<input type="radio"/>				
			dark switching	<input type="radio"/>				
	PNP transistor output		light switching	<input type="radio"/>	•			
			dark switching	<input type="radio"/>				
	NPN transistor output		light switching	<input type="radio"/>				
			dark switching	<input type="radio"/>				
Output 2 (OUT 2)	push-pull switching output		light switching	<input type="radio"/>				
			dark switching	<input type="radio"/>				
	PNP transistor output		light switching	<input type="radio"/>	•			
			dark switching	<input type="radio"/>				
	NPN transistor output		light switching	<input type="radio"/>				
			dark switching	<input type="radio"/>				
Connection	cable 2,000mm		4-wire		•			
	cable 5,000mm		4-wire					
	M8 connector, metal		3-pin					
	M8 connector, metal		4-pin					
	M8 connector, metal, snap-on		4-pin					
	200mm cable with M8 connector		3-pin					
	200mm cable with M8 connector		4-pin					
	200mm cable with M12 connector		4-pin					
	pin 2: not assigned, suitable for connecting to AS-i coupling module							
Configuration	freely adjustable via 8-turn potentiometer				•			
	preset to scanning range [mm]:							
Switching frequency	200Hz							
	1,000Hz				•			

Application notes



- Approved purpose:**
 This product may only be used by qualified personnel and must only be used for the approved purpose. This sensor is not a safety sensor and is not to be used for the protection of persons..
- For glossy surfaces (e.g. metals), the light beam should not be incident on the object surface at a right angle. A slight inclination is sufficient for preventing undesired direct reflections. This may result in a reduction in the scanning range.
- Objects should only be moved in laterally from the right or left. Moving in objects from the connector side or operating side is to be avoided.
- Outside of the scanning range, the sensor operates as an energetic diffuse reflection light scanner. Light objects can still be reliably detected up to the scanning range limit.
- The sensors are equipped with effective measures for the maximum avoidance of mutual interference should they be mounted opposite one another. Opposite mounting of multiple sensors of the same type should, however, absolutely be avoided.

