

Part No. 501 10218



M8  
2.5 mm  
4 mm



10 - 30 V  
DC  
5 kHz  
non-embedded

- Slim and short cylindrical metal housing M8
- Stainless steel housing
- Built-in short circuit protection, inductive protection and polarity reversal protection
- LED for switching state visible from 360°

Dimensioned drawing

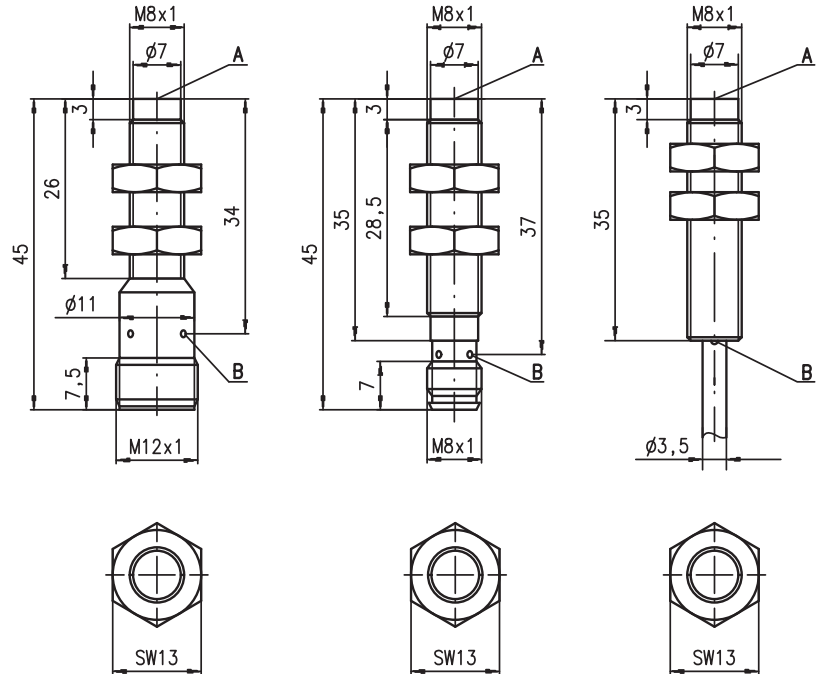

Tightening torque of the fastening nuts < 10Nm !

- A Active surface
- B Yellow indicator diode

Electrical connection

M8 connector

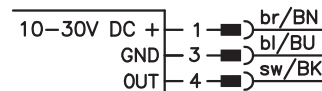

Cable

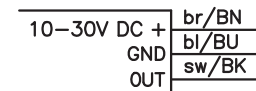

M12 connector

...NO... (normally open)

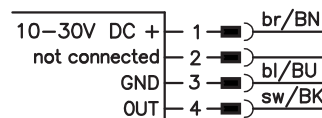

...NC... (normally closed)

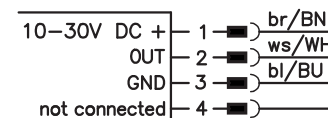

...NO...-S12 (normally open):  
...NC...-S12 (normally closed):

3-pin or 4-pin M12 connection cables can be used.  
only 4-pin M12 connection cables can be used.



Accessories:

(available separately)

- M8 connectors (D M8...)
- M12 connectors (KD ...)
- Ready-made cables (K-D ...)
- Mounting clamp (MC 008...)

We reserve the right to make changes • 208\_02gb.fm

## Specifications

### General specifications

Type of installation  
 Typ. operating range limit  $S_n$   
 Operating range  $S_a$

### IS 208...-2N5...

non-embedded installation  
 2.5mm  
 0 ... 2.0mm

### IS 208...-4N0...

4.0mm  
 0 ... 3.2mm

### Electrical data

Operating voltage  $U_B$  1)  
 Residual ripple  $\sigma$   
 Output current  $I_L$   
 Open-circuit current  $I_0$   
 Residual current  $I_r$   
 Switching output/function

10 ... 30VDC  
 $\leq 20\%$  of  $U_B$   
 $\leq 200$ mA  
 $\leq 10$ mA  
 $\leq 100\mu$ A  
 .../4NO... PNP transistor, make-contact (NO)  
 .../4NC... PNP transistor, break-contact (NC)  
 .../2NO... NPN transistor, make-contact (NO)  
 .../2NC... NPN transistor, break-contact (NC)

Voltage drop  $U_d$   
 Hysteresis H of  $S_r$   
 Temperature drift of  $S_r$   
 Repeatability

$\leq 2$ V  
 $\leq 5\%$   
 $\leq 10\%$  2)  
 $\leq 4.8\%$  3)

### Timing

Switching frequency f  
 Delay before start-up

5kHz  
 $\leq 10$ ms  
 3.5kHz

### Indicators

Yellow LED (visible from 360°)

switching state

### Mechanical data

Housing  
 Standard surface plate  
 Active surface  
 Weight (M8 plug/cable)  
 Connection type

stainless steel  
 8 x 8mm<sup>2</sup>, Fe360  
 PBTP  
 approx. 12g/approx. 70g  
 M8 connector, 3-pin, or  
 M12 connector, 4-pin, or  
 cable: 2m, PVC, 3 x 0.14mm<sup>2</sup>,  $\varnothing$  3.5mm  
 12 x 12mm<sup>2</sup>, Fe360

### Environmental data

Ambient temperature  
 Protection class  
 Protective circuit 4)  
 Standards applied  
 Electromagnetic compatibility

-25°C ... +70°C  
 IP 67  
 1, 2, 3  
 IEC/EN 60947-5-2  
 IEC 60255-5  
 IEC 61000-4-2  
 IEC 61000-4-3  
 IEC 61000-4-4  
 1 kV  
 Level 3 air 8kV (ESD)  
 Level 3 10V/m (RFI)  
 Level 3 2kV (Burst)

- 1) Observe the safety regulations and installation instructions regarding power supply and wiring; for UL applications: only for use in "Class 2" circuits acc. to NEC
- 2) Over the entire operating temperature range
- 3) For  $U_B = 20 \dots 30$ VDC, ambient temperature  $T_a = 23^\circ\text{C} \pm 5^\circ\text{C}$
- 4) 1=polarity reversal protection, 2=short circuit protection, 3=inductive protection for all outputs

## Order guide

The sensors listed here are preferred types; current information at [www.leuze.com](http://www.leuze.com).

	Designation	Part No.
$S_n = 2.5$ mm	IS 208 MM/4NO-2N5	501 09645
	IS 208 MM/4NO-2N5-S8.3	501 09646
	IS 208 MM/4NO-2N5-S12	501 09647
$S_n = 4$ mm	IS 208 MM/4NO-4N0	501 09658
	IS 208 MM/4NO-4N0-S8.3	501 09659
	IS 208 MM/2NO-4N0	501 09661
	IS 208 MM/2NO-4N0-S8.3	501 09662

## Tables

### Reduction factors:

for $S_n = 2.5$ mm		for $S_n = 4.0$ mm	
Steel Fe360	1	Steel Fe360	1
Copper	0.20	Copper	0.42
Aluminum	0.25	Aluminum	0.45
Brass	0.35	Brass	0.52
Stainless steel	0.70	Stainless steel	0.74

## Mounting

### Non-embedded installation:

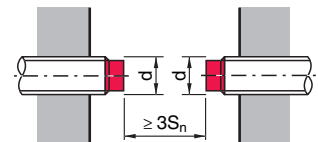
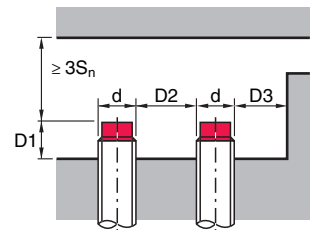

Ferromagnetic and non-ferromagnetic materials			
$S_n$ [mm]	D1 [mm]	D2 [mm]	D3 [mm]
2.5	8.0	10.0	4.0
4.0	6.0	14.0	6.0

## Diagrams

### Models with $s_n = 2.5$ mm

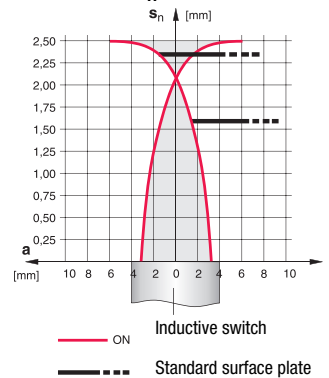

### Models with $S_n = 4.0$ mm

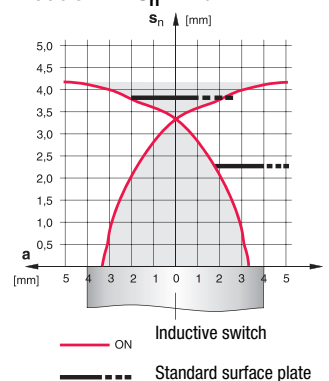

**Type key**

I	S	2	0	8	M	M	/	4	N	0	-	2	N	5	-	S	8	.	3
---	---	---	---	---	---	---	---	---	---	---	---	---	---	---	---	---	---	---	---

**Operating principle / construction**

**IS** Inductive switch / Standard

**Series**

**208** series with M8 x 1 external thread

**Housing / thread**

**MM** metal housing (active surface: plastic) / metric thread

**Output function**

**4NO** PNP transistor, make-contact (NO)

**4NC** PNP transistor, break-contact (NC)

**2NO** NPN transistor, make-contact (NO)

**2NC** NPN transistor, break-contact (NC)

**Measurement range / type of installation**

**2N5** typ. scan range limit 2.5 mm / non-embedded installation

**4N0** typ. scan range limit 4.0 mm / non-embedded installation

**Electrical connection**

**N/A** cable, PVC, standard length 2000 mm

**S8.3** M8 connector, 3-pin, axial

**S12** M12 connector, 4-pin, axial

**200-S8.3** cable, PVC, length 200 mm with M8 connector, 3-pin, axial

**Remarks**

- **Approved purpose:**  
Inductive switches are electronic sensors used for the inductive, contactless detection of objects.

