

SLSR 46B

Protective throughbeam photoelectric sensor

en 04-2013/02 50110389-01



0.5 ... 44m



- Protective throughbeam photoelectric sensor with visible red light, up to category 2 in accordance with ISO 13849-1
- Small and compact construction with robust plastic housing, protection class IP 67/IP 69K for industrial application
- Fast alignment through *brightVision*[®]
- LED display featuring excellent visibility for alignment control
- Push-pull switching outputs

Dimensioned drawing

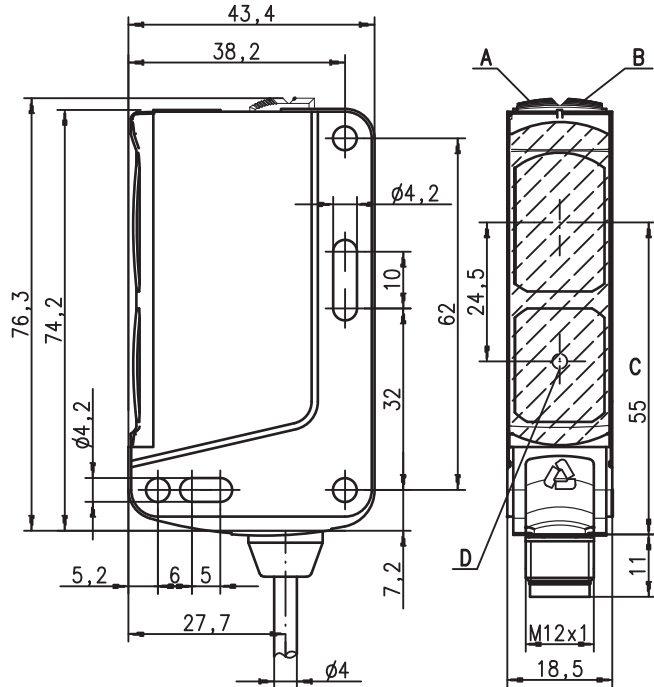

- A Green indicator diode
- B Yellow indicator diode
- C Optical axis
- D Alignment control indicator diode (only at receiver)

Electrical connection

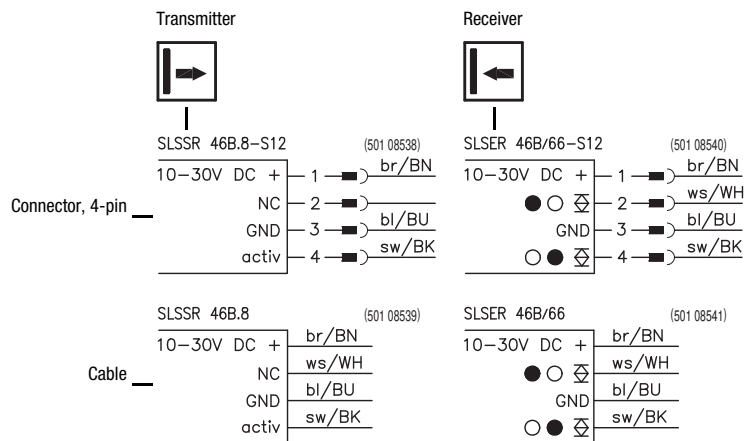

Accessories:

(available separately)

- Mounting systems (BT 46.1, BT 46.1.5, BT 46.2)
- M12 connectors (KD ...)
- Ready-made cables (K-D ...)
- Test monitoring units MSI-TR1 (Part No. 549988)
- Sensorscope SAT 5 (alignment control, Part No. 50109545)

We reserve the right to make changes • DS_SLSR_46B_en_50110389-01.fm



Specifications

Safety-relevant data

Type in accordance with IEC/EN 61496	type 2
Performance Level (PL) in accordance with ISO 13849-1 ¹⁾	PL d
Category in accordance with ISO 13849 ¹⁾	cat. 2
Mean time to dangerous failure (MTTFd)	407 years
Service life (TM)	20 years

Optical data

Typ. operating range limit ²⁾	0.5 ... 44 m
Operating range ³⁾	0.5 ... 40 m
Light source ⁴⁾	LED (modulated light)
Wavelength	624 nm (visible red light)

Timing

Switching frequency	100Hz
Response time	5ms
Delay before start-up	≤ 100 ms

Electrical data

Operating voltage U_B ⁵⁾	10 ... 30VDC (incl. residual ripple)
Residual ripple	≤ 15% of U_B
Open-circuit current	≤ 15mA per transmitter/receiver, ≤ 30mA per pair
Switching output/function ⁶⁾	2 push-pull switching outputs pin 2: PNP dark switching, NPN light switching pin 4: PNP light switching, NPN dark switching
Signal voltage high/low	≥ ($U_B - 2V$) / ≤ 2V
Output current	max. 100mA

Indicators

Transmitter	
Green LED	ready
Yellow LED	transmitter active
Receiver	
Green LED	ready
Yellow LED	light path free
Yellow LED, flashing	light path free, no performance reserve
Yellow LED, front	alignment indicator ⁷⁾

Mechanical data

Housing	plastic (PC-ABS)
Optics cover	plastic (PMMA)
Weight (plug/cable)	100g/200g per pair
Connection type	M12 connector (4-pin) or cable, length 2m (cross section 4x0.21 mm ²)

Environmental data

Ambient temp. (operation/storage)	-30 °C ... +55 °C / -30 °C ... +60 °C
Protective circuit ⁸⁾	2, 3
VDE safety class ⁹⁾	II, all-insulated
Protection class	IP 67, IP 69K
LED class	1 (acc. to EN 60825-1)
Standards applied	IEC 60947-5-2

Activation input active

Transmitter active/not active	≥ 8V / ≤ 2V
Activation/disable delay	≤ 1 ms / ≤ 2 ms
Input resistance	10KΩ ± 10%

- 1) In combination with a suitable test monitoring unit, e.g. MSI-TR1
- 2) Typ. operating range limit: max. attainable range without performance reserve
- 3) Operating range: recommended range with performance reserve
- 4) Average life expectancy 100,000h at an ambient temperature of 25 °C
- 5) For UL applications: for use in class 2 circuits only
- 6) The push-pull switching outputs must not be connected in parallel
- 7) LED display featuring excellent visibility for alignment control
- 8) 2=polarity reversal protection, 3=short-circuit protection for all transistor outputs
- 9) Rating voltage 50V

Order guide ¹⁾

	Designation	Part No.
With M12 connector		
Transmitter and receiver	SLSR 46B/66.8-S12	
Transmitter	SLSSR 46B.8-S12	50108538
Receiver	SLSER 46B/66-S12	50108540
Cable, cable length 2m		
Transmitter and receiver	SLSR 46B/66.8	
Transmitter	SLSSR 46B.8	50108539
Receiver	SLSER 46B/66	50108541

1) Version 2010 A-Z

Tables

0.5	40	44
-----	----	----

	Operating range [m]
	Typ. operating range limit [m]

Safety notices

Before using the safety sensor, a risk evaluation must be performed according to valid standards. For mounting, operation and tests, this document as well as all applicable national and international standards and regulations must be observed, printed out and handed to the affected personnel.

Before working with the safety sensor, completely read and observe the documents applicable to your task.

In particular, the following national and international legal regulations apply for the commissioning, technical inspections and work with safety sensors:

- Machinery directive 2006/42/EC
- Use of Work Equipment Directive 89/655/EEC supplemented by Directive 95/63 EC
- Accident-prevention regulations and safety rules
- Other relevant standards
- Standards, e.g. ISO 13855

Symbols



Attention!

Warning sign – This symbol indicates possible dangers. Please pay especially close attention to these instructions!



This symbol identifies the transmitter.



This symbol identifies the receiver.

Safety sensor area of application

The protective throughbeam photoelectric sensor is an active optoelectronic protective device only in connection with a safety-relevant control system, in which the cyclical testing of transmitter and receiver is carried out in accordance with EN 61496-1, up to category 2 and PL d in accordance with EN ISO 13849-1.



Attention!

- The safety sensor protects persons at access points or at points of operation of machines and plants.
- The safety sensor only detects persons upon entry to the danger area; it does not detect persons who are located within the danger area. For this reason, a start-up/restart interlock is mandatory.
- No protective function without adequate safety distance.
- The power supply unit used to operate the photoelectric sensor has to be able to compensate for changes and interruptions of the supply voltage acc. to EN 61496-1.
- Also observe the safety notices in the documentation of the connected test device!
- Additional measures must be taken to ensure that the AOPD does not experience a dangerous failure due to glare from other light sources.

Proper use

The safety sensor must only be used after it has been selected in accordance with the respectively valid instructions and relevant standards, rules and regulations regarding occupational safety and safety at work, and after it has been installed on the machine, connected, commissioned, and checked by a competent person.

Foreseeable misuse

Any use other than that defined under the "Proper use" or which goes beyond that use is considered improper use. The user must ensure that no optical influence on the AOPD occurs through other forms of light beams, e.g. through

- wireless control devices on cranes,
- radiation from welding sparks,
- stroboscopic lights.

Competent personnel

Prerequisites for competent personnel:

- He has a suitable technical education.
- He knows the instructions for the safety sensor and the machine.
- He has been instructed by the responsible person on the mounting and operation of the machine and of the safety sensor.

Responsibility for safety

Manufacturer and operator must ensure that the machine and implemented safety sensor function properly and that all affected persons are adequately informed and trained.

The **manufacturer** of the machine is responsible for:

- Safe implementation of the safety sensor.
- Imparting all relevant information to the operator.
- Adhering to all regulations and directives for the safe commissioning of the machine.

The **operator** of the machine is responsible for:

- Instructing the operating personnel.
- Maintaining the safe operation of the machine.
- Adhering to all regulations and directives for occupational safety and safety at work.
- Regular testing by competent personnel.

Safety distances



Attention!

The protective throughbeam photoelectric sensor must be installed with the correctly calculated safety distance as well as suitable beam distances from a potentially dangerous motion: if an interruption of the light beam occurs, the danger area may only be reached once the machine has already come to a dead stop.

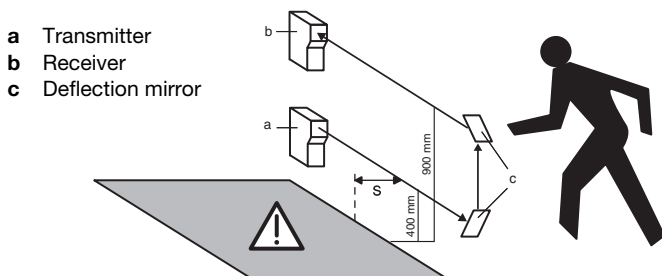

Number of beams	Heights above reference plane, e.g. floor [mm]	Additional distance C [mm]
1	750	1200
2	400, 900	850
3	300, 700, 1100	850
4	300, 600, 900, 1200	850

The safety distance **S** between photoelectric sensor and danger area is calculated using the following formula (ISO 13855):

$$S = (K \cdot T) + C$$

S: Safety distance [mm] between photoelectric sensor and danger area.

K: Approach speed (constant = 1600 mm/s).

T: Time delay [s] between interruption of the light beam and stand-still of the machine.

C: Safety constant (additional distance) = 850mm or 1200mm, see table above.

Multi-axle installation

With multi-axle installation the light beams have to run parallel to the reference plane (e.g. floor) and must be aligned mutually parallel.

For this the beam direction must be set oppositely in each case. Otherwise the light beams could cause mutual interference and disturb proper functioning.

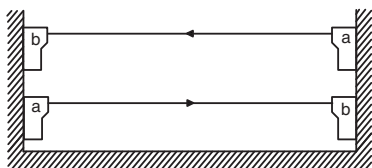

- a Transmitter
- b Receiver

Distance to reflecting surfaces

When mounting, a sufficiently large distance from the optical axis to reflecting surfaces must be selected.

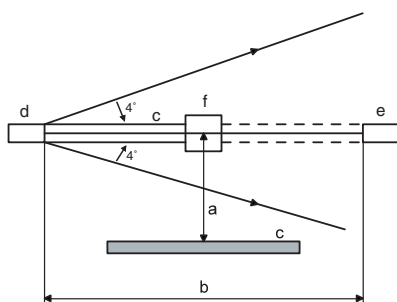

- a Distance to the reflecting surface
- b Protected field width
- c Reflecting surface
- d Transmitter
- e Receiver
- f Object

Commissioning

Alignment of the sensors

- Mount photoelectric sensors with corresponding fixing brackets from Leuze electronic.
- Apply operating voltage to transmitter and receiver and activate transmitter via activation input (see "Electrical connection").
- Yellow and green LEDs on transmitter illuminate.
- Position receiver until the yellow LED illuminates.

Receiver LED blinks yellow: Light path free, but no performance reserve; clean and readjust photoelectric sensor, or check operating conditions.

Safety notices for test function

1. To perform testing correctly the activation input of the SLSR 46B transmitter must be connected to a test monitoring unit.
2. The test duration during access protection must not exceed 150ms.
3. Subsequent to sensor activation the output switching elements of the test monitoring unit must remain in the 'off' state for at least 80ms so that the downstream equipment can be switched off safely when the photoelectric sensor is used for access protection.
4. In order to comply with points 2 and 3, the use of Leuze electronic test monitoring units (MSI-TR1) is recommended.

Check

The checks should ensure that the Optoelectronic Protective Devices have been used acc. to the national/international regulations, in particular in accordance with the machine and work-equipment directive.

Check before initial commissioning

- Observe the nationally and internationally valid regulations.
- Is the required safety distance (protective field of the safety sensor to the next point of operation) maintained?
- Is the safety sensor effective during the entire dangerous movement and in all adjustable operating modes of the machine?
- It must not be possible to climb over, climb under or circumvent the light path.
- Ensure that the sensor only detects persons upon entry to the danger area and does not detect whether persons are located within the danger area.
- Is a start-up/restart interlock present?
- Before they begin work, have a competent person train the operating personnel in their respective tasks.

Regular testing by competent personnel

The reliable interaction of safety sensor and machine must be periodically tested in order to detect changes to the machine or impermissible tampering with the safety sensor.

- Have all tests performed by competent personnel.
- Observe the nationally and internationally applicable regulations and the time periods specified therein.

Daily check of the effectiveness of the safety sensor

It is extremely important to examine the effectiveness of the protective field daily so that it is ensured that e.g. even with adjustments to e.g. parameters, the protective function is active at all points.

Interrupt the light beam between the transmitter and receiver (test rod Ø 22mm)

- in front of the transmitter.
- in the middle between the transmitter and receiver.
- in front of and behind the deflection mirror.

It must not be possible to initiate the dangerous state during beam interruption.

Disposal

For disposal observe the applicable national regulations regarding electronic components.



the **sensor** people

**EG-KONFORMITÄTS-
ERKLÄRUNG**

**EC DECLARATION OF
CONFORMITY**

**DECLARATION CE DE
CONFORMITE**

Der Hersteller	The Manufacturer	Le constructeur
	Leuze electronic GmbH + Co. KG In der Braike 1, PO Box 1111 73277 Owen, Germany	
erklärt, dass die nachfolgend aufgeführten Produkte den einschlägigen Anforderungen der genannten EG-Richtlinien und Normen entsprechen.	declares that the following listed products fulfil the relevant provisions of the mentioned EC Directives and standards.	déclare que les produits identifiés suivants sont conformes aux directives CE et normes mentionnées.
Produktbeschreibung:	Description of product:	Description de produit:
Einweg-Sicherheits-Lichtschanke, Berührungslos wirkende Schutzeinrichtung, Sicherheitsbauteil nach 2006/42/EG Anhang IV SLSR 46B Seriennummer siehe Typschild	Protective throughbeam photoelectric sensor, Active opto-electronic protective device, safety component in acc. with 2006/42/EC annex IV SLSR 46B Part No. see name plates	Barrière unidirectionnelle, Équipement de protection électrosensible, Élément de sécurité selon 2006/42/CE annexe IV SLSR 46B Art. n° voir plaques signalétiques
Angewandte EG-Richtlinie(n):	Applied EC Directive(s):	Directive(s) CE appliquées:
2006/42/EG 2004/108/EG 2006/95/EG	2006/42/EC 2004/108/EC 2006/95/EC	2006/42/CE 2004/108/CE 2006/95/CE
Angewandte Normen:	Applied standards:	Normes appliquées:
EN 61496-1:2004; IEC 61496-2:2006; EN ISO 13849-1:2009; EN 50178:1997		
Benannte Stelle / Baumusterprüfbescheinigung:	Notified Body / Certificate of Type Examination:	Organisme notifié / Attestation d'examen CE de type:
TÜV-SÜD PRODUCT SERVICE GmbH Zertifizierungsstelle Ridlerstraße 65 D-80339 München	/	Z10090368636001
Bevollmächtigter für die Zusammenstellung der technischen Unterlagen:	Authorized person to compile the technical file:	Personne autorisée à constituer le dossier technique:
Robert Sammer; Leuze electronic GmbH + Co. KG Liebigstr. 4; 82256 Fuerstenfeldbruck; Germany		

Owen, 15.6.10
Datum / Date / Date

[Signature]
Dr. Harald Gröbel, Geschäftsführer / Director / Directeur

Leuze electronic GmbH + Co. KG
In der Braike 1
D-73277 Owen
Telefon +49 (0) 7021 573-0
Telefax +49 (0) 7021 573-199
info@leuze.de
www.leuze.de

Leuze electronic GmbH + Co. KG, Sitz Owen, Registergericht Stuttgart, HRA 230712
Persönlich haftende Gesellschafterin Leuze electronic Geschäftsführungs-GmbH,
Sitz Owen, Registergericht Stuttgart, HRB 230550
Geschäftsführer: Dr. Harald Gröbel (Vorsitzender), Karsten Just
USt-IdNr. DE 145912521 | Zofnummer 254232
Es gelten ausschließlich unsere aktuellen Verkaufs- und Lieferbedingungen
Only our current Terms and Conditions of Sale and Delivery shall apply

Nr. 60090-201004

LEO-ZQM-149-01-FO