



PRK 96

Retro-reflective photoelectric sensors with polarisation filter



10m
18m



- Polarised retro-reflective photoelectric sensor with large operating range in visible red light
- Robust metal housing with glass cover or plastic housing, protection class IP 67/ IP 69K for industrial application
- Complementary outputs, sensitivity adjustment and delay before start-up for optimal adaptation to the application
- Connection via M12 connector or terminal compartment
- Multiple options with warning output, activation input, switching delays and optics heating for use at low temperatures

Dimensioned drawing

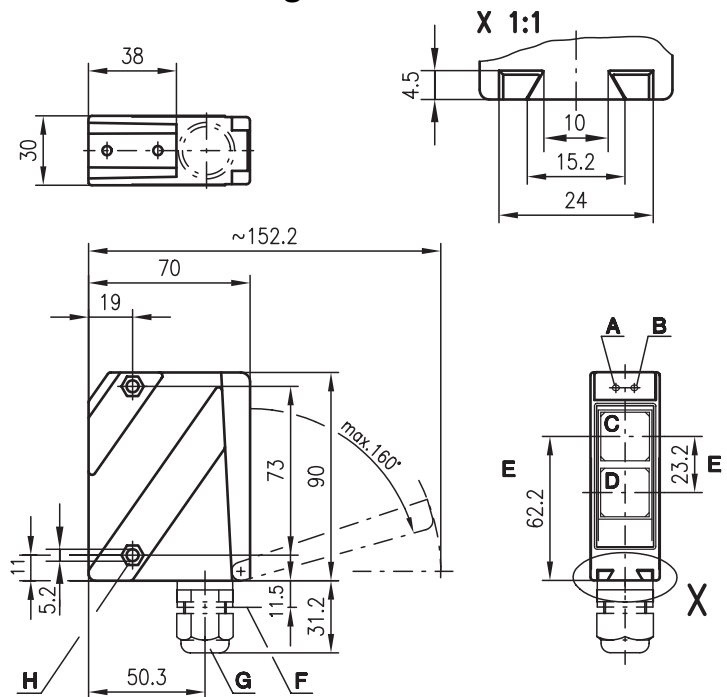

- A Indicator diode green
- B Indicator diode yellow
- C Receiver
- D Transmitter
- E Optical axis
- F Device plug M12x1
- G Screwed cable gland M16x1.5 for Ø 5 ... 10mm
- H Countersinking for SK nut M5, 4.2 deep
- I Connection terminals
- K Cable entry
- L Sensitivity adjustment

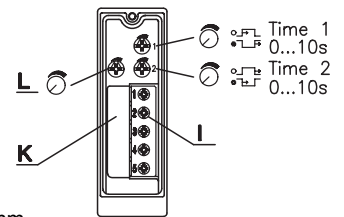

Electrical connection

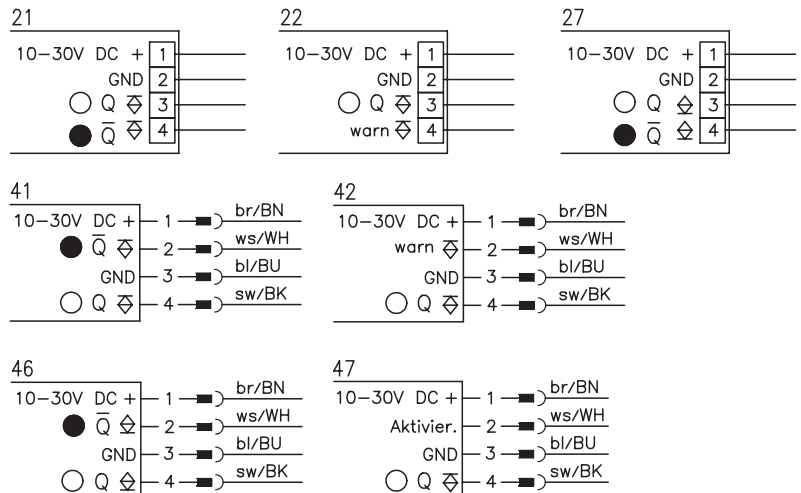

Accessories:

(available separately)

- Mounting systems (BT 96, BT 96.1, UMS 96, BT 450.1-96)
- M12 connectors (KD ...)
- Ready-made cables (K-D ...)
- Reflectors
- Reflective tapes

We reserve the right to make changes • 96_b03e.fm



Specifications

Optical data

Typ. operating range limit (TK(S) 100x100) ¹⁾	10m/18m
Operating range ²⁾	see tables
Light spot diameter	approx. 130mm at 6m
Light source	LED (modulated light)
Wavelength	660nm (visible red light, polarised)

Timing

Switching frequency	1000Hz
Response time	0.5ms
Delay before start-up	≤ 200ms

Electrical data

Operating voltage U_B	10 ... 30VDC (incl. residual ripple)
Residual ripple	≤ 15% of U_B
Bias current	≤ 40mA, ≤ 75mA with optics heating
Switching output	PNP or NPN transistor
Function characteristics	light/dark switching
Signal voltage high/low	≥ ($U_B - 2V$) / ≤ 2V
Output current	max. 100mA
Sensitivity	adjustable

Indicators

LED green	ready
LED yellow	light path free
LED yellow flashing	light path free, no performance reserve

Mechanical data

Housing	diecast zinc
Optics cover	glass
Weight	380g
Connection type	terminals or M12 connector

Environmental data

Ambient temp. (operation/storage)	-20°C ... +55°C / -40°C ... +55°C
Protective circuit ³⁾	1, 2, 3, 4
VDE safety class ⁴⁾	II, all-insulated
Protection class	IP 67, IP 69K ⁵⁾
LED class	1 (acc. to EN 60825-1)
Standards applied	IEC 60947-5-2

Options

Warning output autoControl warn	PNP transistor, 100mA, counting principle
Optics heating	for temperature changes, prevents fogging
Low temperature	to -35°C
Switching delay (slow oper./release)	0 ... 10s (separately adjustable)

- 1) Typ. operating range limit: max. attainable range without performance reserve
- 2) Operating range: recommended range with performance reserve
- 3) 1=transient protection, 2=polarity reversal protection, 3=short circuit protection for all outputs, 4=interference blanking
- 4) Rating voltage 250VAC
- 5) IP 69K test acc. to DIN 40050 part 9 simulated, high pressure cleaning conditions without the use of additives, acids and bases are not part of the test

Order guide

Selection table		Order code →							
Equipment ↓		PRK 96M/P-1370-22 Part No. 500 25182	PRK 96M/P-1370-42 Part No. 500 25186	PRK 96M/P-1400-22 Part No. 500 25178	PRK 96M/P-1400-42 Part No. 500 31549	PRK 96M/P-3360-21 Part No. 500 82065	PRK 96M/N-3366-27 Part No. 501 02379	PRK 96M/P-3380-41 Part No. 500 61452	PRK 96M/P-1361.1-47 Part No. 501 04279
Housing	metal	●	●	●	●	●	●	●	●
	plastic								
Light source	red light (8m)	●	●	●	●				●
	red light (15m)					●	●	●	
Connection	terminals	●		●		●	●		
	M12 connector		●		●			●	●
Features	optics heating/low temp.			●	●		●		
	switching delay			●	●			●	
	warning output	●	●	●	●				
	activation input								●
	NPN switching output						●		
	Light/dark switching								●

Tables

10m models

Reflectors	Operating range
1 TK(S) 100x100	0.3 ... 8m
2 MTK(S) 50x50	0.3 ... 7m
3 TK(S) 30x50	0.3 ... 4.5m
4 TK(S) 20x40	0.3 ... 3m
5 TK(S) 82	0.3 ... 6m
6 Tape 2 100x100	0.3 ... 4m

1	0.1	8	10
2	0.1	7	8.5
3	0.1	4.5	5
4	0.1	3	4
5	0.1	6	7.5
6	0.1	4	5.5

18m models

Reflectors	Operating range
1 TK(S) 100x100	0.3 ... 15m
2 MTK(S) 50x50	0.3 ... 11m
3 TK(S) 30x50	0.3 ... 6m
4 TK(S) 20x40	0.3 ... 5m
5 TK(S) 82	0.3 ... 11m
6 Tape 2 100x100	0.3 ... 6m

1	0.1	15	18
2	0.1	11	12
3	0.1	6	7.5
4	0.1	5	6
5	0.1	11	11.5
6	0.1	6	7.5

□ Operating range [m]
 ▒ Typ. operating range limit [m]

Diagrams

10m models

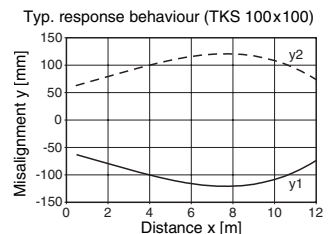

18m models

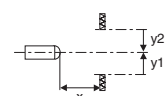
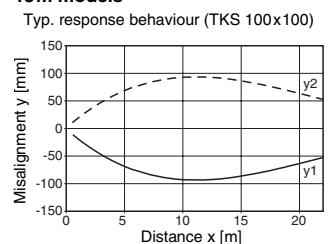

Remarks

- The polarised retro-reflective photoelectric sensor is also available with an integrated AS-i chip for direct connection to the AS-i system.