

**MLC 320**  
Safety light curtains



© 2013

Leuze electronic GmbH + Co. KG

In der Braike 1

D-73277 Owen/Germany

Phone: +49 7021 573-0

Fax: +49 7021 573-199

<http://www.leuze.com>

[info@leuze.de](mailto:info@leuze.de)

<b>1</b>	<b>About this document</b> .....	<b>5</b>
1.1	Used symbols and signal words .....	5
1.2	Checklists .....	6
<b>2</b>	<b>Safety</b> .....	<b>7</b>
2.1	Approved purpose and foreseeable improper operation .....	7
2.1.1	Proper use .....	8
2.1.2	Foreseeable misuse .....	8
2.2	Competent persons .....	8
2.3	Responsibility for safety .....	8
2.4	Disclaimer .....	9
<b>3</b>	<b>Device description</b> .....	<b>10</b>
3.1	Device overview .....	10
3.2	Connection technology .....	11
3.3	Display elements .....	11
3.3.1	Operating indicators on the MLC 300 transmitter .....	11
3.3.2	Operating indicators on the MLC 320 receiver .....	12
3.3.3	Alignment display .....	14
<b>4</b>	<b>Functions</b> .....	<b>15</b>
4.1	Start/restart interlock RES .....	15
4.2	EDM contactor monitoring .....	15
4.3	Transmission channel changeover .....	16
4.4	Range reduction .....	16
<b>5</b>	<b>Applications</b> .....	<b>17</b>
5.1	Point of operation guarding .....	17
5.2	Access guarding .....	17
5.3	Danger zone guarding .....	18
<b>6</b>	<b>Mounting</b> .....	<b>19</b>
6.1	Arrangement of transmitter and receiver .....	19
6.1.1	Calculation of safety distance S .....	19
6.1.2	Calculation of safety distance $S_{RT}$ or $S_{RO}$ if protective fields act orthogonally to the approach direction .....	20
6.1.3	Calculation of safety distance S for parallel approach to the protective field .....	24
6.1.4	Minimum distance to reflective surfaces .....	25
6.1.5	Preventing mutual interference between adjacent devices .....	26
6.2	Mounting the safety sensor .....	27
6.2.1	Suitable mounting locations .....	27
6.2.2	Definition of directions of movement .....	28
6.2.3	Fastening via BT-NC60 sliding blocks .....	28
6.2.4	Fastening with BT-R swivel mount .....	29
6.2.5	One-sided mounting on the machine table .....	29
6.3	Mounting accessories .....	30
6.3.1	Deflecting Mirror for multiple-side guarding .....	30
6.3.2	MLC-PS protective screen .....	31
<b>7</b>	<b>Electrical connection</b> .....	<b>33</b>
7.1	Pin assignment transmitter and receiver .....	33
7.1.1	MLC 300 transmitter .....	33
7.1.2	MLC 320 receiver .....	34
7.2	Circuit diagram examples .....	36

7.2.1	MLC 320 circuit diagram example . . . . .	36
<b>8</b>	<b>Starting up the device. . . . .</b>	<b>37</b>
8.1	Switching on . . . . .	37
8.2	Aligning the sensor . . . . .	37
8.3	Aligning of Deflecting Mirrors with the laser alignment aid . . . . .	38
8.4	Unlocking start/restart interlock . . . . .	38
<b>9</b>	<b>Testing . . . . .</b>	<b>40</b>
9.1	Before the initial start-up and following modifications . . . . .	40
9.1.1	Checklist - to be performed prior to the initial start-up and following modifications . . . . .	40
9.2	To be performed periodically by competent persons. . . . .	42
9.3	Daily or at change of shift by the operator . . . . .	42
9.3.1	Check list – daily or at change of shift . . . . .	42
<b>10</b>	<b>Maintenance. . . . .</b>	<b>44</b>
<b>11</b>	<b>Rectifying the fault . . . . .</b>	<b>45</b>
11.1	What to do in case of failure? . . . . .	45
11.2	Operating displays of the LEDs . . . . .	45
11.3	Error messages 7-segment display . . . . .	47
<b>12</b>	<b>Disposing . . . . .</b>	<b>49</b>
<b>13</b>	<b>Service and support . . . . .</b>	<b>50</b>
<b>14</b>	<b>Technical data . . . . .</b>	<b>51</b>
14.1	General specifications . . . . .	51
14.2	Dimensions, weight, response time . . . . .	53
14.3	Dimensional drawings: accessories. . . . .	55
<b>15</b>	<b>Ordering information and accessories . . . . .</b>	<b>57</b>
<b>16</b>	<b>EC Declaration of Conformity. . . . .</b>	<b>62</b>

# 1 About this document

## 1.1 Used symbols and signal words

Table 1.1: Warning symbols and signal words

	Symbol indicating dangers to persons
NOTICE	Signal word for property damage Indicates dangers that may result in property damage if the measures for danger avoidance are not followed.
CAUTION	Signal word for minor injury Indicates dangers that may result in minor injury if the measures for danger avoidance are not followed.
WARNING	Signal word for serious injury Indicates dangers that may result in severe or fatal injury if the measures for danger avoidance are not followed.
DANGER	Signal word for life-threatening danger Indicates dangers with which serious or fatal injury is imminent if the measures for danger avoidance are not followed.

Table 1.2: Other symbols



	Symbol for tips Text passages with this symbol provide you with further information.
	Symbols for action steps Text passages with this symbol instruct you to perform actions.

Table 1.3: Terms and abbreviations

AOPD	Active Optoelectronic Protective Device <b>Active Optoelectronic Protective Device</b>
EDM	Contactormonitoring <b>(External Device Monitoring)</b>
LED	LED, display element in transmitter and receiver
MLC	Brief description of the safety sensor, consisting of transmitter and receiver
MTTF <sub>d</sub>	Mean time to a dangerous failure <b>(Mean Time To dangerous Failure)</b>
OSSD	Safety-related switching output <b>(Output Signal Switching Device)</b>
PFH <sub>d</sub>	Probability of a dangerous Failure per Hour <b>Probability of dangerous Failure per Hour</b>
PL	<b>Performance Level</b>
RES	Start/restart interlock <b>(Start/REStart interlock)</b>
Scan	Consecutive scans of the protective field from the first to the last beam

Safety sensor	System consisting of transmitter and receiver
SIL	<b>Safety Integrity Level</b>
State	ON: device intact, OSSD switched on OFF: device intact, OSSD switched off Locking: device, connection or control / operation faulty, OSSD switched off (lock-out)

## 1.2 Checklists

The checklists (see chapter 9) serve as a reference for the machine manufacturer or supplier. They replace neither testing of the complete machine or system prior to the initial start-up nor their periodic testing by a competent person. The checklists contain minimum testing requirements. Depending on the application, other tests may be necessary.

## 2 Safety

Before using the safety sensor, a risk assessment must be performed according to valid standards (e.g. EN ISO 12100, EN ISO 13849-1, IEC 61508, EN IEC 62061). The result of the risk assessment determines the required safety level of the safety sensor (see table 14.2). For mounting, operating and testing, this document as well as all applicable national and international standards, regulations, rules and directives must be observed. Relevant and supplied documents must be observed, printed out and handed to affected persons.

 Before working with the safety sensor, completely read and understand the documents applicable to your task.

In particular, the following national and international legal regulations apply for the start-up, technical inspections and work with safety sensors:

- Machinery directive 2006/42/EC
- Low voltage directive 2006/95/EC
- EMC directive 2004/108/EC
- Use of Work Equipment Directive 89/655/EEC supplemented by Directive 95/63 EC
- OSHA 1910 Subpart O
- Safety regulations
- Accident-prevention regulations and safety rules
- Industrial safety regulation and employment protection act
- Product Safety Law (ProdSG)





For safety-related information you may also contact the local authorities (e.g., industrial inspectorate, employer's liability insurance association, labor inspectorate, occupational safety and health authority).

### 2.1 Approved purpose and foreseeable improper operation

 **WARNING**

**A running machine may result in serious injury!**

 Make certain that the safety sensor is correctly connected and that the protective function of the protective device is ensured.

 Make certain that, during all conversions, maintenance work and inspections, the system is securely shut down and protected against being restarted.

### 2.1.1 Proper use

- The safety sensor may only be used after it has been selected in accordance with the respectively applicable instructions and relevant standards, rules and regulations regarding labor protection and safety at work, and after it has been installed on the machine, connected, commissioned, and checked by a **competent person** (see chapter 2.2).
- When selecting the safety sensor it must be ensured that its safety-related capability meets or exceeds the required performance level PL, ascertained in the risk assessment (see table 14.2).
- The safety sensor protects persons or body parts at points of operation, danger zones or access points of machines and plants.
- With the “access guarding” function, the safety sensor detects persons only when they enter the danger zone but cannot tell whether there are any persons inside the danger zone. For this reason, a start/restart interlock in the safety chain is essential in this case.
- The construction of the safety sensor must not be altered. When manipulating the safety sensor, the protective function is no longer guaranteed. Manipulating the safety sensor also voids all warranty claims against the manufacturer of the safety sensor.
- The safety sensor must be inspected regularly by a competent person to ensure proper integration and mounting (see chapter 2.2).
- The safety sensor must be exchanged after a maximum of 20 years. Repairs or the exchange of parts subject to wear and tear do not extend the service life.

### 2.1.2 Foreseeable misuse

Any use other than that defined under the “Approved purpose” or which goes beyond that use is considered improper use.

In principle, the safety sensor is **not** suitable as a protective device for use in the following cases:

- Danger posed by ejected objects or the spraying of hot or hazardous liquids from within the danger zone
- applications in explosive or easily flammable atmospheres

## 2.2 Competent persons

Prerequisites for competent persons:

- They have a suitable technical education.
- They know the rules and regulations for occupational safety, safety at work and safety technology and can assess the safety of the machine.
- They know the instructions for the safety sensor and the machine.
- They have been instructed by the responsible person on the mounting and operation of the machine and of the safety sensor.<sup>1</sup>

## 2.3 Responsibility for safety

Manufacturer and operating company must ensure that the machine and implemented safety sensor function properly and that all affected persons are adequately informed and trained.

The type and content of all imparted information must not lead to unsafe actions by users.

The manufacturer of the machine is responsible for:

- safe machine construction
- safe implementation of the safety sensor, verified by the initial test performed by a competent person
- imparting all relevant information to the operating company
- adhering to all regulations and directives for the safe starting-up of the machine

---

1. They perform a task related to the subject matter shortly thereafter and keep their knowledge up to date through continuous further training.



The operator of the machine is responsible for:

- instructing the operator
- maintaining the safe operation of the machine
- adhering to all regulations and directives for labor protection and safety at work
- regular testing by competent persons

## **2.4 Disclaimer**

Leuze electronic GmbH + Co. KG is not liable in the following cases:

- safety sensor is not used as intended
- safety notices are not adhered to
- reasonably foreseeable misuse is not taken into account
- mounting and electrical connection are not properly performed
- proper function is not tested (see chapter 9)
- changes (e.g., constructional) are made to the safety sensor

### 3 Device description

The safety sensors from the MLC 300series are active opto-electronic protective devices. They satisfy the following standards:

	MLC 300
Type in accordance with EN IEC 61496	2
Category in accordance with EN ISO 13849	2
Performance Level (PL) in accordance with EN ISO 13849-1	c
Safety Integrity Level (SIL) in accordance with IEC 61508 and SILCL in accordance with EN IEC 62061	1

The safety sensor consists of a transmitter and a receiver (see figure 3.1). It is protected against over-voltage and overcurrent acc. to IEC 60204-1 (safety class 3). Its infrared beams are not influenced by ambient light (e.g. welding sparks, warning lights).

#### 3.1 Device overview

The series is characterized by two different receiver classes (Basic, Standard) with certain features and properties (see table 3.1).

Table 3.1: Device models in the series with specific features and functions

	Transmitter	Receivers	
		Basic	Standard
	MLC 300 MLC 301	MLC 310 MLC 311	MLC 320
OSSDs (2x)		•	•
Transmission channel changeover	•	•	•
LED display	•	•	•
7-segment display			•
Automatic start/restart		•	•
RES			•
EDM			•
Range reduction	•		

#### Protective field properties

The beam distance and the number of beams are dependent on the resolution and protective field height.

 Depending on the resolution, the effective protective field height can be larger than the optically active area of the safety sensor housed in yellow (see figure 3.1 and see figure 14.1).

#### Device synchronization

The synchronization of receiver and transmitter for creating a functioning protective field is done optically, i.e. without cables, via two specially coded synchronization beams. A cycle (i.e. a pass from the first to the last beam) is called a scan. The length of a scan determines the length of the response time and affects the calculation of the safety distance (see chapter 6.1.1).

 For the correct synchronization and function of the safety sensor, at least one of the two synchronization beams must be free during synchronization and operation.

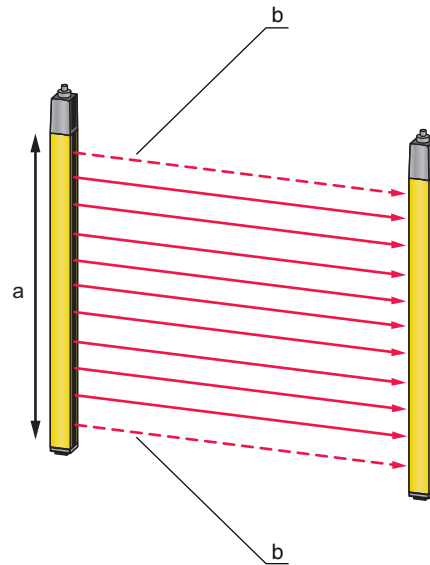

- a     Optically active area, housed in yellow
- b     Synchronization beams

Figure 3.1: Transmitter-receiver system

**QR code**

A QR code as well as the corresponding web address are located on the safety sensor (see figure 3.2). At the web address, you will find device information and error messages (see chapter 11.3 „Error messages 7-segment display“) after scanning the QR code with a mobile end device or after entering the web address. When using mobile end devices, mobile service charges can accrue.



[www.mobile.leuze.com/mlc/](http://www.mobile.leuze.com/mlc/)

Figure 3.2: QR code with corresponding web address (URL) on the safety sensor

**3.2 Connection technology**

The transmitter and receiver feature an M12 connector as an interface to the machine control with the following number of pins:

Device version	Device type	Device plug
MLC 300	Transmitter	5-pin
MLC 320	Receiver standard	8-pin

**3.3 Display elements**

The display elements of the safety sensors simplify start-up and fault analysis.

**3.3.1 Operating indicators on the MLC 300 transmitter**

Two LEDs for displaying the function are located on the connection cap.

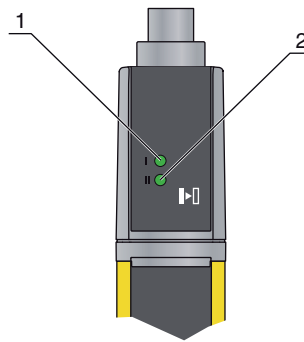

- 1 LED1, green/red
- 2 LED2, green

Figure 3.3: Indicators on the MLC 300 transmitter

Table 3.2: Meaning of the LEDs

LED	Color	State	Description
1	Green/red	OFF	Device switched off
		red	Device error
		green	Normal operation
2	green	Flashing	10 s long after switch-on: reduced range selected by the wiring of pin 4
		OFF	Transmission channel C1
		ON	Transmission channel C2

### 3.3.2 Operating indicators on the MLC 320 receiver

Two LEDs and a 7-segment display for showing the operating state are located on the receiver:

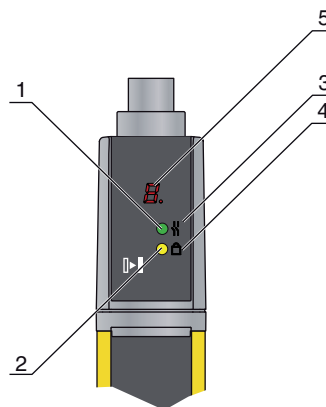

- 1 LED1, red/green
- 2 LED2, yellow
- 3 OSSD icon
- 4 RES icon
- 5 7-segment display

Figure 3.4: Indicators on the MLC 320 receiver

Table 3.3: Meaning of the LEDs

LED	Color	State	Description
1	Red/green	OFF	Device switched off
		red	OSSD off
		Red slowly flashing (approx. 1 Hz)	External fault
		Red flashing fast (approx. 10 Hz)	Internal fault
		Green slowly flashing (approx. 1 Hz)	OSSD on, weak signal
		green	OSSD on
2	yellow	OFF	<ul style="list-style-type: none"> <li>• RES deactivated</li> <li>• or RES activated and enabled</li> <li>• or RES blocked and protective field interrupted</li> </ul>
		ON	RES activated and blocked but ready to be unlocked - protective field free

**7-segment display at the MLC 320 receiver**

In normal operation, the 7-segment display shows the number of the selected transmission channel. In addition, it helps during the detailed error diagnostics (see chapter 11) and serves as an alignment aid (see chapter 8.2 „Alignment the sensor“).

Table 3.4: Meaning of the 7-segment display

Display	Description
<b>After switching on</b>	
8	Self test
t n n	Response time (t) of the receiver in milliseconds (n n)
<b>In normal operation</b>	
C1	Transmission channel C1
C2	Transmission channel C2
<b>For alignment</b>	
	Alignment display (see table 3.5). <ul style="list-style-type: none"> <li>• Segment 1: beam area in upper third of the protective field</li> <li>• Segment 2: beam area in middle third of the protective field</li> <li>• Segment 3: beam area in lower third of the protective field</li> </ul>
<b>For error diagnostics</b>	
F...	Failure, internal device error
E...	Error, external error
U...	Usage info, application error

For error diagnostics, the error's respective letter is displayed first followed by the number code. The display is repeated cyclically. An AutoReset is carried out after 10 s for errors that do not cause locking,

with an unauthorized restart being impossible. In the case of blocking errors, the voltage supply must be separated and the cause of the error must be eliminated. Before switching on again, the steps taken before initial commissioning must be repeated (see chapter 9.1).

The 7-segment display switches to alignment mode when the device has not yet been aligned or when the protective field has been interrupted (after 5 s). In this case, a fixed beam area from the protective field is assigned to every segment.

**3.3.3 Alignment display**

Approximately 5 s after a protective-field interruption, the 7-segment display switches to alignment mode. In this mode, one third of the total protective field (top, middle, bottom) is assigned to one of the three horizontal segments and the state of this sub-protective field displayed as follows:

Table 3.5: Meaning of the alignment display

Segment	Description
Switched on	All beams in the beam area are free.
Flashing	At least one, but not all beams in the beam area are free.
Switched off	All beams in the beam area are interrupted.

When the protective field has been free for about 5 s, the device switches back to the display of the operating mode.

## 4 Functions

An overview of features and functions of the safety sensor can be found in chapter "Device description" (see chapter 3.1 „Device overview“).

Depending on the function required, select the suitable operating mode via corresponding electrical wiring (see chapter 7 „Electrical connection“).

### Overview of functions

- Start/restart interlock (RES)
- EDM
- Range reduction
- Transmission channel changeover

### 4.1 Start/restart interlock RES

After accessing the protective field, the start/restart interlock ensures that the safety sensor remains in the OFF state after the protective field has been cleared. It prevents automatic release of the safety circuits and automatic start-up of the system, e.g. if the protective field is again clear or if an interruption in the voltage supply is restored.



For access guarding, the start/restart interlock function is mandatory. The protective device may only be operated without start/restart interlock in certain exceptional cases and under certain conditions acc. to EN ISO 12100.



#### WARNING

**Deactivation of the start/restart interlock may result in serious injury!**

↪ implement the start/restart interlock on the machine or in a downstream safety circuit.

#### Use start/restart interlock

↪ Wire the MLC 320 receiver appropriately for the desired operating mode (see chapter 7 „Electrical connection“)

The start/restart interlock function is automatically activated.

Switching the safety sensor back on after shutting down (OFF state):

↪ Press the reset button (press/release between 0.1 s and 4 s)



The reset button must be located outside the danger zone in a safe place and give the operator a good view of the danger zone so that he/she can check whether anyone is located in it before pressing the reset button.



#### DANGER

**Risk of death if start/restart is operated unintentionally!**

↪ Ensure that the reset button for unlocking the start/restart interlock cannot be reached from the danger zone.

↪ Before unlocking the start/restart interlock, make certain that no people are in the danger zone.

After the reset button has been actuated, the safety sensor switches to the ON state.

### 4.2 EDM contactor monitoring



The contactor monitoring of the MLC 320 safety sensors can be activated through appropriate wiring (see table 7.3)!

The "contactor monitoring" function monitors the contactors, relays or valves connected downstream of the safety sensor. Prerequisite for this are switching elements with positive-guided feedback contacts (normal closed contacts).

**Implement the contactor monitoring function:**

- through appropriate wiring of the MLC 320 safety sensors (see table 7.3).
- through the external contactor monitoring of the downstream safety relay, (e.g., MSI series from Leuze electronic)
- or through contactor monitoring of the downstream safety PLC (optional, integrated via a safety bus)

If contactor monitoring is activated (see chapter 7 „Electrical connection“), it operates dynamically, i.e., in addition to monitoring the closed feedback circuit every time before the OSSDs are switched on, it also checks whether the release of the feedback circuit opened within 500 ms and, after the OSSDs are switched off, whether it has closed again within 500 ms. If this is not the case, the OSSDs return to the OFF state after being switched on briefly. An error message appears on the 7-segment display (E30, E31) and the receiver switches to the fault interlock state from which it can only be returned to normal operation by switching the supply voltage off and back on again.

**4.3 Transmission channel changeover**

Transmission channels are used to prevent mutual interference of safety sensors which are located close to each other.



To guarantee reliable operation, the infrared beams are modulated so they can be discerned from the ambient light. Welding sparks or warning lights, e.g. from passing high-lift trucks, thereby do not influence the protective field.

With the factory setting, the safety sensor works in all operating modes with transmission channel C1.

The transmission channel of the transmitter can be switched by changing the supply voltage polarity (see chapter 7.1.1 „MLC 300 transmitter“).

The transmission channel of the receiver can be switched by changing the supply voltage polarity (see chapter 7.1.2 „MLC 320 receiver“).



**Faulty function due to incorrect transmission channel!**

Select the same transmission channel on the transmitter and corresponding receiver.

**4.4 Range reduction**

In addition to selecting the suitable transmission channels (see chapter 4.3 „Transmission channel changeover“), the range reduction also serves to prevent mutual interference of adjacent safety sensors. Activating the function reduces the light power of the transmitter so that around half of the nominal range is reached.

**Reducing range:**

↳ Wire pin 4 (see chapter 7.1 „Pin assignment transmitter and receiver“).

The wiring of pin 4 determines the transmitting power and thereby the range.

	<p><b>WARNING</b></p>
<p><b>Impairment of the protective function due to incorrect transmitting power!</b></p> <p>The light power emitted from the transmitter is reduced through a single channel and without safety-relevant monitoring.</p> <p>↳ Do not use this configuration option for safety purposes.</p> <p>↳ Note that the distance to reflective surfaces must always be selected so that no reflection bypass can occur even at maximum transmitting power. (see chapter 6.1.4 „Minimum distance to reflective surfaces“)</p>	



## 5 Applications

The safety sensor only creates square protective fields.

### 5.1 Point of operation guarding

Point of operation guarding for hand and finger protection is typically the most common application for this safety sensor. In accordance with EN ISO 13855, resolutions from 14 to 40 mm make sense here. This yields the necessary safety distance, among others (see chapter 6.1.1 „Calculation of safety distance S“).



Figure 5.1: Point of operation guarding protects reaching into the danger zone, e.g. for cartoners or filling systems

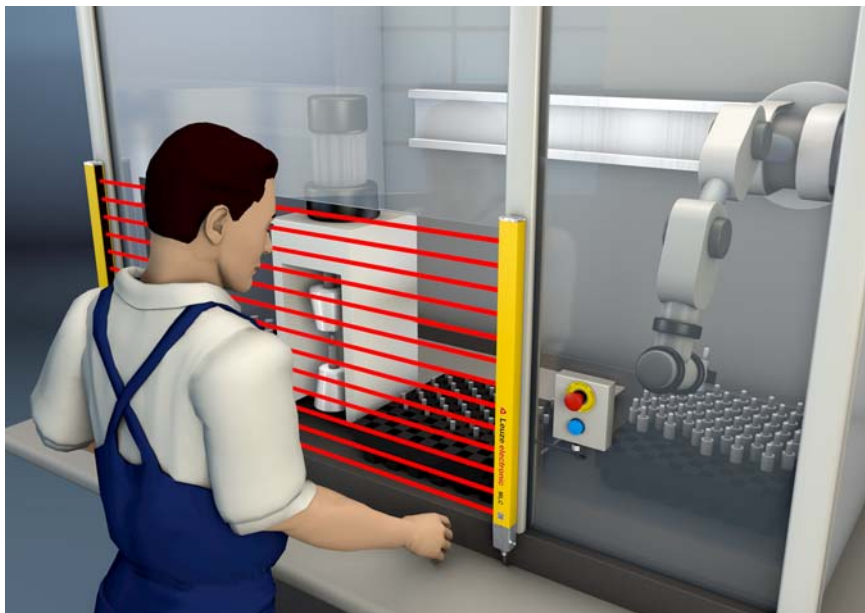

Figure 5.2: Point of operation guarding protects reaching into the danger zone, e.g. for a pick & place robot application

### 5.2 Access guarding

Safety sensors with up to 90 mm resolution are used for access guarding into danger zones. They detect people only upon entry into the danger zone, i.e., they do not detect parts of a person or whether a person is present in the danger zone.

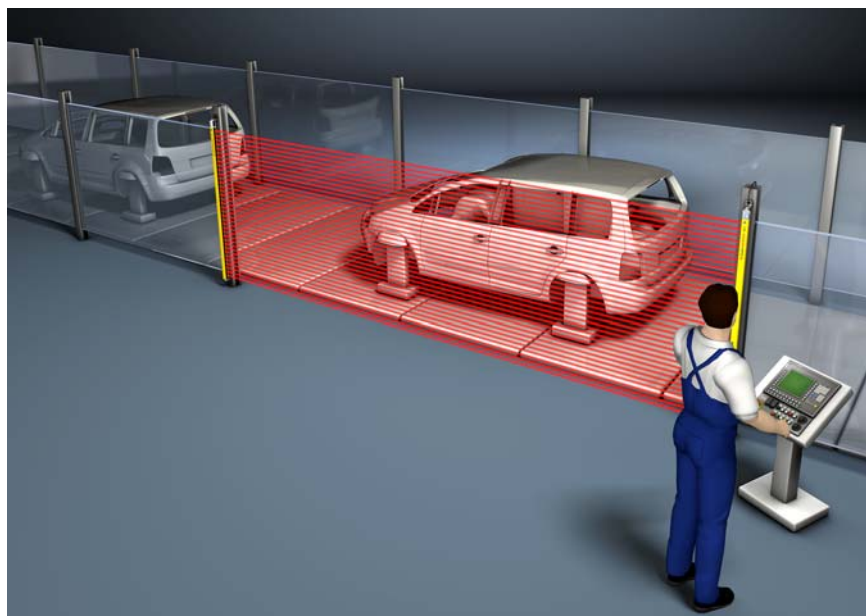

Figure 5.3: Access guarding on a transfer path

### 5.3 Danger zone guarding

Safety Light Curtains can be used in horizontal arrangement for danger zone guarding - either as stand-alone device for presence monitoring or as stepping behind protection for presence monitoring e.g. in combination with a vertically-arranged safety sensor. Depending on the mounting height, resolutions of 40 or 90 mm are used (see table 15.3).

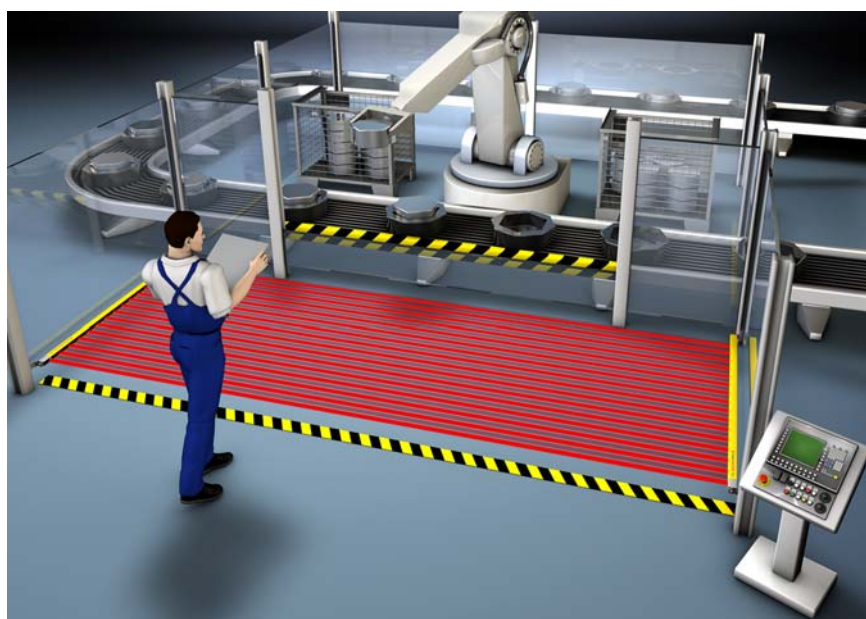



Figure 5.4: Danger zone guarding on a robot

## 6 Mounting

 **WARNING**

**Improper mounting may result in serious injury!**

The protective function of the safety sensor is only ensured if appropriately and professionally mounted for the respective, intended area of application.

- ↳ Only allow competent persons to install the safety sensor.
- ↳ Maintain the necessary safety distances (see chapter 6.1.1).
- ↳ Make sure that stepping behind, crawling under or stepping over the protective device is reliably ruled out and reaching under, over or around is taken into account in the safety distance, if applicable with additional distance  $C_{RO}$  corresponding to EN ISO 13855.
- ↳ Take measures to prevent that the safety sensor can be used to gain access to the danger zone, e.g. by stepping or climbing into it.
- ↳ Observe the relevant standards, regulations and these instructions.
- ↳ Clean the transmitter and receiver at regular intervals: environmental conditions (see chapter 14), care (see chapter 10).
- ↳ After mounting, check the safety sensor for proper function.

### 6.1 Arrangement of transmitter and receiver

Optical protective devices can only perform their protective function if they are mounted with adequate safety distance. When mounting, all delay times must be taken into account, such as the response times of the safety sensor and control elements as well as the stopping time of the machine, among others.

The following standards specify calculation formulas:

- prEN IEC 61496-2, "Active Optoelectronic Protective Devices": distance of the reflecting surfaces/ Deflecting Mirrors
- EN 13855, "Safety of machines - The positioning of protective equipment in respect of approach speeds of parts of the human body": mounting situation and safety distances



In accordance with ISO 13855, with a vertical protective field, it is possible to pass under beams over 300 mm or pass over beams under 900 mm. If the protective field is horizontal, climbing on the safety sensor must be prevented through suitable installation or with covers and the like.

#### 6.1.1 Calculation of safety distance S

**General formula for calculating the safety distance S of an Optoelectronic Protective Device acc. to EN ISO 13855:**

$$S = K \cdot T + C$$

S	[mm]	= Safety distance
K	[mm/s]	= Approach speed
T	[s]	= Total time of the delay, sum from ( $t_a + t_i + t_m$ )
$t_a$	[s]	= Response time of the protective device
$t_i$	[s]	= Response time of the Safety Relay
$t_m$	[s]	= Stopping time of the machine
C	[mm]	= Additional distance to the safety distance



If longer stopping times are determined during regular inspections, an appropriate additional time must be added to  $t_m$ .

### 6.1.2 Calculation of safety distance $S_{RT}$ or $S_{RO}$ if protective fields act orthogonally to the approach direction

With vertical protective fields, EN ISO 13855 differentiates between

- $S_{RT}$ : safety distance concerning access **through** the protective field
- $S_{RO}$ : safety distance concerning access **over** the protective field

The two values are distinguished by the way additional distance C is determined:

- $C_{RT}$ : from a calculation formula or as a constant see chapter 6.1.1 „Calculation of safety distance S“
- $C_{RO}$ : from a table (see table 6.1)

The larger of the two values  $S_{RT}$  and  $S_{RO}$  is to be used.

**Calculation of safety distance  $S_{RT}$  acc. to EN ISO 13855 when access occurs through the protective field:**

**Calculation of safety distance  $S_{RT}$  for point of operation guarding**

$$S_{RT} = K \cdot T + C_{RT}$$

$S_{RT}$	[mm]	= Safety distance
K	[mm/s]	= Approach speed for point of operation guarding with approach reaction and normal approach direction to the protective field (resolution 14 to 40 mm): 2000 mm/s or 1600 mm/s, when $S_{RT} > 500$ mm
T	[s]	= Total time of the delay, sum from ( $t_a + t_i + t_m$ )
$t_a$	[s]	= Response time of the protective device
$t_i$	[s]	= Response time of the Safety Relay
$t_m$	[s]	= Stopping time of the machine
$C_{RT}$	[mm]	= Additional distance for point of operation guarding with approach reaction with resolutions of 14 to 40 mm, $d$ = resolution of protective device $C_{RT} = 8 \cdot (d - 14)$ mm

#### Calculation example

The feeding-in area in a press with a stopping time (including press Safety PLC) of 190 ms is to be safeguarded with a Safety Light Curtain with 20 mm of resolution and 1200 mm of protective field height. The Safety Light Curtain has a response time of 22 ms.

↳ Calculate safety distance  $S_{RT}$  using the formula acc. to EN ISO 13855.

$$S_{RT} = K \cdot T + C_{RT}$$

K	[mm/s]	= 2000
T	[s]	= (0.022 + 0.190)
$C_{RT}$	[mm]	= $8 \cdot (20 - 14)$
$S_{RT}$	[mm]	= $2000 \text{ mm/s} \cdot 0.212 \text{ s} + 48 \text{ mm}$
<b><math>S_{RT}</math></b>	<b>[mm]</b>	<b>= 472</b>

$S_{RT}$  is smaller than 500 mm; this is why the calculation may **not** be repeated with 1600 mm/s.



Implement the stepping behind protection required here, e.g., through the use of an additional or cascaded safety sensor for area protection.

#### Calculation of safety distance $S_{RT}$ for access guarding

$$S_{RT} = K \cdot T + C_{RT}$$

$S_{RT}$	[mm]	= Safety distance
K	[mm/s]	= Approach speed for access guarding with approach direction orthogonal to the protective field: 2000 mm/s or 1600 mm/s, if $S_{RT} > 500$ mm
T	[s]	= Total time of the delay, sum from ( $t_a + t_i + t_m$ )
$t_a$	[s]	= Response time of the protective device
$t_i$	[s]	= Response time of the Safety Relay
$t_m$	[s]	= Stopping time of the machine
$C_{RT}$	[mm]	= Additional distance for access guarding with approach reaction with resolutions of 14 to 40 mm, $d$ = resolution of protective device $C_{RT} = 8 \cdot (d - 14)$ mm. Additional dis-

tance for access guarding for resolutions > 40 mm:  $C_{RT} = 850$  mm (standard value for arm length)

### Calculation example

Access to a robot with a stopping time of 250 ms is to be safeguarded with a Safety Light Curtain with 90 mm of resolution and 1500 mm of protective field height whose response time is 6 ms. The Safety Light Curtain directly switches the contactors whose response time is contained in the 250 ms. An additional interface therefore does not have to be taken into consideration.

↪ Calculate safety distance  $S_{RT}$  using the formula acc. to EN ISO 13855.

$$S_{RT} = K \cdot T + C_{RT}$$

K	[mm/s]	= 1600
T	[s]	= (0.006 + 0.250)
$C_{RT}$	[mm]	= 850
$S_{RT}$	[mm]	= 1600 mm/s · 0.256 s + 850 mm
<b><math>S_{RT}</math></b>	<b>[mm]</b>	<b>= 1260</b>

This safety distance is not available in the application. This is why a new calculation is done with a Safety Light Curtain with 40 mm of resolution (response time = 14 ms):

↪ Re-calculate safety distance  $S_{RT}$  using the formula acc. to EN ISO 13855.

$$S_{RT} = K \cdot T + C_{RT}$$

K	[mm/s]	= 1600
T	[s]	= (0.014 + 0.250)
$C_{RT}$	[mm]	= 8 · (40 - 14)
$S_{RT}$	[mm]	= 1600 mm/s · 0.264 s + 208 mm
<b><math>S_{RT}</math></b>	<b>[mm]</b>	<b>= 631</b>

The Safety Light Curtain with a 40 mm resolution is thus suitable for this application.



For the calculation with  $K = 2000$  mm/s, safety distance  $S_{RT}$  equals 736 mm. The adoption of approach speed  $K = 1600$  mm/s is therefore permitted.

**Calculation of safety distance  $S_{RO}$  acc. to EN ISO 13855 when protective field is accessed from above:**

**Calculation of safety distance  $S_{RT}$  for point of operation guarding**

$$S_{RO} = K \cdot T + C_{RO}$$

$S_{RO}$	[mm]	= Safety distance
K	[mm/s]	= Approach speed for point of operation guarding with approach reaction and normal approach direction to the protective field (resolution 14 to 40 mm): 2000 mm/s or 1600 mm/s, when $S_{RO} > 500$ mm
T	[s]	= Total time of the delay, sum from ( $t_a + t_i + t_m$ )
$t_a$	[s]	= Response time of the protective device
$t_i$	[s]	= Response time of the Safety Relay
$t_m$	[s]	= Stopping time of the machine
$C_{RO}$	[mm]	= Additional distance in which a body part can move towards the protective device before the protective device triggers: value (see table 6.1)

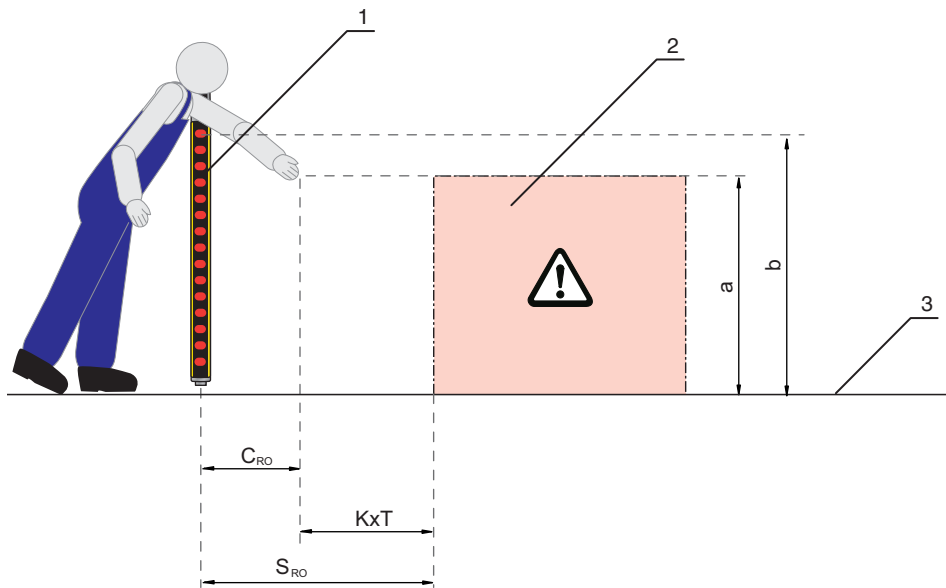

- 1 Safety sensor
- 2 Danger zone
- 3 Floor
- a Height of the point of operation
- b Height of the upper beam of the safety sensor

Figure 6.1: Additional distance to the safety distance when reaching over and under

Table 6.1: Reaching over the vertical protective field of electro-sensitive protective equipment(excerpt from EN ISO 13855)

Height a of the point of operation [mm]	Height b of the upper edge of the protective field of the electro-sensitive protective equipment											
	900	1000	1100	1200	1300	1400	1600	1800	2000	2200	2400	2600
Additional distance $C_{RO}$ to the danger zone [mm]												
2600	0	0	0	0	0	0	0	0	0	0	0	0
2500	400	400	350	300	300	300	300	300	250	150	100	0
2400	550	550	550	500	450	450	400	400	300	250	100	0
2200	800	750	750	700	650	650	600	550	400	250	0	0
2000	950	950	850	850	800	750	700	550	400	0	0	0
1800	1100	1100	950	950	850	800	750	550	0	0	0	0
1600	1150	1150	1100	1000	900	850	750	450	0	0	0	0
1400	1200	1200	1100	1000	900	850	650	0	0	0	0	0
1200	1200	1200	1100	1000	850	800	0	0	0	0	0	0
1000	1200	1150	1050	950	750	700	0	0	0	0	0	0
800	1150	1050	950	800	500	450	0	0	0	0	0	0
600	1050	950	750	550	0	0	0	0	0	0	0	0

Height a of the point of operation [mm]	Height b of the upper edge of the protective field of the electro-sensitive protective equipment											
	900	1000	1100	1200	1300	1400	1600	1800	2000	2200	2400	2600
	Additional distance $C_{RO}$ to the danger zone [mm]											
400	900	700	0	0	0	0	0	0	0	0	0	0
200	600	0	0	0	0	0	0	0	0	0	0	0
0	0	0	0	0	0	0	0	0	0	0	0	0

Depending on the specified values you can work with the above-mentioned table (see table 6.1) in three ways:

1. Given are

- Height a of the point of operation
- Distance S of the point of operation from the safety sensor, and additional distance  $C_{RO}$

To be determined is the required height b of the upper beam of the safety sensor and thereby its protective field height.

- ↪ Look for the line with the specification of the point of operation height in the left column.
- ↪ In this line, look for the column with the next highest specification for additional distance  $C_{RO}$ .
- The required height of the upper beam of the safety sensor is up top in the column head.

2. Given are

- Height a of the point of operation
- Height b of the upper beam of the safety sensor

To be determined is the required distance S of the safety sensor to the point of operation and thereby additional distance  $C_{RO}$ .

- ↪ In the column head, look for the column with the next lowest entry for the height of the upper beam of the safety sensor.
- ↪ Look for the line with the next highest specification of the point of operation height a in this column.
- In the intersection point of the line and the column, you will find additional distance  $C_{RO}$ .

3. Given are

- Distance S of the point of operation from the safety sensor, and additional distance  $C_{RO}$
- Height b of the upper beam of the safety sensor

To be determined is the permitted height a of the point of operation.

- ↪ In the column head, look for the column with the next lowest entry for the height of the upper beam of the safety sensor.
- ↪ Look for the next lowest value for real additional distance  $C_{RO}$  in this column.
- In this line, go to the left column: here you will find the permitted height of the point of operation.
- ↪ Now calculate safety distance S using the general formula acc. to EN ISO 13855, see chapter 6.1.1 „Calculation of safety distance S“.

The larger of the two values SRT or  $S_{RO}$  is to be used.

**Calculation example**

The feeding-in area in a press with a stopping time of 130 ms is to be safeguarded with a Safety Light Curtain with 20 mm of resolution and 600 mm of protective field height. The response time of the Safety Light Curtain is 12 ms; the press Safety PLC has a response time of 40 ms.

The safety sensor can be reached over. The upper edge of the protective field is located at a height of 1400 mm; the point of operation is located at a height of 1000 mm

→ Additional distance  $C_{RO}$  to the point of operation is 700 mm (see table 6.1).

- ↪ Calculate safety distance  $S_{RO}$  using the formula acc. to EN ISO 13855.

$$S_{RO} = K \cdot T + C_{RO}$$

K	[mm/s]	= 2000
T	[s]	= (0.012 + 0.040 + 0.130)
C <sub>RO</sub>	[mm]	= 700
S <sub>RO</sub>	[mm]	= 2000 mm/s · 0.182 s + 700 mm
<b>S<sub>RO</sub></b>	<b>[mm]</b>	<b>= 1064</b>

S<sub>RO</sub> is larger than 500 mm; this is why the calculation may be repeated with approach speed 1600 mm/s:

$$S_{RO} = K \cdot T + C_{RO}$$

K	[mm/s]	= 1600
T	[s]	= (0.012 + 0.040 + 0.130)
C <sub>RO</sub>	[mm]	= 700
S <sub>RO</sub>	[mm]	= 1600 mm/s · 0.182 s + 700 mm
<b>S<sub>RO</sub></b>	<b>[mm]</b>	<b>= 992</b>



Depending on the machine construction, stepping behind protection, e.g. using a second horizontally arranged Safety Light Curtain, is necessary. In most cases, it will be more appropriate to choose a longer Safety Light Curtain which makes the additional distance C<sub>RO</sub> equal to 0.

### 6.1.3 Calculation of safety distance S for parallel approach to the protective field

#### Calculation of safety distance S for danger zone guarding

$$S = K \cdot T + C$$

S	[mm]	= Safety distance
K	[mm/s]	= Approach speed for danger zone guarding with approach direction parallel to the protective field (resolution up to 90 mm): 1600 mm/s
T	[s]	= Total time of the delay, sum from (t <sub>a</sub> + t <sub>i</sub> + t <sub>m</sub> )
t <sub>a</sub>	[s]	= Response time of the protective device
t <sub>i</sub>	[s]	= Response time of the Safety Relay
t <sub>m</sub>	[s]	= Stopping time of the machine
C	[mm]	= Additional distance for danger zone guarding with approach reaction H = height of the protective field, H <sub>min</sub> = minimum installation height permitted, but no smaller than 0, d = resolution of the protective device C = 1200 mm - 0.4 · H; H <sub>min</sub> = 15 · (d - 50)

#### Calculation example

The danger zone in front of a machine with a stopping time of 140 ms is to be safeguarded as close to the floor height as possible using a horizontal Safety Light Curtain as a replacement for a PS mat. Installation height H<sub>min</sub> can be = 0 - additional distance C to the safety distance is then 1200 mm. The shortest possible safety sensor is to be used; the first value to be selected is to be 1350 mm.

The receiver with 40 mm of resolution and 1350 mm protective field height has a response time of 13 ms, an additional MSI-SR4 relay interface a response time of 10 ms.

↪ Calculate safety distance S<sub>RO</sub> using the formula acc. to EN ISO 13855.

$$S = K \cdot T + C$$

K	[mm/s]	= 1600
T	[s]	= (0.140 + 0.013 + 0.010)
C	[mm]	= 1200
S	[mm]	= 1600 mm/s · 0.163 s + 1200 mm
<b>S</b>	<b>[mm]</b>	<b>= 1461</b>

The safety distance of 1350 mm is not sufficient; 1460 mm are necessary.

This is why the calculation is repeated with a protective field height of 1500 mm. The response time is now 14 ms.



↪ Re-calculate safety distance  $S_{RO}$  using the formula according to EN ISO 13855.

$$S = K \cdot T + C$$

K	[mm/s]	= 1600
T	[s]	= (0.140 + 0.014 + 0.010)
C	[mm]	= 1200
S	[mm]	= 1600 mm/s · 0.164 s + 1200 mm
<b>S</b>	<b>[mm]</b>	<b>= 1463</b>

A suitable safety sensor has been found; its protective field height is 1500 mm.

6.1.4 Minimum distance to reflective surfaces

**⚠ WARNING**

**Failure to maintain minimum distances to reflective surfaces may result in serious injury!**

Reflective surfaces can indirectly deflect the transmitter beams to the receiver. In this case, interruption of the protective field is not detected.

↪ Determine the minimum distance a (see figure 6.2).

↪ Make certain that all reflective surfaces are the necessary minimum distance away from the protective field according to prEN IEC 61496-2 (see figure 6.3).

↪ Check that reflective surfaces do not impair the detection capability of the safety sensor before start-up and at appropriate intervals.

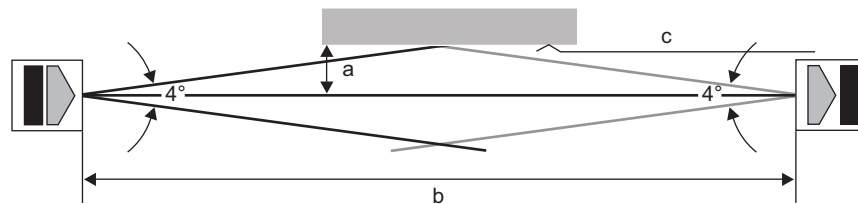

- a Required minimum distance to reflective surfaces [mm]
- b Protective field width [m]
- c Reflective surface

Figure 6.2: Minimum distance to reflective surfaces depending on protective field width

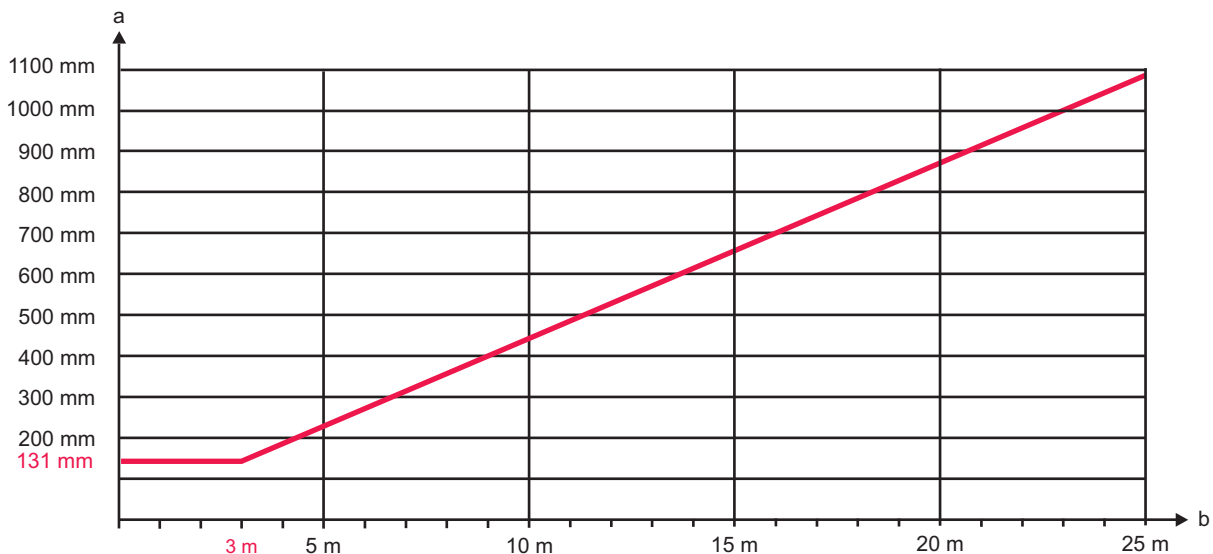

- a Required minimum distance to reflective surfaces [mm]
- b Protective field width [m]

Figure 6.3: Minimum distance to reflective surfaces as a function of the protective field width

Table 6.2: Formula for calculating the minimum distance to reflective surfaces

Distance (b) transmitter-receiver	Calculation of the minimum distance (a) to reflective surfaces
$b \leq 3 \text{ m}$	$a \text{ [mm]} = 131$
$b > 3 \text{ m}$	$a \text{ [mm]} = \tan(2.5^\circ) \cdot 1000 \cdot b \text{ [m]} = 43.66 \cdot b \text{ [m]}$

### 6.1.5 Preventing mutual interference between adjacent devices

If a receiver is located in the beam path of an adjacent transmitter, optical crosstalk, and thus erroneous switching and failure of the protective function, may result (see figure 6.4).

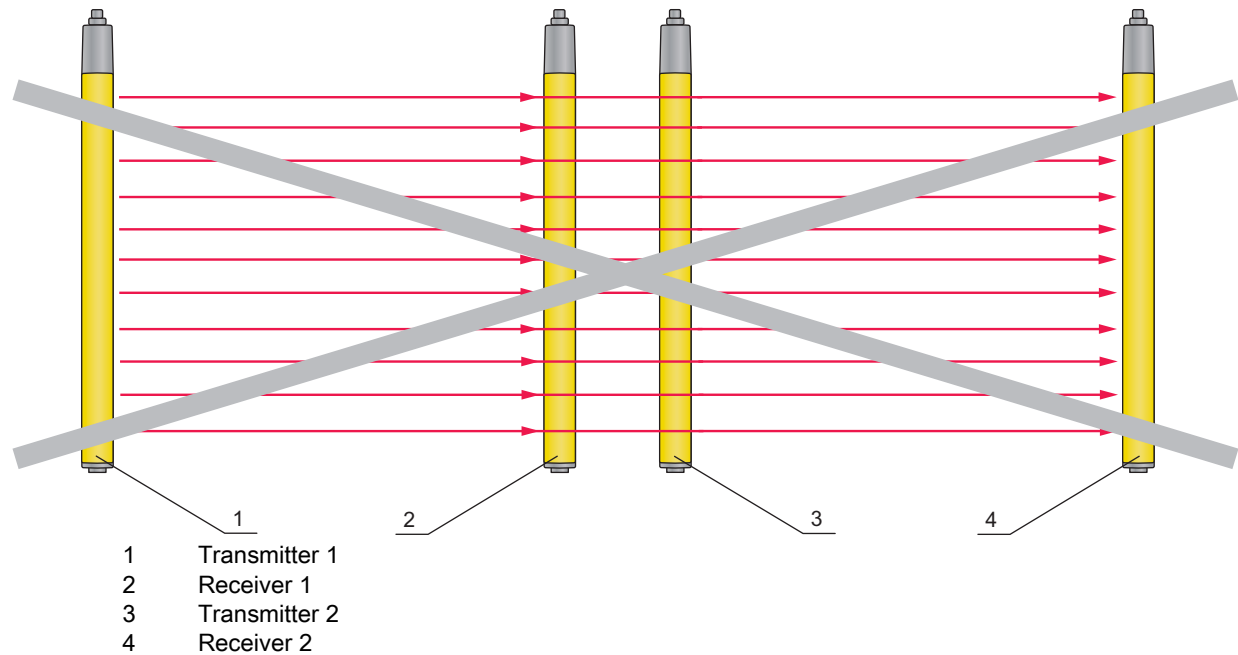

Figure 6.4: Optical crosstalk between adjacent safety sensors (transmitter 1 influences receiver 2) due to incorrect mounting

<b>NOTICE</b>
<b>Possible impairment of the availability due to systems mounted close to each other!</b>
The transmitter of one system can influence the receiver of the other system.
↪ Prevent optical crosstalk between adjacent devices.

↪ Mount adjacent devices with a shield between them or install a dividing wall to prevent mutual interference.

↪ Mount the adjacent devices opposite from one another to prevent mutual interference.

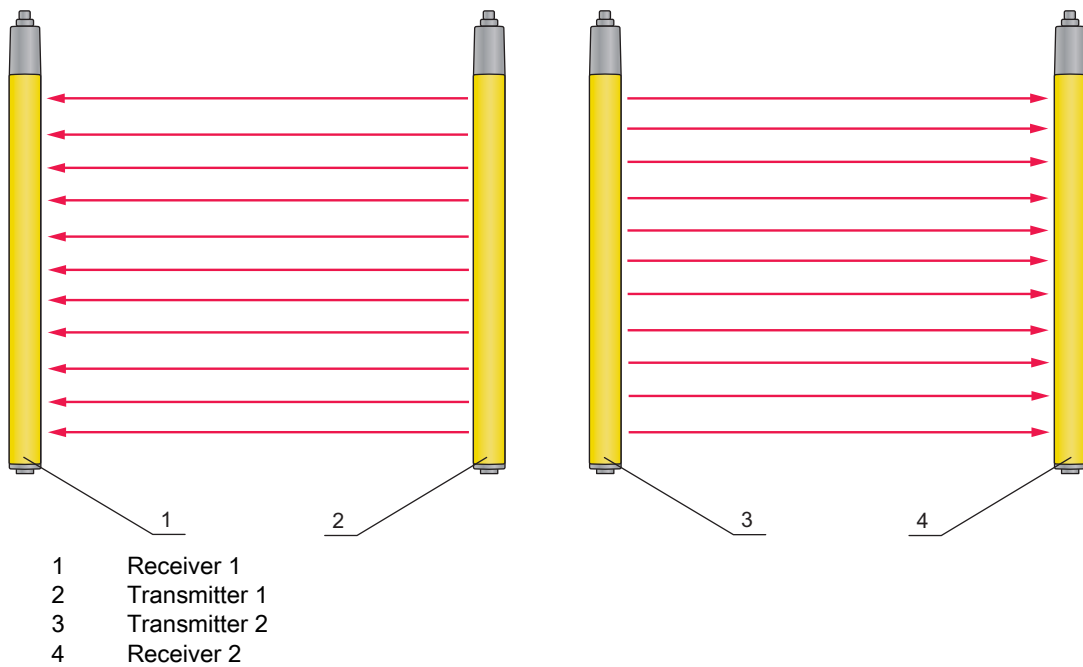

Figure 6.5: Opposite mounting

In addition to design characteristics, the safety sensor offers functions that can remedy this:

- Selectable transmission channels (see chapter 4.3)
- Range reduction (see chapter 4.4)
- Also: opposite mounting

## 6.2 Mounting the safety sensor

Proceed as follows:

- Select the type of fastening, e.g. sliding blocks (see chapter 6.2.3).
- Have a suitable tool at hand and mount the safety sensor in accordance with the notices regarding the mounting locations (see chapter 6.2.1).
- If possible, affix safety notice stickers on the mounted safety sensor or Device Column (included in delivery contents).

After mounting, you can electrically connect (see chapter 7), start up, align (see chapter 8 „Starting up the device“), and test (see chapter 9.1) the safety sensor.

### 6.2.1 Suitable mounting locations

**Area of application:** Mounting

**Tester:** technician who mounts the safety sensor

Table 6.3: Checklist for mounting preparations

Check:	Yes	No
Do the protective field height and dimensions satisfy the requirements of EN 13855?		
Is the safety distance to the point of operation maintained (see chapter 6.1.1)?		
Is the minimum distance to reflective surfaces maintained (see chapter 6.1.4)?		
Is it impossible for safety sensors that are mounted next to one another to mutually interfere with one another (see chapter 6.1.5)?		
Can the point of operation or the danger zone only be accessed through the protective field?		

Check:	Yes	No
Has bypassing the protective field by crawling under, reaching over, or jumping over been prevented or has corresponding additional distance $C_{RO}$ in accordance with EN ISO 13855 been observed?		
Is stepping behind the protective device prevented or is mechanical protection available?		
Do the transmitter and receiver connections point in the same direction?		
Can the transmitter and receiver be fastened in such a way that they cannot be moved and turned?		
Is the safety sensor accessible for testing and replacing?		
Is it impossible to actuate the reset button from within the danger zone?		
Can the entire danger zone be seen from the installation site of the reset button?		
Can reflection caused by the installation site be ruled out?		

**i** If you answer one of the items on the check list (see table 6.3) with *no*, the mounting location must be changed.

**6.2.2 Definition of directions of movement**

The following terms for alignment movements of the safety sensor around one of its axes are used:

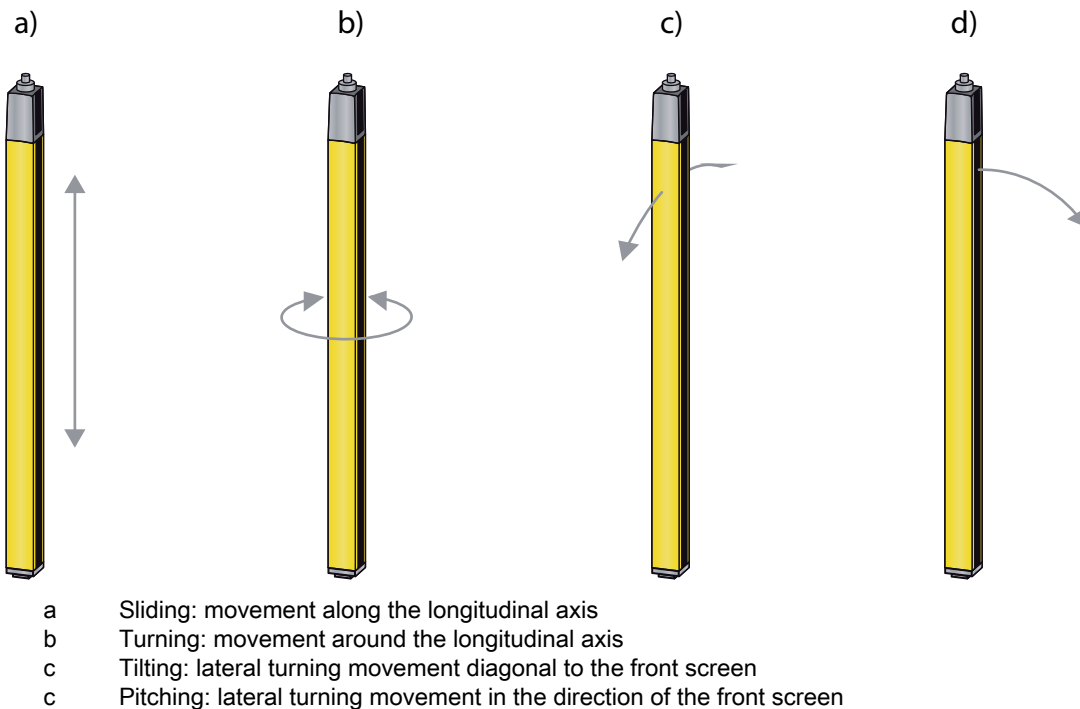

Figure 6.6: Directions of movement during alignment of the safety sensor

**6.2.3 Fastening via BT-NC60 sliding blocks**

By default, transmitter and receiver are delivered with 2 BT-NC60 sliding blocks each in the side slot. This makes fastening the safety sensor to the machine or system to be safeguarded easy via four M6 screws. Sliding in the direction of slot to set the height is possible, but turning, tilting and pitching is not.

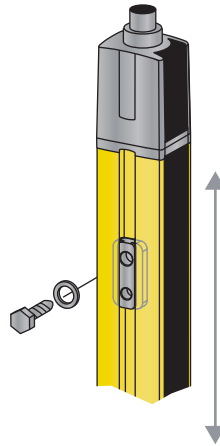

Figure 6.7: Mounting via BT-NC60 sliding blocks

#### 6.2.4 Fastening with BT-R swivel mount

With the swivel mount (see table 15.5), sold separately, the safety sensor can be aligned as follows:

- Sliding through the vertical threaded holes in the wall plate of the swivel mount
- Turning by 360° around the longitudinal axis by fixing on the screw-on cone
- Pitching in the direction of the protective field with horizontal threaded holes in the wall mounting
- Tilting around main axis

The wall mounting through threaded holes makes it possible to lift the mounting bracket after the screws have been loosened over the connection cap. Therefore, the mounting brackets do not need to be removed from the wall when exchanging the device. Loosening the screws is sufficient.

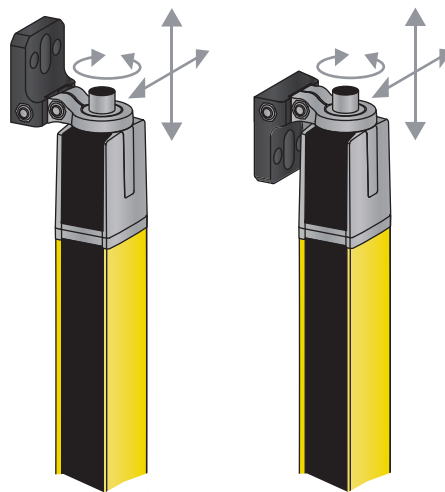

Figure 6.8: Mounting via BT-R swivel mount

#### 6.2.5 One-sided mounting on the machine table

The safety sensor can be mounted directly on the machine table via an M5 screw on the blind hole in the end cap. On the other end, a BT-R swivel mount can be used, for example, so that turning movements for alignment are possible despite the fact that the sensor is mounted on one side. The full resolution of the safety sensor is thus preserved on all points of the protective field down to the machine table.

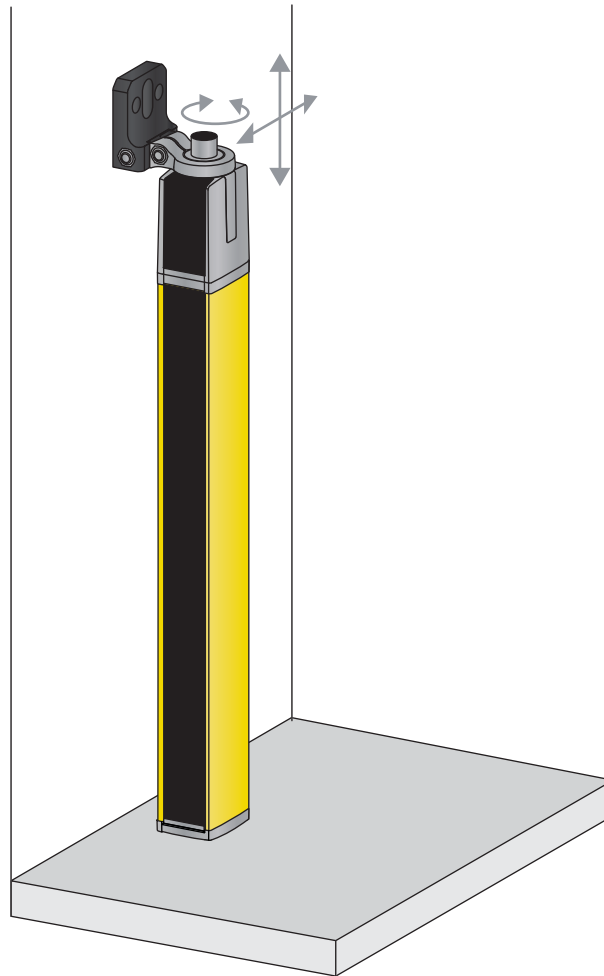

Figure 6.9: Mounting directly on the machine table



#### WARNING

##### Impairment of the protective function due to reflections on the machine table!

- ↳ Make sure that reflections on the machine table are prevented reliably.
- ↳ After mounting and every day after that, check the detection capability of the safety sensor in the entire protective field using a test rod (see figure 9.1).

## 6.3 Mounting accessories

### 6.3.1 Deflecting Mirror for multiple-side guarding

For multiple-side guarding, redirecting the protective field with one or two Deflecting Mirrors is economical. To do this, Leuze electronic supplies

- the UM60 Deflecting Mirror for mounting on the machine in various lengths (see table 15.5)
- suitable BT-UM60 swivel mounts
- UMC-1000-S2 ... UMC-1900-S2 Deflecting Mirror Columns with spring-damped base for free-standing floor mounting

The range is reduced by approx. 10 % per deflection. A laser alignment aid with red light laser is recommended for the alignment of transmitter and receiver (see chapter 8.3 „Aligning of Deflecting Mirrors with the laser alignment aid“).

- ↳ Note that the distance between the transmitter and the first Deflecting Mirror cannot be larger than 3 m.

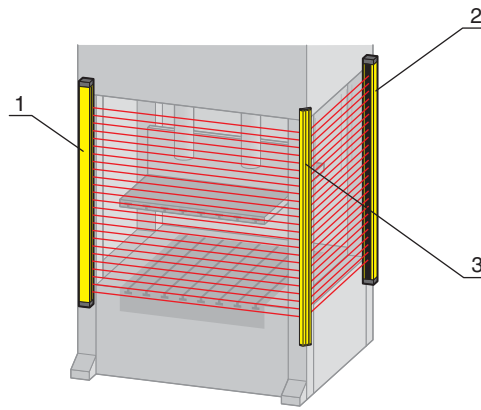

- 1 Transmitter
- 2 Receiver
- 3 UM60 Deflecting Mirror

Figure 6.10: Arrangement with Deflecting Mirror for 2-side guarding of a point of operation

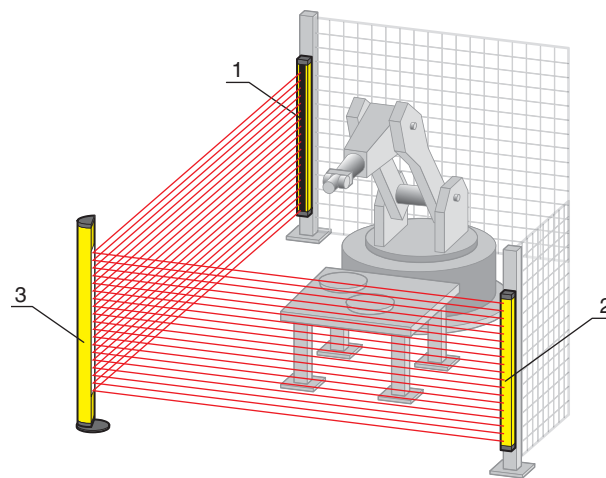

- 1 Transmitter
- 2 Receiver
- 3 UMC Deflecting Mirror Column

Figure 6.11: Arrangement with Deflecting Mirror Columns for two-side guarding of a point of operation

### 6.3.2 MLC-PS protective screen

If there is a risk that the protective plastic screens of the safety sensors could get damaged, e.g. by welding sparks, placing the additional, easy-to-replace MLC-PS protective screen in front of the safety sensors can protect the device protective screen and considerably increase the availability of the safety sensor. Mounting is performed using special clamp brackets, which are fastened on the lateral slot, via an Allen screw accessible from the front on each. The range of the safety sensor is reduced by approx. 5%; when protective screens are used on the transmitter and the receiver it is reduced by 10%. Mounting bracket sets with 2 and 3 clamp brackets are available.



If the length equals 1200 mm or higher, 3 clamp brackets are recommended.

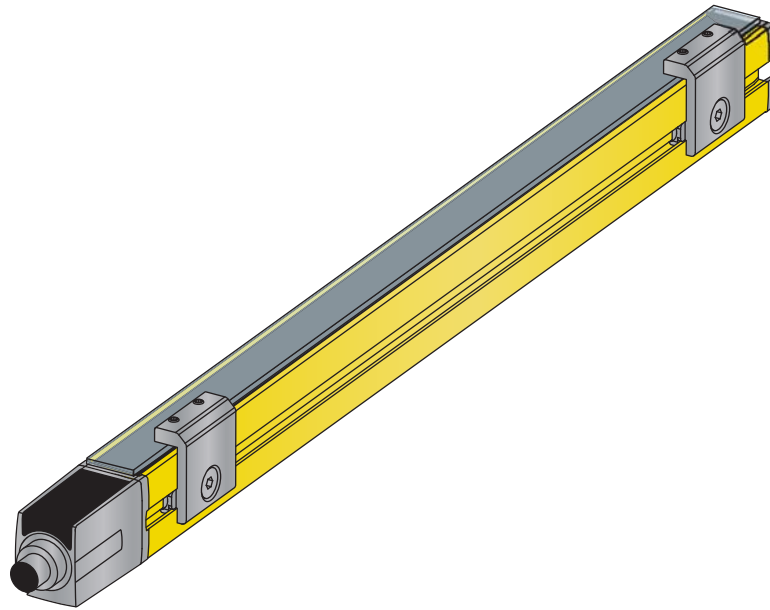

Figure 6.12: MLC-PS protective screen fastened with MLC-2PSF clamp bracket



## 7 Electrical connection

**⚠ WARNING**

**Faulty electrical connection or improper function selection may result in serious injury!**

- ↳ Only allow competent persons to perform the electrical connection.
- ↳ For access guarding, activate the start/restart interlock and make certain that it cannot be unlocked from within the danger zone.
- ↳ Select the functions so that the safety sensor can be used as intended (see chapter 2.1).
- ↳ Select the safety-relevant functions for the safety sensor (see chapter 4 „Functions“).
- ↳ Always loop both safety related switching outputs OSSD1 and OSSD2 into the work circuit of the machine.
- ↳ Signal outputs must not be used for switching safety-relevant signals.

### 7.1 Pin assignment transmitter and receiver

#### 7.1.1 MLC 300 transmitter

MLC 300 transmitters are equipped with a 5-pin M 12 connector.

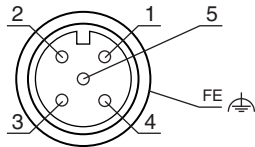

Figure 7.1: Pin assignment transmitter

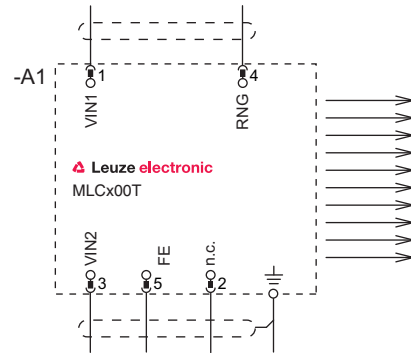

Figure 7.2: Connection diagram transmitter

Table 7.1: Pin assignment transmitter

Pin	Core color (CB-M12-xx000E-5GF)	Transmitter
1	brown	VIN1 - supply voltage
2	white	n.c.
3	Blue	VIN2 - supply voltage
4	black	RNG - range
5	gray	FE - functional earth, shield
Shield		FE - functional earth, shield

The polarity of the supply voltage selects the transmission channel of the transmitter:

- VIN1 = +24 V, VIN2 = 0 V: transmission channel C1
- VIN1 = 0 V, VIN2 = +24 V: transmission channel C2

The wiring of pin 4 determines the transmitting power and thereby the range:

- Pin 4 = +24 V: standard range
- Pin 4 = 0 V or open: reduced range

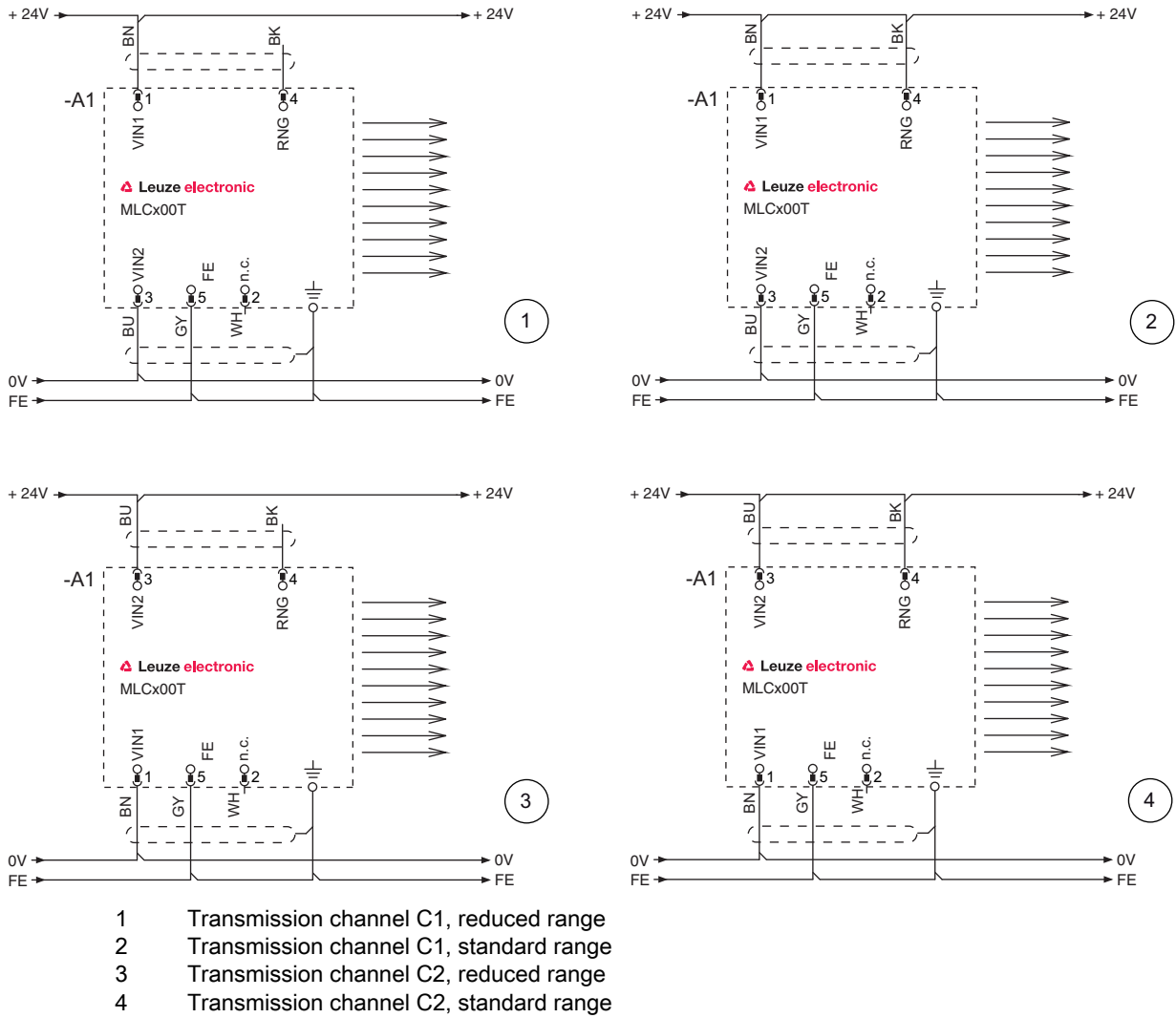

Figure 7.3: Connection examples transmitter



For special EMC influences, the use of shielded cables is recommended.

7.1.2 MLC 320 receiver

Table 7.2:

MLC 320 receivers are equipped with an 8-pin M 12 connector.

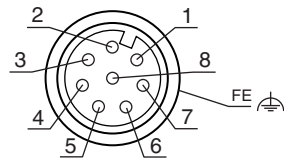

Figure 7.4: Pin assignment receiver

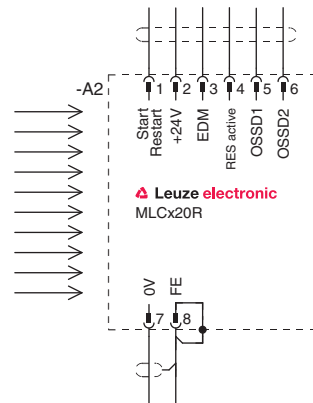

Figure 7.5: Connection diagram receiver

Table 7.3: MLC 320 receiver pin assignment

Pin	Core color (CB-M12-xx000E-5GF)	Receivers
1	white	IO1 - control input reset button, signal output Start/restart normal open contact against ground 24 V DC weak signal/fault: 24 V DC strong light reception 0 V weak light reception or fault
2	brown	VIN1 - supply voltage 24 V DC for transmission channel C1 0 V for transmission channel C2
3	green	IN3 - control-input contactor monitoring (EDM) 24 V DC: without EDM 0 V: with EDM and feedback circuit closed High-impedance: with EDM and feedback circuit open
4	yellow	IN4 - control input for start/restart interlock (RES) 24 V DC: with RES Bridge to pin 1: without RES (notice: signal output remains functional)
5	gray	OSSD1 - safety-related switching output
6	pink	OSSD2 - safety-related switching output
7	Blue	VIN2 - supply voltage 0 V: for transmission channel C1 24 V DC for transmission channel C2
8	red	FE - functional earth, shield Wired in device interior on the housing
Shield		FE - functional earth, shield

The polarity of the supply voltage selects the transmission channel of the transmitter:

- VIN1 = +24 V, VIN2 = 0 V: transmission channel C1
- VIN1 = 0 V, VIN2 = +24 V: transmission channel C2



For special EMC influences, the use of shielded cables is recommended.

## 7.2 Circuit diagram examples

### 7.2.1 MLC 320 circuit diagram example

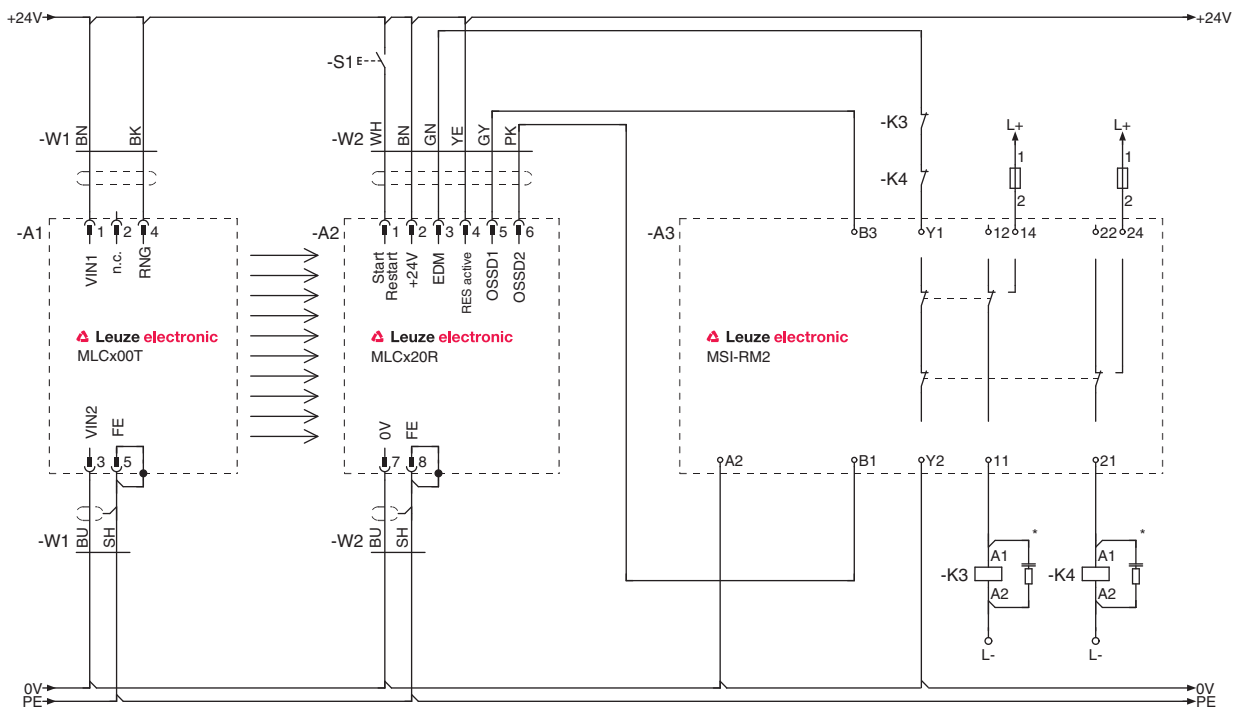

Figure 7.6: Circuit diagram example with downstream MSI-RM2 Safety Relay

## 8 Starting up the device

### WARNING

**Improper use of the safety sensor may result in serious injury!**

- ↪ Make certain that the entire device and the integration of the Optoelectronic Protective Device was inspected by competent and instructed persons.
- ↪ Make certain that a dangerous process can only be started while the safety sensor is switched on.

Prerequisites:

- Safety sensor mounted (see chapter 6 „Mounting“) and connected (see chapter 7 „Electrical connection“) correctly
  - Operating personnel were instructed in proper use.
  - Dangerous process is switched off, outputs of the safety sensor are disconnected, and the system is protected against being switched back on
- ↪ After start-up, check the function of the safety sensor (see chapter 9.1 „Before the initial start-up and following modifications“).

### 8.1 Switching on

Requirements for the supply voltage (power supply unit):

- Reliable mains separation is ensured.
- Current reserve of at least 2 A is available.
- The RES function is activated - either in the safety sensor or in the downstream control

↪ Switch on the safety sensor.

The safety sensor performs a self test and then displays the response time of the receiver. (see table 3.4).

**Check operational readiness of sensor**

↪ Check whether LED1 is permanently lit green or red (see table 3.3).

The safety sensor is ready for use.

### 8.2 Aligning the sensor

#### NOTICE

**Faulty or incorrect alignment may result in an operating fault!**

- ↪ The alignment performed during start-up should only be performed by qualified personnel.
- ↪ Observe the data sheets and mounting instructions of the individual components.

**Prealignment**

Fasten the transmitter and receiver in a vertical or horizontal position and at the same height so that

- the front screens are directed at each other.
- the transmitter and receiver connections point in the same direction.
- the transmitter and receiver are arranged parallel to each other, i.e. they are the same distance from each other at the beginning and end of the device.

Alignment can be performed with a clear protective field by observing the LEDs and the 7-segment display (see chapter 3.3 „Display elements“).

↪ Loosen the screws on the mounting brackets or Device Columns.



Loosen the screws only enough so that the devices can just be moved.

↪ Turn the receiver to the left until LED1 still flashes green but does not yet illuminate red. If necessary, you may have to turn the transmitter beforehand. The receiver with activated alignment display shows flashing segments in the 7-segment display, if applicable.

- ↪ Note the value of the twist angle.
- ↪ Turn the receiver to the right until LED1 still flashes green but does not yet illuminate red.
- ↪ Note the value of the twist angle.
- ↪ Set the optimum position of the receiver. This lies in the middle of the two values for the twist angle to the left and right.
- ↪ Tighten the fastening screws of the receiver.
- ↪ Now align the transmitter according to the same method, paying attention to the display elements of the receiver while doing so (see chapter 0.0.1 „Operating indicators on the MLC 310 receiverOperating indicators on the MLC 311 receiverOperating indicators on the MLC 510 receiverOperating indicators on the MLC 511 receiver“, see chapter 3.3.2 „Operating indicators on the MLC 320 receiver“).

### 8.3 Aligning of Deflecting Mirrors with the laser alignment aid

When using Deflecting Mirrors for multiple-side point of operation guarding and access guarding in particular, an external laser alignment aid is recommended (see table 15.5).



With its clearly visible red light spot, the external laser alignment aid facilitates the correct setting of the transmitter and receiver as well as the Deflecting Mirrors.

- ↪ Fasten the laser alignment aid on top on the side groove of the transmitter (mounting instructions are included in the accessories).
- ↪ Switch on the laser. Take note of the operating instructions of the laser alignment aid concerning the safety notices and the activation of the laser alignment aid.
- ↪ Loosen the mounting bracket of the transmitter and turn or tilt or pitch the device so that the laser spot strikes the top of the first Deflecting Mirror (see chapter 6.2.2 „Definition of directions of movement“).
- ↪ Now set the laser below on the transmitter and adjust it so that the laser spot strikes the bottom of the Deflecting Mirror.
- ↪ Now set the laser back up top on the transmitter and check if the laser spot still strikes the top of the Deflecting Mirror. If it does not, the mounting height of the transmitter must be changed, if applicable.
- ↪ Repeat the process until the laser strikes the respective point of the Deflecting Mirror, both on top and on bottom.
- ↪ Turn, tilt or pitch the Deflecting Mirror so that the laser spot strikes either the next Deflecting Mirror or the receiver in both positions.
- ↪ Repeat the process in reverse after setting the laser alignment aid above and below on the receiver. The laser beam must strike the transmitter in both cases if the receiver has been correctly aligned.
- ↪ Remove the laser alignment aid from the safety sensor.

The protective field is free. LED1 on the receiver is permanently lit green. The OSSDs switch on.

### 8.4 Unlocking start/restart interlock

The reset button can be used to unlock the start/restart interlock. In this way, the responsible person can restore the ON state of the safety sensor following process interruptions (due to triggering of protective function, failure of the voltage supply).

 **WARNING**

**Premature unlocking of the start/restart interlock may result in serious injury!**

If the start/restart interlock is unlocked, the system can start-up automatically.

- ↪ Before unlocking the start/restart interlock, make certain that no people are in the danger zone.

The red LED of the receiver illuminates as long as the restart is locked (OSSD off). The yellow LED illuminates when the protective field is free and RES is activated (ready to be unlocked).

- ↪ Make certain that the active protective field is clear.
- ↪ Make certain that there are no people in the danger zone.
- ↪ Press and release the reset button within 0.15 to 4 s.

The receiver switches to the ON state.

If you keep the reset button pressed longer than 4 s:

- Starting at 4 s: the reset request is ignored.
- Starting at 30 s: a +24 V short circuit is assumed on the reset input and the receiver switches to the interlock state (see chapter 11.1 „What to do in case of failure?“).

## 9 Testing

 **WARNING**

**A running machine may result in serious injury!**

↪ Make certain that, during all conversions, maintenance work and inspections, the system is securely shut down and protected against being restarted.

The safety sensors must be exchanged after a maximum of 20 years.

- ↪ Always exchange entire safety sensors.
- ↪ For the tests, observe nationally applicable regulations.
- ↪ Document all tests in a comprehensible manner.

### 9.1 Before the initial start-up and following modifications

 **WARNING**

**Unpredictable machine behavior during initial start-up may result in serious injury!**

↪ Make certain that there are no people in the danger zone.

Acc. to IEC TS 62046 and national regulations (e.g. EU directive 2009/104/EC), tests are to be performed by competent persons in the following situations:

- Prior to the initial start-up
- Following modifications to the machine
- After longer machine downtime
- Following retrofitting or new configuration of the machine
- ↪ Test the effectiveness of the shut-down function in all operating modes of the machine acc. to the following checklist.
- ↪ Document all tests in a comprehensible manner and include the configuration of the safety sensor along with the data for the safety- and minimum distances in the documentation.
- ↪ Before they begin work, train the operators on their respective tasks. The training is the responsibility of the operating company.
- ↪ Attach notices regarding daily testing in the respective national language of the operator on the machine in a highly visible location, e.g. by printing out the corresponding chapter (see chapter 9.3).
- ↪ Check whether the safety sensor was correctly selected acc. to the locally applicable regulations and directives.
- ↪ Check whether the safety sensor is operated acc. to the specified environmental conditions (see chapter 14).
- ↪ Make certain that the safety sensor is protected against overcurrent.
- ↪ Perform a visual inspection for damage and test the electrical function (see chapter 9.2).

Minimum requirements for the power supply unit:

- Safe mains separation
- At least 2 A current reserve
- Power-failure bridging for at least 20 ms

Not until proper function of the Optoelectronic Protective Device is ascertained may it be integrated in the control circuit of the system.



As a safety inspection, Leuze electronic offers testing by a competent person prior to the initial start-up in selected countries (see chapter 13).

#### 9.1.1 Checklist - to be performed prior to the initial start-up and following modifications

**Tester:** competent person



Table 9.1: Checklist - to be performed prior to the initial start-up and following modifications

Check:	Yes	No
Are all standards and guidelines named in this document and machine-specific standards observed?		
Does the Declaration of Conformity of the machine include a listing of these documents?		
Does the safety sensor satisfy the safety-related capability (PL, SIL, category) as required by the risk assessment?		
Are both safety-related switching outputs (OSSDs) integrated in the downstream machine control acc. to the required safety category?		
Are the switching elements (e.g. contactors) with positive-guided contacts that are controlled by the safety sensor monitored by a feedback circuit (EDM)?		
Does the electrical wiring match the circuit diagrams?		
Have the required protective measures against electrical shock been effectively implemented?		
Has the maximum stopping time of the machine been remeasured and recorded in the machine documents?		
Is the required safety distance (protective field of the safety sensor to the next hazard location) maintained?		
Are all hazardous locations of the machine accessible only through the protective field of the safety sensor? Are all additional protective devices (e.g. safety guards) correctly mounted and protected against tampering?		
Is the command device for unlocking the start/restart interlock of the machine mounted in accordance with specifications?		
Is the safety sensor correctly aligned and are all fastening screws and plugs secure?		
Are safety sensor, connecting cable, plug, protection caps and command devices undamaged and without any sign of manipulation?		
Has the effectiveness of the protective function been checked for all operating modes of the machine by means of a function test?		
Is the reset button for resetting the machine mounted outside of the danger zone in accordance with specifications in such a way that it cannot be reached from within the danger zone? Can the entire danger zone be seen from the place at which the reset button is installed?		
Does the interruption of an active light beam with a test object provided for this purpose cause the dangerous movement to stop?		
When the AOPD is separated from its supply voltage, does the dangerous movement stop, and, after the supply voltage has been restored, is it necessary to actuate the reset button to reset the machine?		
Is the safety sensor effective during the entire dangerous movement of the machine?		
Are the notices for daily testing of the safety sensor legible to the operator and are they located in a highly visible location?		



If you answer one of the items on the check list (see table 9.1) with *no*, the machine must no longer be operated.

### 9.2 To be performed periodically by competent persons

The reliable interaction of safety sensor and machine must be periodically tested by competent persons in order to detect changes to the machine or impermissible tampering with the safety sensor. Testing intervals are determined by nationally applicable regulations (recommendation acc. to IEC/TS 62046: 6 months).

- ↪ Have all tests performed by competent persons.
- ↪ Observe the nationally applicable regulations and the time periods specified therein.



As a safety inspection, Leuze electronic offers periodic testing by a competent person in selected countries (see chapter 13).

### 9.3 Daily or at change of shift by the operator

The function of the safety sensor must be checked daily, at change of shifts, and at each change of machine operating mode as specified in the following check list so that damage or unauthorized manipulation can be detected.

**WARNING**

**Unpredictable machine behavior during the test may result in serious injury!**

- ↪ Make certain that there are no people in the danger zone.

#### 9.3.1 Check list – daily or at change of shift

**WARNING**

**Severe injuries can result if the machine is operated when faults occur during daily testing!**

- ↪ Have the entire machine inspected by a competent person (see chapter 9.1).

**Tester:** authorized operator or instructed person

Table 9.2: Check list – daily or at change of shift

Check:	Yes	No
Is the safety sensor aligned correctly? Are all fastening screws tightened and all connectors secured?		
Are safety sensor, connecting cable, plug and command devices undamaged and without any sign of manipulation?		
Are all point of operations at the machine accessible only through one or more protective fields of safety sensors?		
Are all additional protective devices mounted correctly (e.g., safety guard)?		
Does the start/restart interlock prevent the automatic start-up of the machine after the safety sensor has been switched on or triggered?		
<ul style="list-style-type: none"> <li>↪ During operation, interrupt an active light beam with a test object provided for this purpose (see figure 9.1).</li> </ul> Is the dangerous movement shut down immediately?		

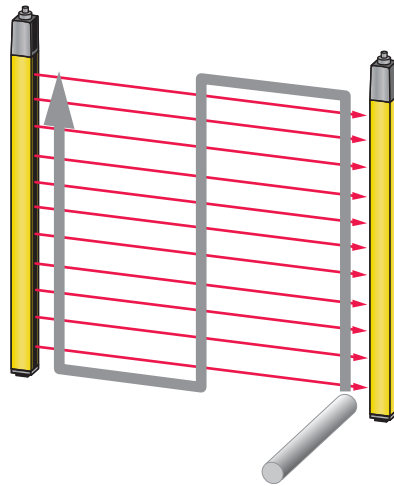

Figure 9.1: Checking the protective field function with test rod (only for safety light curtains with a resolution of 14 to 40 mm)



If you answer one of the items on the check list (see table 9.2) with *no*, the machine must no longer be operated.

- ↪ Stop the dangerous state.
- ↪ Check transmitter, receiver and, if applicable, deflecting mirrors for damage or manipulation.
- ↪ Interrupt all light beams at different distances from the transmitter and receiver with the test rod from a position outside the danger zone (see figure 9.1) and ensure that the machine cannot be started with an interrupted light beam.
- ↪ Start the machine.
- ↪ Ensure that the dangerous state is stopped as soon as an active light beam is interrupted with a test object provided for this purpose.

## 10 Maintenance

**NOTICE****Faulty operation if transmitter and receiver are soiled!**

The surfaces of the front screen of transmitters, receivers and, where applicable, Deflecting Mirror must not be scratched or roughened at the positions where beams enter and exit.

↪ Do not use chemical cleaners.

Prerequisites for cleaning:

- The system is safely shut down and protected against restart.
- ↪ Clean the safety sensor regularly depending on the degree of contamination.

## 11 Rectifying the fault

### 11.1 What to do in case of failure?

After switching the safety sensor on, the display elements (see chapter 3.3) assist in checking the correct functionality and in faultfinding.

In case of failure, you can determine the fault from the LED displays or read a message from the 7-segment display. With the error message you can determine the cause of the fault and initiate measures to rectifying it.

**NOTICE**

**If the safety sensor responds with an error display, you will often be able to eliminate the cause yourself.**

- ↳ Switch off the machine and leave it switched off.
- ↳ Analyze the cause of the error using the following tables (see table 11.1, see table 11.2, see table 11.3) and eliminate the error.
- ↳ If you are unable to rectify the fault, contact the Leuze electronic branch responsible for you or call the Leuze electronic customer service (see chapter 13 „Service and support“).

### 11.2 Operating displays of the LEDs

Table 11.1: Transmitter LED displays - causes and measures

LED	State	Cause	Measure
Transmitter			
LED1	OFF	Transmitter without supply voltage	Check the power supply unit and the electrical connection. Exchange the power supply unit, if applicable.
	red	Transmitter defective	Exchange the transmitter.

Table 11.2: Receiver LED displays - causes and measures

LED	State	Cause	Measure
LED1	OFF	Device failed	Replace the device.
	red (7-segment display during start-up: "C1" or "C2" according to the number of green LEDs on the transmitter)	Alignment incorrect or protective field interrupted	Remove all objects from the protective field. Align the transmitter and receiver to each other or place blanked objects correctly concerning size and position.
	red (7-segment display during start-up: "C1". LEDs on transmitter: both green)	Receiver is set on C1, transmitter on C2	Set the transmitter and receiver on the same transmission channel and align both correctly.
	red (7-segment display during start-up: "C2". (LED1 on transmitter: green)	Receiver is set on C2, transmitter on C1	Remove all objects from the protective field. Align the transmitter and receiver to each other or place blanked objects correctly concerning size and position.
	red, slowly flashing, approx. 1 Hz (7-segment display "E x y")	External fault	Check the connection of the cables and the control signals.
	red, flashing fast, approx. 10 Hz (7-segment display "F x y")	Internal fault	If restart fails, exchange the device.
	green, slowly flashing, approx. 1 Hz	Weak signal due to contamination or poor alignment	Clean the front screens and check the alignment of transmitter and receiver.
LED2	yellow	Start/restart interlock is locked and protective field is free - ready for unlocking	If there are no people in the danger zone, operate the reset button.
	yellow flashing	The control circuit is open in operating mode 1, 2 and 3	Close the input circuit with the correct polarity and timing.

### 11.3 Error messages 7-segment display

Table 11.3: Messages of the 7-segment display (F: internal device error, E: external error, U: usage info during application errors)

Error	Cause/description	Measures	Sensor behavior
F[No. 0-255]	Internal fault	If a restart is unsuccessful, contact customer service.	
OFF	Very high overvoltage ( $\pm 40$ V)	Supply the device with the correct voltage.	
E01	Cross connection between OSSD1 and OSSD2	Check the wiring between OSSD1 and OSSD2.	Automatic reset
E02	Overload on OSSD1	Check the wiring or exchange the connected component (reducing the load).	Automatic reset
E03	Overload on OSSD2	Check the wiring or exchange the connected component (reducing the load).	Automatic reset
E04	High-impedance short circuit to VCC OSSD1	Check the wiring. Exchange the cable, if applicable.	Automatic reset
E05	High-impedance short circuit to VCC OSSD2	Check the wiring. Exchange the cable, if applicable.	Automatic reset
E06	Short circuit against GND at OSSD1	Check the wiring. Exchange the cable, if applicable.	Automatic reset
E07	Short circuit against +24 V at OSSD1	Check the wiring. Exchange the cable, if applicable.	Automatic reset
E08	Short circuit against GND at OSSD2	Check the wiring. Exchange the cable, if applicable.	Automatic reset
E09	Short circuit against +24 V at OSSD2	Check the wiring. Exchange the cable, if applicable.	Automatic reset
E10, E11	OSSD error, source unknown	Check the wiring. Exchange the cable and the receiver if necessary.	Automatic reset
E14	Undervoltage ( $< +15$ V)	Supply the device with the correct voltage.	Automatic reset
E15	Overvoltage ( $> +32$ V)	Supply the device with the correct voltage.	Automatic reset
E16	Overvoltage ( $> +40$ V)	Supply the device with the correct voltage.	Locking
E17	Foreign transmitter detected	Remove foreign transmitters and increase the distance to the reflecting surfaces. Actuate the start button if available.	Locking
E18	Ambient temperature too high	Ensure correct environmental conditions	Automatic reset

Error	Cause/description	Measures	Sensor behavior
E19	Ambient temperature too low	Ensure correct environmental conditions	Automatic reset
E22	Interference detected on plug pin 3. Signal output: output signal is not equal to the signal input read-back value: it switches simultaneously with the other signal line.	Check the wiring.	Automatic reset
E23	Interference detected on plug pin 4. Signal output: output signal is not equal to the signal input read-back value: it switches simultaneously with the other signal line.	Check the wiring.	Automatic reset
E24	Interference detected on plug pin 8. Signal output: output signal is not equal to the signal input read-back value: it switches simultaneously with the other signal line.	Check the wiring.	Automatic reset
E30	EDM does not open	Actuate the start button if available.	Locking
E31	EDM does not close	Actuate the start button if available.	Locking
E37	EDM operating mode changed during operation	Check the correctness of the selected operating mode, correct the operating mode if required, and restart.	Locking
E38	Restart interlock operating mode changed during operation	Check the correctness of the selected operating mode, correct the operating mode if required, and restart.	Locking
E39	Actuation duration (2.5 min) exceeded for reset button or cable short circuited	Press the reset button. If the restart is unsuccessful, check the wiring of the reset button.	Automatic reset
E41	Invalid change of operating mode due to reversal of the supply voltage polarity during operation	Check the wiring and programming of the device which controls this signal.	Locking
E87	Operating mode changed	Check the wiring. Restart the sensor.	Locking



## 12 Disposing

↳ For disposal observe the applicable national regulations regarding electronic components.

## **13 Service and support**

Telephone number for 24-hour standby service:

+49 (0) 702 573-0

Service hotline:

+49 (0) 8141 5350-111

Monday to Thursday, 8.00 a.m. to 5.00 p.m. (UTC+1)

Friday, 8.00 a.m. to 4.00 p.m. (UTC +1)

E-mail:

[service.protect@leuze.de](mailto:service.protect@leuze.de)

Return address for repairs:

Service Center

Leuze electronic GmbH + Co. KG

In der Braike 1

D-73277 Owen/Germany

## 14 Technical data

### 14.1 General specifications

Table 14.1: Protective field data

Physical resolution [mm]	Range [m]		Protective field height [mm]	
	min.	max.	min.	max.
20	0	15	150	3000
30	0	10	150	3000
40	0	20	150	3000
90	0	20	450	3000

Table 14.2: Safety-relevant technical data

Type in accordance with IEC/EN 61496	Type 2
SIL in accordance with IEC 61508	SIL 1
SILCL in accordance with IEC/EN 62061	SILCL 1
Performance Level (PL) in accordance with EN ISO 13849-1	PL c
Category in accordance with EN ISO 13849-1	Cat. 2
Average probability of a failure to danger per hour (PFH <sub>d</sub> )	5.06x10 <sup>-8</sup> 1/h
Service life (T <sub>M</sub> )	20 years

Table 14.3: General system data

Connection technology	M12, 5-pin (transmitter) M12, 8-pin (receiver)
Supply voltage U <sub>v</sub> , transmitter and receiver	+24 V, ± 20 %, compensation necessary at 20 ms voltage dip, min. 250 mA (+ OSSD load)
Residual ripple of supply voltage	± 5 % within the limits of U <sub>v</sub>
Current consumption - transmitter	50 mA
Current consumption receiver	150 mA (without load)
Common value for ext. fuse in the supply line for transmitter and receiver	2 A semi time-lag
Synchronization	Optical between transmitter and receiver
Safety class	III
Protection class	IP65
Temperature range, operation	0 ... 55 °C
Temperature range, storage	-25 ... 70 °C
Relative humidity (non- condensing)	0 ... 95 %

Vibration fatigue limit	5 g, 10 - 55 Hz in accordance with IEC/ EN 60068-2-6; amplitude 0.35 mm
Shock resistance	10 g, 16 ms in accordance with IEC/ EN 60068-2-6
Profile cross-section	29 mm x 35.4 mm
Dimensions	see figure 14.1 and see table 14.7
Weight	see table 14.7

Table 14.4: System data - transmitter

Transmitter diodes, class in accordance with EN 60825-1: 1994 + A1: 2002 + A2: 2001	1
Wavelength	940 nm
Pulse duration	800 ns
Pulse pause	1.9 $\mu$ s (min.)
Mean power	<50 $\mu$ W
Input current pin 4 (range)	Against +24 V: 10 mA Against 0 V: 10 mA

Table 14.5: System data receiver, indication signals and control signals MLC 320

Pin	Signal	Type	Electrical data
1	RES/STATE	Input: Output:	Against +24 V: 15 mA Against 0 V: 80 mA
3	EDM	Input:	Against 0 V: 15 mA
4	RES	Input:	Against 24 V: 15 mA

Table 14.6: Technical data of the electronic safety-related switching outputs (OSSDs) on the receiver

Safety-related PNP transistor outputs (short-circuit monitored, cross-circuit monitored)	Minimum	Typical	Maximum
Switching voltage high active ( $U_v - 1.5V$ )	18 V	22.5 V	27 V
Switching voltage low		0 V	+2.5 V
Switching current		300 mA	380 mA
Residual current		< 2 $\mu$ A	200 $\mu$ A <sup>a)</sup>
Load capacity			0.3 $\mu$ F
Load inductivity			2 H
Permissible wire resistance for load			<200 $\Omega$ <sup>b)</sup>
Permissible wire cross section		0.25 mm <sup>2</sup>	
Permissible cable length between receiver and load			100 m

Safety-related PNP transistor outputs (short-circuit monitored, cross-circuit monitored)	Minimum	Typical	Maximum
Test pulse width		60 μs	340 μs
Test pulse distance	(5 ms)	60 ms	
OSSD restart delay time after beam interruption		100 ms	

- a) In the event of a failure (if the 0 V-cable is interrupted), each of the outputs behaves as a 120 kΩ resistor to U<sub>0</sub>. A downstream safety PLC must not detect this as a logical “1”.
- b) Note the additional restrictions due to cable length and load current.



The safety-related transistor outputs perform the spark extinction. With transistor outputs, it is therefore neither necessary nor permitted to use the spark extinction circuits recommended by contactor or valve manufacturers (RC elements, varistors or recovery diodes), since these considerably extend the decay times of inductive switching elements.

### 14.2 Dimensions, weight, response time

Dimensions, weight and response time are dependent on

- the resolution
- the length

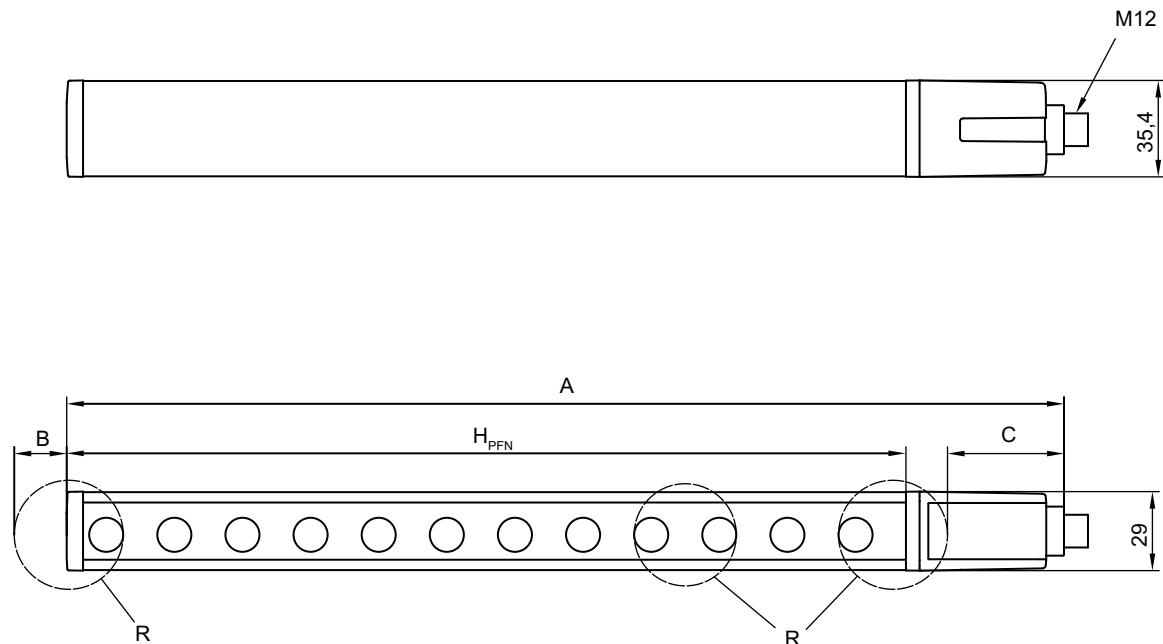

Figure 14.1: Dimensions of transmitter and receiver

Effective protective field height  $H_{PFE}$  goes beyond the dimensions of the optics area to the outer borders of the circles labeled with R.

#### Calculation of the effective protective field height

$$H_{PFE} = H_{PFN} + B - C + 66$$

- $H_{PFE}$  [mm] = Effective protective field height
- $H_{PFN}$  [mm] = Nominal protective field height (see table 14.7); this corresponds to the length of the yellow housing part
- A [mm] = Total height
- B [mm] = Additional dimensions for calculation of the effective protective field height (see table 14.8)
- C [mm] = Value for calculating the effective protective field height (see table 14.8)

Table 14.7: Dimensions (nominal protective field height), weight and response time

Device type	Transmitter and receiver			Receivers			
	Dimensions [mm]		Weight [kg]	Response time [ms] acc. to resolution			
Type	H <sub>PFN</sub> <sup>a)</sup>	A=H <sub>PFN</sub> +66 <sup>b)</sup>		20 mm	30 mm	40 mm	90 mm
MLC...-150	150	216	0.30	4	3	3	-
MLC...-225	225	291	0.37	5	3	3	-
MLC...-300	300	366	0.45	7	4	4	-
MLC...-450	450	516	0.60	9	5	5	3
MLC...-600	600	666	0.75	12	7	7	3
MLC...-750	750	816	0.90	14	8	8	4
MLC...-900	900	966	1.05	17	9	9	4
MLC...-1050	1050	1116	1.20	19	10	10	4
MLC...-1200	1200	1266	1.35	22	12	12	5
MLC...-1350	1350	1416	1.50	24	13	13	5
MLC...-1500	1500	1566	1.65	26	14	14	6
MLC...-1650	1650	1716	1.80	29	15	15	6
MLC...-1800	1800	1866	1.95	31	17	17	7
MLC...-1950	1950	2016	2.10	34	18	18	7
MLC...-2100	2100	2166	2.25	36	19	19	7
MLC...-2400	2400	2466	2.55	41	22	22	8
MLC...-2700	2700	2766	2.85	46	24	24	9
MLC...-3000	3000	3066	3.15	51	26	26	10

a) H<sub>PFN</sub> = nominal protective field height = length of the yellow housing part

b) Total height, see figure 14.1

Table 14.8: Additional dimensions for calculating the effective protective field height

R = resolution	B	C
14 mm	0 mm	52 mm
20 mm	1.5 mm	48 mm
30 mm	13 mm	49 mm
40 mm	19 mm	43 mm
90 mm	44 mm	18 mm

14.3 Dimensional drawings: accessories

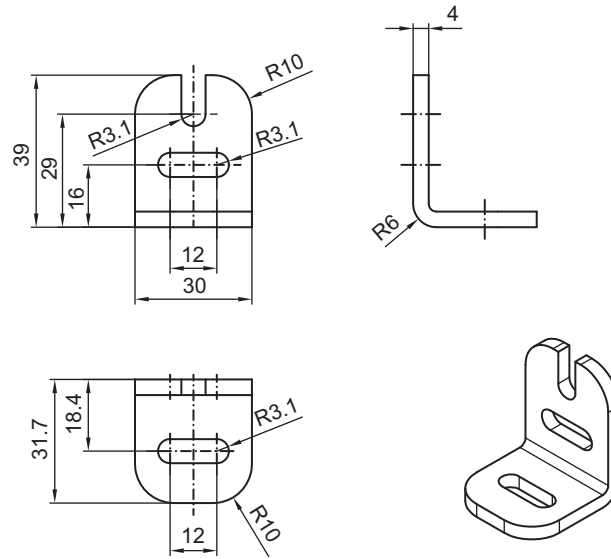

Figure 14.2: BT-L mounting bracket

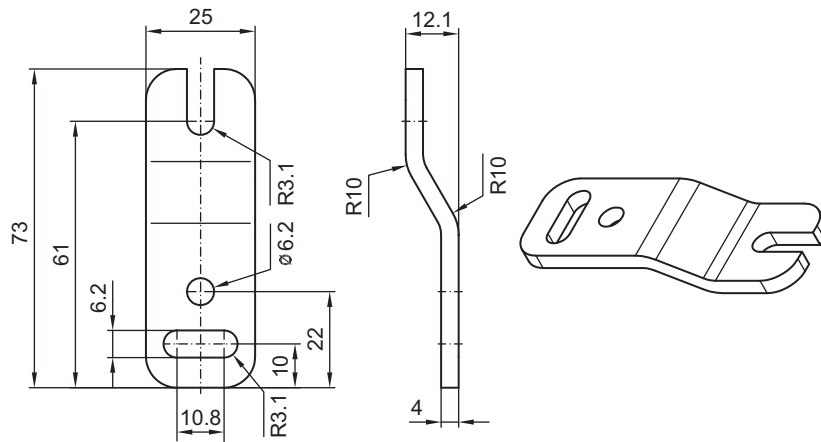

Figure 14.3: BT-Z parallel bracket

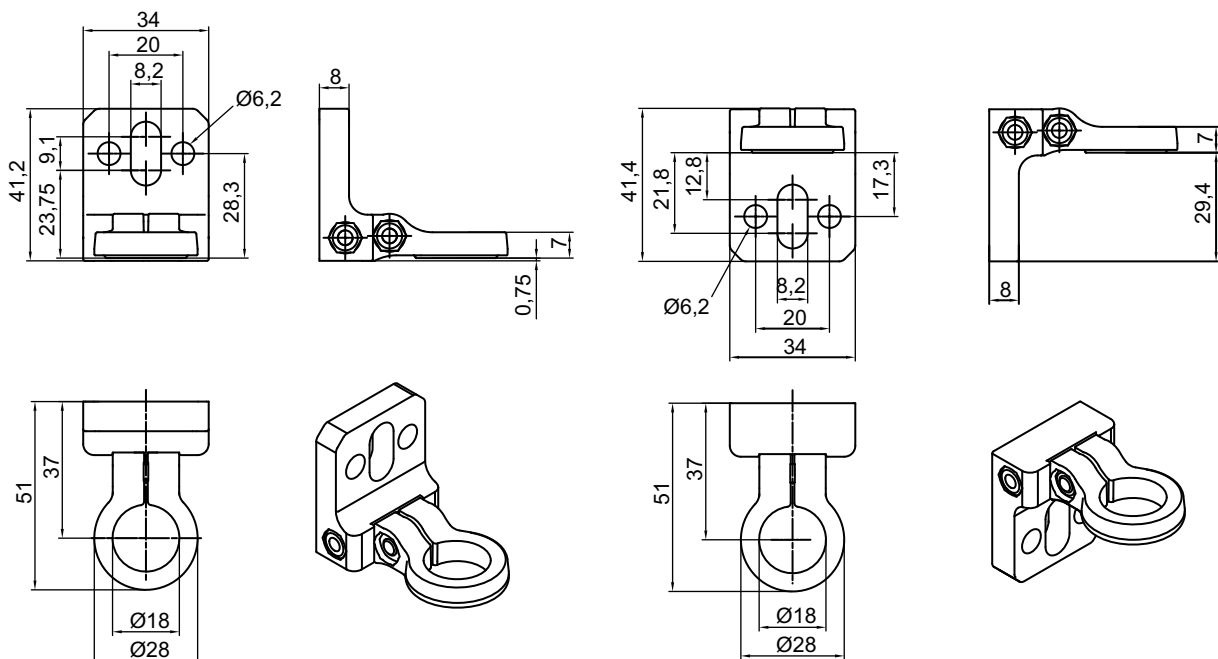

Figure 14.4: BT-R swivel mount

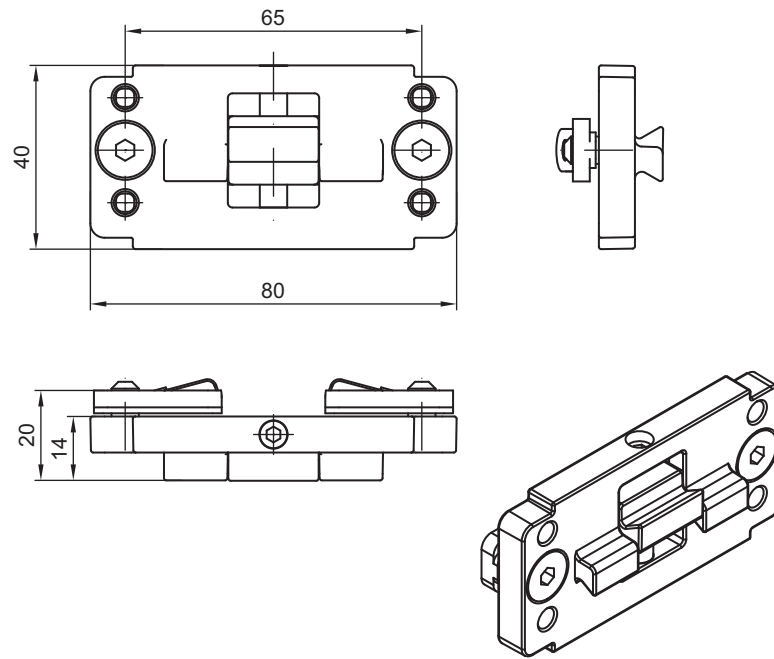

Figure 14.5: BT-P40 clamp bracket

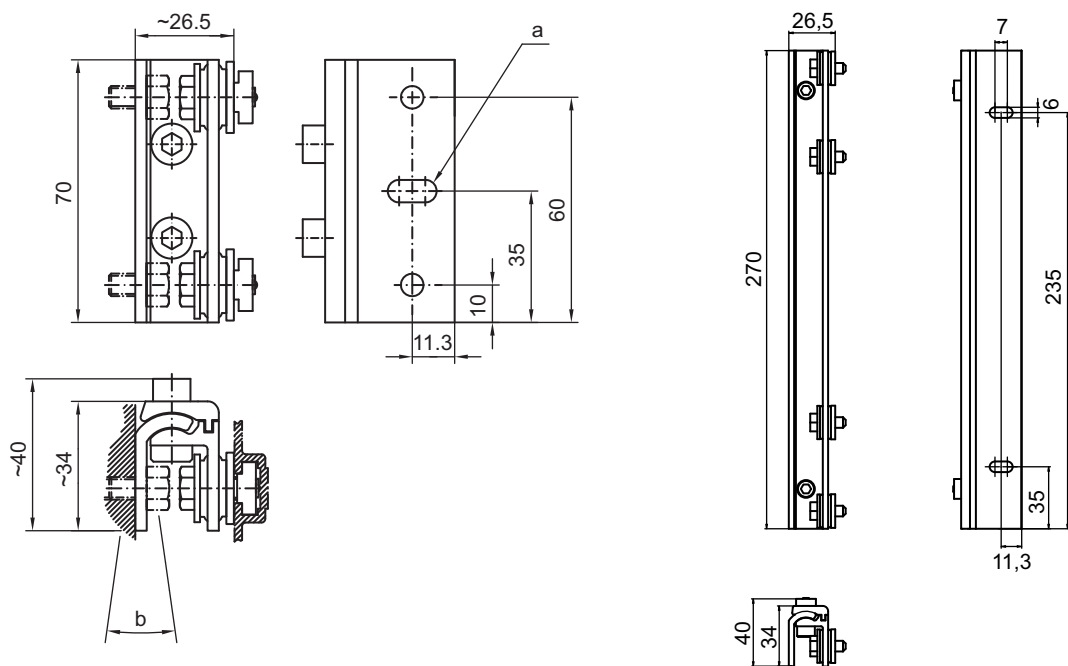

Figure 14.6: BT-SSD and BT-SSD-270 swiveling mounting brackets



## 15 Ordering information and accessories

### Nomenclature

Part description:

**MLCxyy-za-hhhh**

Table 15.1: Article list

MLC	Safety sensor
x	Series: 3 for MLC 300
yy	Function classes: 00: Transmitter 20: Standard receiver - EDM/RES selectable
z	Device type: T: transmitter R: receiver
a	Resolution: 20: 20 mm 30: 30 mm 40: 40 mm 90: 90 mm
hhhh	Protective field height: 150 ... 3000: from 150 mm to 3000 mm

Table 15.2: Part descriptions, examples

Examples for part description	Features
MLC300T20-600	Type 2 transmitter, PL c, SIL 1, resolution 20 mm, protective field height 600 mm
MLC300T30-900	Type 2 transmitter, PL c, SIL 1, resolution 30 mm, protective field height 900 mm
MLC320R90-1500	Type 2 Standard receiver, PL c, SIL 1, resolution 90 mm, protective field height 1500 mm

### Scope of delivery

- Transmitter including 2 sliding blocks, 1 instruction sheet
- Receiver incl. 2 sliding blocks, 1 self-adhesive notice sign "Important notices and notices for the machine operator", 1 connecting and operating instructions (PDF file on CD-ROM)

Table 15.3: Article numbers of MLC 300 transmitter depending on resolution and protective field height

Protective field height hhhh [mm]	20 mm MLC300T20-hhhh	30 mm MLC300T30-hhhh	40 mm MLC300T40-hhhh	90 mm MLC300T90-hhhh
150	68090201	68090301	68090401	-
225	68090202	68090302	68090402	-
300	68090203	68090303	68090403	-
450	68090204	68090304	68090404	68090904
600	68090206	68090306	68090406	68090906

Protective field height hhhh [mm]	20 mm MLC300T20-hhhh	30 mm MLC300T30-hhhh	40 mm MLC300T40-hhhh	90 mm MLC300T90-hhhh
750	68090207	68090307	68090407	68090907
900	68090209	68090309	68090409	68090909
1050	68090210	68090310	68090410	68090910
1200	68090212	68090312	68090412	68090912
1350	68090213	68090313	68090413	68090913
1500	68090215	68090315	68090415	68090915
1650	68090216	68090316	68090416	68090916
1800	68090218	68090318	68090418	68090918
1950	-	-	68090419	68090919
2100	-	-	68090421	68090921
2400	-	-	68090424	68090924
2700	-	-	68090427	68090927
3000	-	-	68090430	68090930

Table 15.4: Article numbers of MLC 320 receiver depending on resolution and protective field height

Protective field height hhhh [mm]	20 mm MLC320R20-hhhh	30 mm MLC320R30-hhhh	40 mm MLC320R40-hhhh	90 mm MLC320R90-hhhh
150	68092201	68092301	68092401	-
225	68092202	68092302	68092402	-
300	68092203	68092303	68092403	-
450	68092204	68092304	68092404	68092904
600	68092206	68092306	68092406	68092906
750	68092207	68092307	68092407	68092907
900	68092209	68092309	68092409	68092909
1050	68092210	68092310	68092410	68092910
1200	68092212	68092312	68092412	68092912
1350	68092213	68092313	68092413	68092913
1500	68092215	68092315	68092415	68092915
1650	68092216	68092316	68092416	68092916
1800	68092218	68092318	68092418	68092918
1950	-	-	68092419	68092919
2100	-	-	68092421	68092921

Protective field height hhhh [mm]	20 mm MLC320R20-hhhh	30 mm MLC320R30-hhhh	40 mm MLC320R40-hhhh	90 mm MLC320R90-hhhh
2400	-	-	68092424	68092924
2700	-	-	68092427	68092927
3000	-	-	68092430	68092930

Table 15.5: Accessories

Part no.	Article	Description
<b>Connection cables for MLC 300 transmitter, shielded</b>		
678055	CB-M12-5000E-5GF	Connection cable, 5-pin, 5 m long
678056	CB-M12-10000E-5GF	Connection cable, 5-pin, 10 m long
678057	CB-M12-15000E-5GF	Connection cable, 5-pin, 15 m long
678058	CB-M12-25000E-5GF	Connection cable, 5-pin, 25 m long
<b>Connection cables for MLC 300 transmitter, unshielded</b>		
429087	CB-M12-5000-5GF	Connection cable, 5-pin, 5 m long
429280	CB-M12-10000-5GF	Connection cable, 5-pin, 10 m long
429088	CB-M12-15000-5GF	Connection cable, 5-pin, 15 m long
429089	CB-M12-25000-5GF	Connection cable, 5-pin, 25 m long
429281	CB-M12-50000-5GF	Connection cable, 5-pin, 50 m long
<b>Connection cables for MLC 320 receiver, shielded</b>		
678060	CB-M12-5000E-8GF	Connection cable, 8-pin, 5 m long
678061	CB-M12-10000E-8GF	Connection cable, 8-pin, 10 m long
678062	CB-M12-15000E-8GF	Connection cable, 8-pin, 15 m long
678063	CB-M12-25000E-8GF	Connection cable, 8-pin, 25 m long
<b>Connection cables for MLC 320 receiver, unshielded</b>		
429285	CB-M12-5000-8GF	Connection cable, 8-pin, 5 m long
429286	CB-M12-10000-8GF	Connection cable, 8-pin, 10 m long
429287	CB-M12-15000-8GF	Connection cable, 8-pin, 15 m long
429288	CB-M12-25000-8GF	Connection cable, 8-pin, 25 m long
429289	CB-M12-25000-8GF	Connection cable, 8-pin, 50 m long
<b>User-configurable connectors for MLC 300 transmitter</b>		
429175	CB-M12-5GF	Cable socket, 5-pin, metal housing, shield on housing
<b>User-configurable connectors for MLC 320 receiver</b>		
429178	CB-M12-8GF	Cable socket, 8-pin, metal housing, shield on housing

Part no.	Article	Description
<b>Mounting technology</b>		
429056	BT-2L	L mounting bracket, 2 pieces
429057	BT-2Z	Z mounting bracket, 2 pieces
429046	BT-2R1	360° swivel mount, 2 pieces incl. 1 MLC cylinder
424417	BT-2P40	Clamp bracket for slot mounting, 2 pieces
429058	BT-2SSD	Swivel mount with shock absorber, $\pm 8^\circ$ , 70 mm long, 2 pieces
429059	BT-4SSD	Swivel mount with shock absorber, $\pm 8^\circ$ , 70 mm long, 4 pieces
429049	BT-2SSD-270	Swivel mount with shock absorber, $\pm 8^\circ$ , 270 mm long, 2 pieces
425740	BT-10NC60	Sliding block with M6 thread, 10 pieces
425741	BT-10NC64	Sliding block with M6 and M4 thread, 10 pieces
425742	BT-10NC65	Sliding block with M6 and M5 thread, 10 pieces
<b>Device Columns</b>		
549855	UDC-900-S2	Device Column, U-shaped, profile height 900 mm
549856	UDC-1000-S2	Device Column, U-shaped, profile height 1000 mm
549852	UDC-1300-S2	Device Column, U-shaped, profile height 1300 mm
549853	UDC-1600-S2	Device Column, U-shaped, profile height 1600 mm
549854	UDC-1900-S2	Device Column, U-shaped, profile height 1900 mm
549857	UDC-2500-S2	Device Column, U-shaped, profile height 2500 mm
<b>Deflecting Mirror Columns</b>		
549780	UMC-1000-S2	Continuous Deflecting Mirror Column 1000 mm
549781	UMC-1300-S2	Continuous Deflecting Mirror Column 1300 mm
549782	UMC-1600-S2	Continuous Deflecting Mirror Column 1600 mm
549783	UMC-1900-S2	Continuous Deflecting Mirror Column 1900 mm
<b>Deflecting Mirror</b>		
529601	UM60-150	Deflecting Mirror, mirror length 210 mm
529603	UM60-300	Deflecting Mirror, mirror length 360 mm
529604	UM60-450	Deflecting Mirror, mirror length 510 mm
529606	UM60-600	Deflecting Mirror, mirror length 660 mm
529607	UM60-750	Deflecting Mirror, mirror length 810 mm
529609	UM60-900	Deflecting Mirror, mirror length 960 mm
529610	UM60-1050	Deflecting Mirror, mirror length 1110 mm
529612	UM60-1200	Deflecting Mirror, mirror length 1260 mm

Part no.	Article	Description
529613	UM60-1350	Deflecting Mirror, mirror length 1410 mm
529615	UM60-1500	Deflecting Mirror, mirror length 1560 mm
529616	UM60-1650	Deflecting Mirror, mirror length 1710 mm
529618	UM60-1800	Deflecting Mirror, mirror length 1860 mm
430105	BT-2UM60	Mounting bracket for UM60, 2 pieces
<b>Protective screens</b>		
347070	MLC-PS150	Protective screen, length 148 mm
347071	MLC-PS225	Protective screen, length 223 mm
347072	MLC-PS300	Protective screen, length 298 mm
347073	MLC-PS450	Protective screen, length 448 mm
347074	MLC-PS600	Protective screen, length 598 mm
347075	MLC-PS750	Protective screen, length 748 mm
347076	MLC-PS900	Protective screen, length 898 mm
347077	MLC-PS1050	Protective screen, length 1048 mm
347078	MLC-PS1200	Protective screen, length 1198 mm
347079	MLC-PS1350	Protective screen, length 1348 mm
347080	MLC-PS1500	Protective screen, length 1498 mm
347081	MLC-PS1650	Protective screen, length 1648 mm
347082	MLC-PS1800	Protective screen, length 1798 mm
429038	MLC-2PSF	Mounting device for MLC protective screen, 2 pieces
429039	MLC-3PSF	Mounting device for MLC protective screen, 3 pieces
<b>Laser alignment aids</b>		
560020	LA-78U	External laser alignment aid
520004	LA-78UDC	External laser alignment aid for fastening in Device Column
<b>Test rods</b>		
349945	AC-TR14/30	Test rod 14/30 mm
349939	AC-TR20/40	Test rod 20/40 mm

**16 EC Declaration of Conformity**



the **sensor** people

EG-KONFORMITÄTS- ERKLÄRUNG (ORIGINAL)	EC DECLARATION OF CONFORMITY (ORIGINAL)	DECLARATION CE DE CONFORMITE (ORIGINAL)
Der Hersteller	The Manufacturer	Le constructeur
	<b>Leuze electronic GmbH + Co. KG</b> In der Braike 1, PO Box 1111 73277 Owen, Germany	
erklärt, dass die nachfolgend aufgeführten Produkte den einschlägigen Anforderungen der genannten EG-Richtlinien und Normen entsprechen.	declares that the following listed products fulfil the relevant provisions of the mentioned EC Directives and standards.	déclare que les produits identifiés suivants sont conformes aux directives CE et normes mentionnées.
Produktbeschreibung:	Description of product:	Description de produit:
<b>Sicherheits- Lichtvorhang, Berührungslos wirkende Schutzeinrichtung, Sicherheitsbauteil nach 2006/42/EG Anhang IV MLC 300, MLC 500</b> Seriennummer siehe Typschild	<b>Safety Light Curtain, Active opto-electronic protective device, safety component in acc. with 2006/42/EC annex IV MLC 300, MLC 500</b> Serial no. see name plates	<b>Barrière immatérielle de sécurité, Équipement de protection électrosensible, Élément de sécurité selon 2006/42/CE annexe IV MLC 300, MLC 500</b> N° série voir plaques signalétiques
Angewandte EG-Richtlinie(n):	Applied EC Directive(s):	Directive(s) CE appliquées:
<b>2006/42/EG</b> <b>2004/108/EG</b>	<b>2006/42/EC</b> <b>2004/108/EC</b>	<b>2006/42/CE</b> <b>2004/108/CE</b>
Angewandte Normen:	Applied standards:	Normes appliquées:
<b>EN 61496-1:2009; IEC 61496-2:2006; EN 55011/A2:2007; EN 50178:1997;</b>	<b>EN ISO 13849-1: 2008 (Kat. 4, Ple)</b>	
Benannte Stelle:	Notified Body:	Organisme notifié:
	<b>TÜV-SÜD PRODUCT SERVICE GmbH</b> <b>Zertifizierungsstelle</b> <b>Ridlerstraße 65</b> <b>D-80339 München</b>	
Bevollmächtigter für die Zusammenstellung der technischen Unterlagen:	Authorized person to compile the technical file:	Personne autorisée à constituer le dossier technique:
	<b>André Thieme; Leuze electronic GmbH + Co. KG</b> <b>Liebigstr. 4; 82256 Fuerstenfeldbruck; Germany</b>	

Owen, 13.08.2013  
Datum / Date / Date



Ulrich Balbach, Geschäftsführer / Director / Directeur

Leuze electronic GmbH + Co. KG  
In der Braike 1  
D-73277 Owen  
Telefon +49 (0) 7021 578  
Telefax +49 (0) 7021 57899  
info@leuze.de  
www.leuze.com

Leuze electronic GmbH + Co. KG, Sitz Owen, Registergericht Stuttgart, HRA 23071  
Persönlich haftende Gesellschafterin Leuze electronic Geschäftsführung GmbH,  
Sitz Owen, Registergericht Stuttgart, HRB 230550  
Geschäftsführer: Ulrich Balbach/Dr. Matthias Kirchherr  
USt-IdNr. DE 145912521 Zollnummer 2554232  
Es gelten ausschließlich unsere aktuellen Verkaufs- und Lieferbedingungen  
Only our current Terms and Conditions of Sale and Delivery shall apply

Nr. 609473-2013/08