

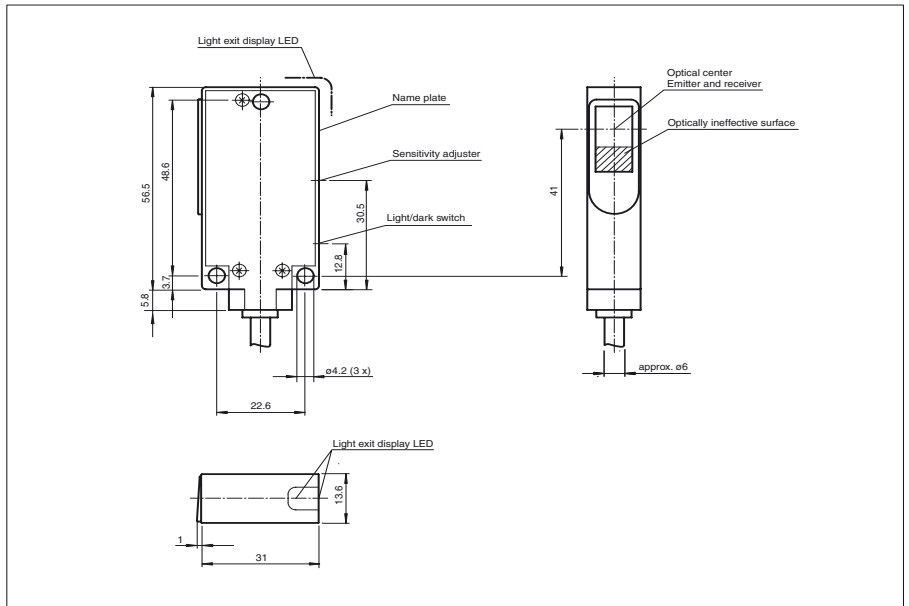

Dimensions



Model Number

MLV40-54-G/40a/49/115

Retro-reflective sensor with polarisation filter for glass detection with 2 m fixed cable

Features

- Sturdy aluminium housing
- Scratch-resistant and solvent resistant optical covering made of glass
- Pre-fault indication
- Detection of transparent materials

Electrical connection

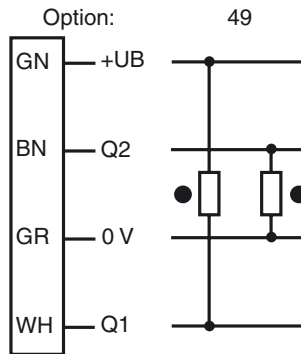

○ = Light on
● = Dark on

Release date: 2006-07-27 08:43 Date of issue: 2007-12-10 418871_ENG.xml

Technical data**General specifications**

Effective detection range	0 ... 400 mm
Reflector distance	0 ... 400 mm
Threshold detection range	1000 mm (with H60 reflector)
Light source	LED
Approvals	CE, cULus
Light type	red, modulated light
Diameter of the light spot	approx. 20 mm at 400 mm detection range
Angle of divergence	approx. 3 °
Ambient light limit	75000 Lux

Indicators/operating means

Function display	LED green, lights up when light beam is free red LED when falling short of the stability control
Operating elements	sensitivity adjuster
Operating elements	Light/dark switch

Electrical specifications

Operating voltage	10 ... 30 V DC
Ripple	5 %
No-load supply current I_0	40 mA

Output

Switching type	light/dark switching
Signal output	1 pnp and 1 npn short-circuit proof, protected against reverse polarity
Switching voltage	max. 30 V DC
Switching current	max. 200 mA
Switching frequency f	500 Hz
Response time	1 ms

Standard conformity

Standards	EN 60947-5-2
-----------	--------------

Ambient conditions

Ambient temperature	-20 ... 60 °C (253 ... 333 K)
Storage temperature	-20 ... 75 °C (253 ... 348 K)

Mechanical specifications

Protection degree	IP65
Connection	fixed cable 2 m
Material	
Housing	aluminium
Optical face	glass
Mass	100 g

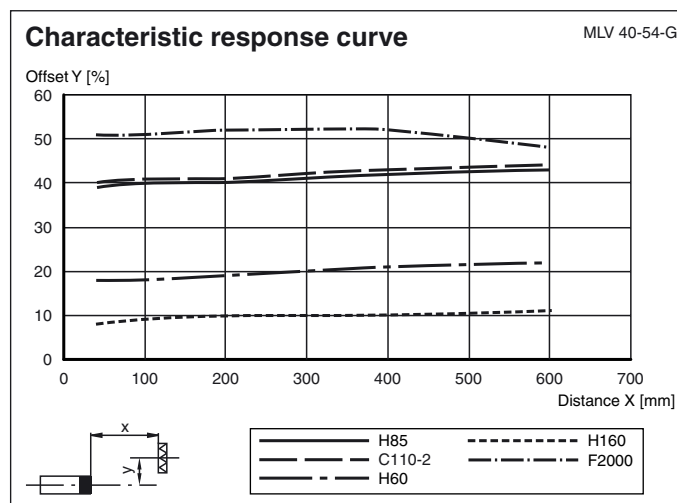
Curves/Diagrams

Relative received light strength

MLV 40-54-G

Reflector type:

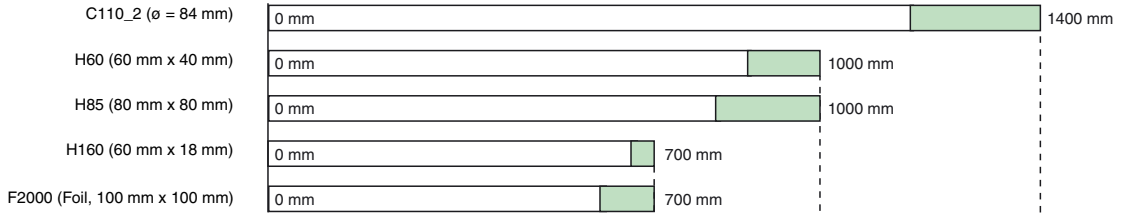

Stability control > 2
 Stability control < 2

Stability control

