

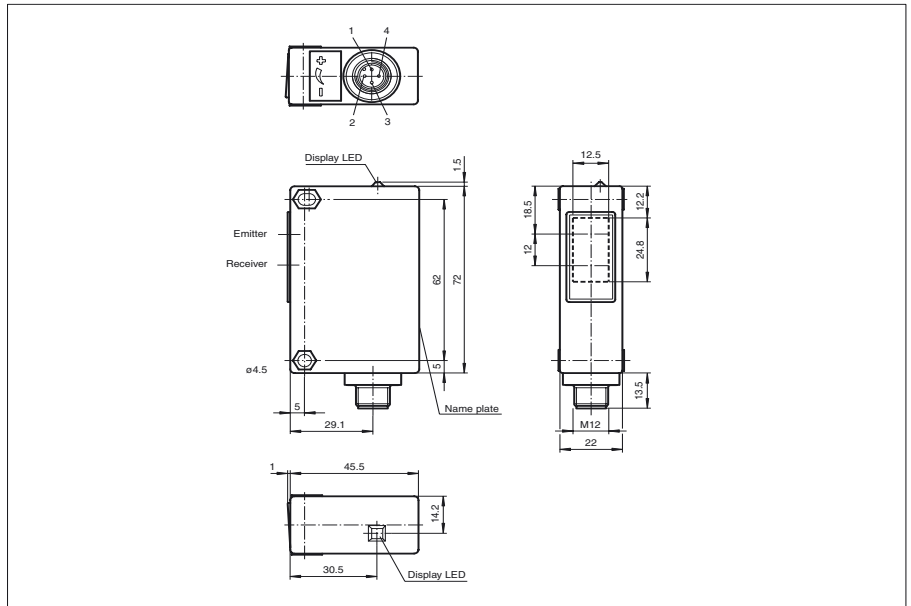

Dimensions



Model Number

RL32-54/32/76a/73c

Retro-reflective sensor with polarisation filter
with 4-pin, M12 x 1 plastic connector

Features

- Glare protected with polarisation filter
- Excellent optical performance data
- Scratch-resistant and solvent resistant optical covering made of glass
- Sleek design, special for storage and conveyor systems

Electrical connection

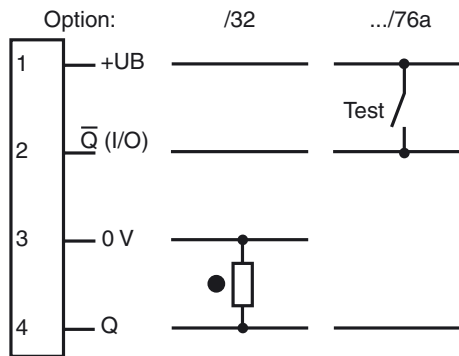

○ = Light on
● = Dark on

Release date: 2008-05-20 08:48 Date of issue: 2008-05-20 419008_ENG.xml

Technical data

General specifications

Effective detection range	0.1 ... 4 m
Reflector distance	0.1 ... 4 m
Threshold detection range	8 m (with H85 reflector)
Light source	LED
Approvals	CE
Light type	red, modulated light
Diameter of the light spot	approx. 200 mm at 4000 mm detection range
Angle of divergence	approx. 3 °
Ambient light limit	80000 Lux

Indicators/operating means

Function display	LED yellow, lights up when light beam is unblocked, flashes when falling short of the stability control
------------------	---

Electrical specifications

Operating voltage	10 ... 30 V DC
Ripple	10 %
No-load supply current I_0	40 mA at 30 V DC

Input

Test input	emitter deactivation with +Ub
------------	-------------------------------

Output

Switching type	dark ON
Signal output	1 PNP output, short-circuit proof, protected from reverse polarity, open collector
Switching voltage	30 V DC
Switching current	max. 200 mA
Switching frequency f	250 Hz
Response time	2 ms

Standard conformity

Standards	EN 60947-5-2
-----------	--------------

Ambient conditions

Ambient temperature	-20 ... 60 °C (253 ... 333 K)
Storage temperature	-20 ... 60 °C (253 ... 333 K)

Mechanical specifications

Protection degree	IP65
Connection	Plastic connector M12 x 1, 4-pin
Material	
Housing	Terluran GV15
Optical face	glass
Mass	60 g

Curves/Diagrams

