



**Model Number**

**RL24-55/49/76a/116**

Retro-reflective sensor with polarization filter  
with terminal compartment

**Features**

- Detection range up to 16 m
- Sturdy plastic housing
- Sensitivity adjuster and light-/dark switch
- Pre-fault indication and output
- 4 programmable time functions
- Operating voltage 10;V ...;30;V;DC or 12;V ...;240;V;AC/DC

**Dimensions**

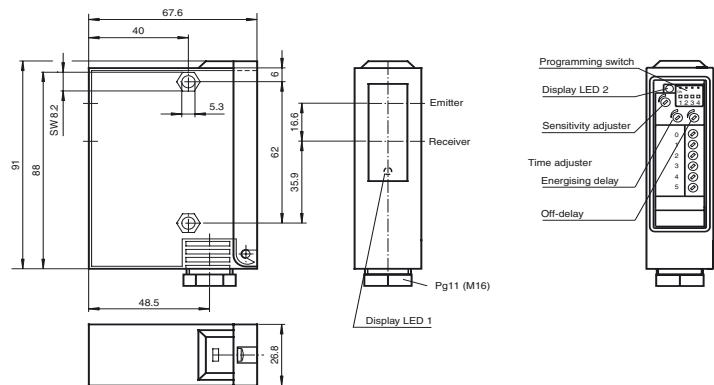

**Electrical connection**

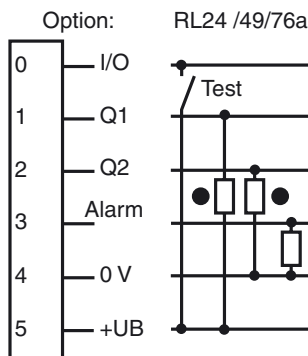

- = Light on
- = Dark on

Release date: 2009-08-18 16:17 Date of issue: 2009-08-18 419026\_ENG.xml

## Technical data

### General specifications

Effective detection range	0.5 ... 10 m
Reflector distance	0.5 ... 10 m
Threshold detection range	16 m (with C110-2 reflector)
Light source	LED
Approvals	CE
USA	UL
Kanada	CSA
Light type	red, modulated light
Diameter of the light spot	approx. 250 mm at 10 m detection range
Angle of divergence	approx. 1.4 °
Ambient light limit	80000 Lux

### Indicators/operating means

Function display	LED yellow, frontal and in the terminal compartment, lit up when light beam is free, flashing when falling short of the stability control
Operating elements	Programming switch for light/dark ON, timer functions
Operating elements	2 potentiometers for timer functions
Operating elements	1 Potentiometer as sensitivity adjuster

### Electrical specifications

Operating voltage	$U_B$	10 ... 30 V DC
Ripple		10 %
No-load supply current	$I_0$	40 mA

### Input

Test input	emitter deactivation at $+U_B$
------------	--------------------------------

### Output

Output of the pre-fault indication	1 pnp	
Switching type	light/dark switching	
Signal output	1 npn, 1 pnp synchronised-switching, short-circuit proof, protected against reverse polarity	
Switching voltage	30 V DC	
Switching current	max. 200 mA	
Switching frequency	$f$	1000 Hz
Response time	0.5 ms	
Timer function	GAN, GAB, IAB, GAN-GAB, programmable adjustment range 0.1 ... 10 s	

### Standard conformity

Standards	EN 60947-5-2
-----------	--------------

### Ambient conditions

Ambient temperature	-20 ... 60 °C (253 ... 333 K)
Storage temperature	-20 ... 75 °C (253 ... 348 K)

### Mechanical specifications

Protection degree	IP65
Connection	terminal compartment
Material	
Housing	GF17
Optical face	glass
Mass	100 g

## Curves/Diagrams

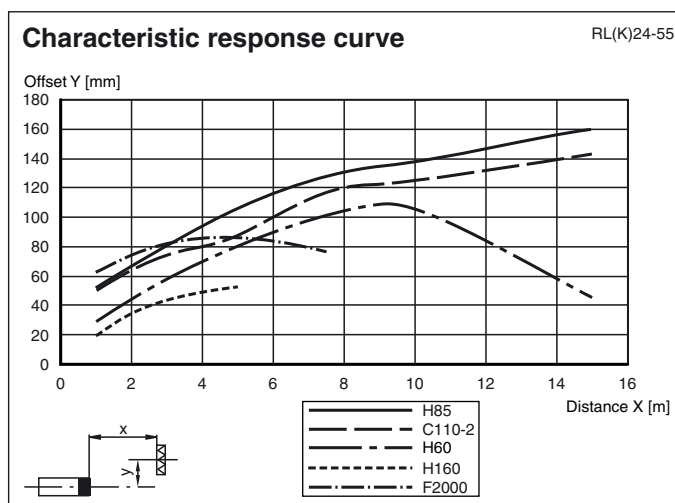

Relative received light strength

Reflector type:

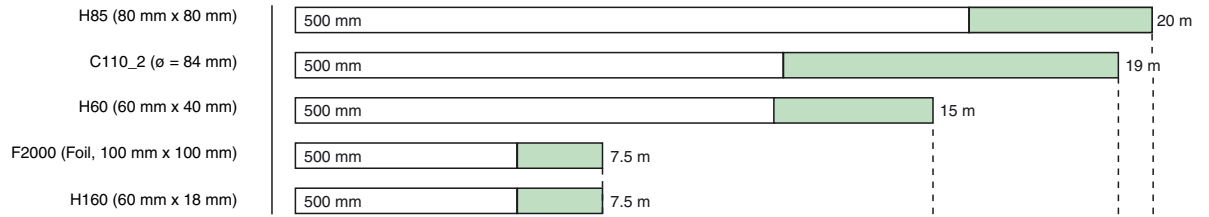

Stability control > 3  
 Stability control < 3

