

MLV11-54-LAS-AS-I/112

Reflection light beam switch with AS-i

MLV11-54-LAS-AS-I/112

with 4-pin M12 connector, 90° adjustable position



- ◆ Detection range up to 15 m
- ◆ Glare protected with polarisation filter
- ◆ Visible red light
- ◆ Pre-fault indication and output (dynamic and static)
- ◆ Automatic adjustment of sensitivity per TEACH-IN
- ◆ Detection of partially transparent objects
- ◆ Parameterisation via optical communication link (e.g. optional time increments)
- ◆ Protection degree IP68
- ◆ All materials approved for food industry applications
- ◆ Multifunction input

Release date: 2004-07-28 16:21 Date of issue: 2005-07-04 421564_ENG.xml

General specifications

Effective detection range	0 ... 15 m
Reflector distance	300 ... 15000 mm
Light source	laser diode
Approvals	CE
Laser class	2
Reference target	H60 reflector
Light type	Red light 670 nm pulsed LASER-light (12 µs), 2 mW peak power, laser class 2, eye-safe
Diameter of the light spot	50 mm at a distance of 15 m
Ambient light limit	10000 Lux

Indicators/operating means

Operating display	LED green
Function display	TEACH-IN: LED green flashing switching state: LED yellow pre-fault indicator: LED red flashing
Operating elements	membrane keys for setting sensitivity and TEACH IN

Electrical specifications

Operating voltage	via AS-Interface network
Time delay before availability t_v	≤ 80 ms

Output

Switching type	light/dark switching
Signal output	AS-Interface
Switching current	≤ 35 mA
Switching frequency f	≤ 1000 Hz
Response time	≤ 0.5 ms
Timer function	parameterisable

Standard conformity

Standards	EN 60947-5-2
-----------	--------------

Ambient conditions

Ambient temperature	-25 ... 70 °C (248 ... 343 K)
Storage temperature	-40 ... 70 °C (233 ... 343 K)

Mechanical specifications

Protection degree	IP68
Connection	4-pin M12 x 1 connector, 90° adjustable position
Material	
Housing	PBT
Optical face	scratch resistant plastic lens
Mass	60 g

Release date: 2004-07-28 16:21 Date of issue: 2005-07-04 421564_ENG.xml



MLV11-54-LAS-AS-I/112

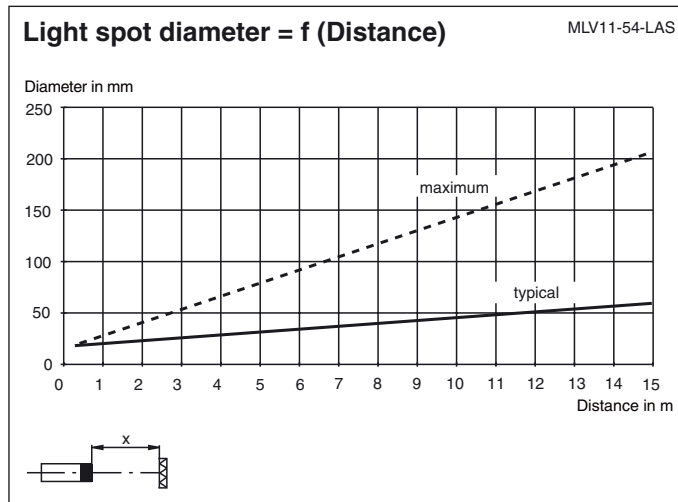

AS-Interface programming

Address preset to 00, can be changed via Busmaster or programming devices

IO code 1

ID code F

• Data bit

Bit	Function
D0	switch output
D1	pre-fault indication (0=ON, 1=OFF)
D2	antivalent switch output
D3	function input

• Parameter bit

Bit	Function
P0	not used
P1	not used
P2	not used
P3	not used

Dimensions

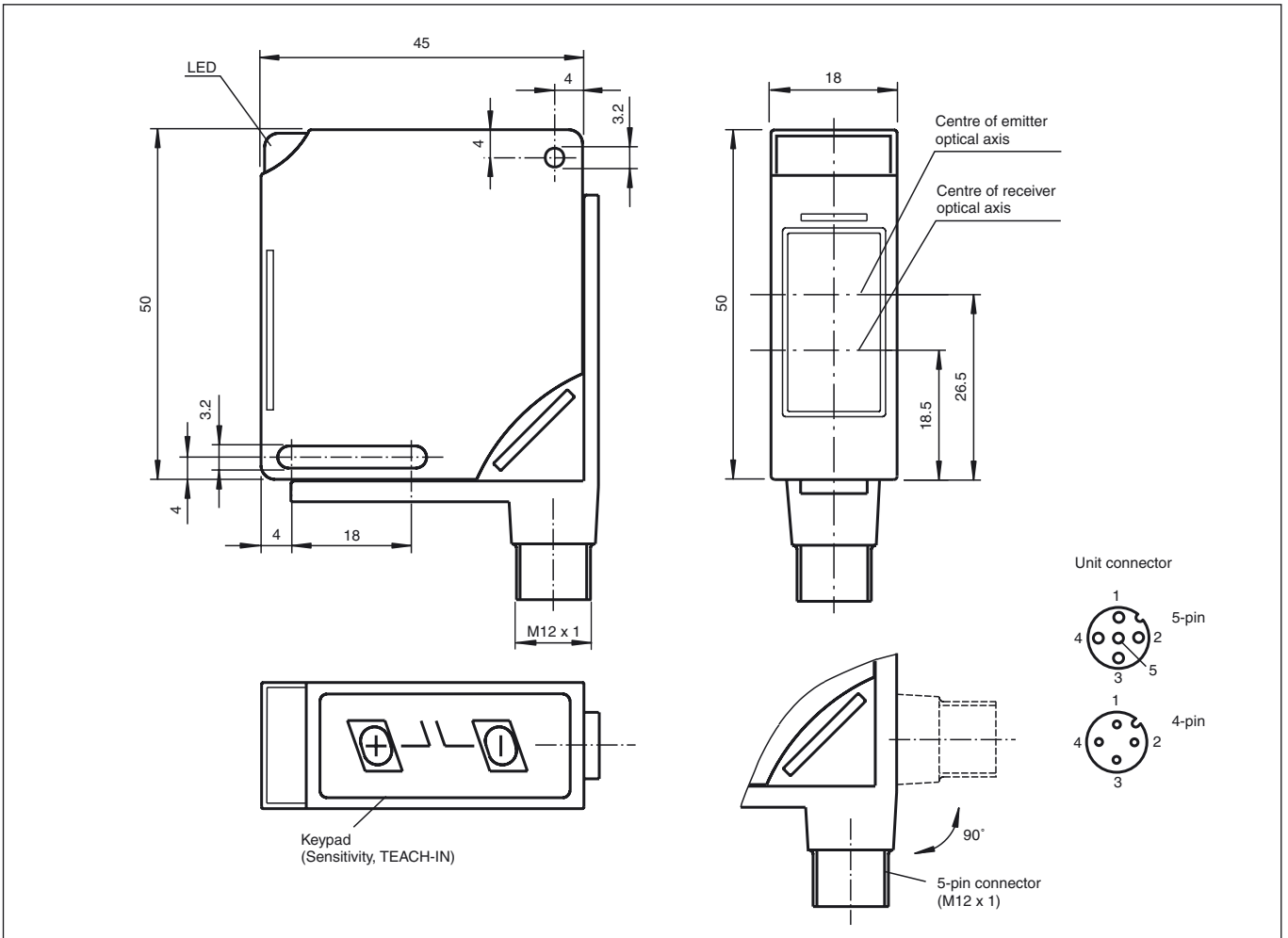

Electrical connection

Option:

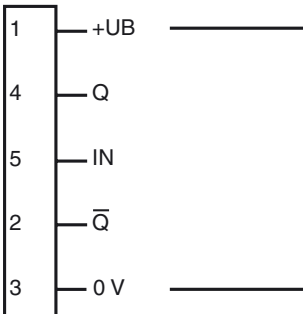

○ = light on, ● = dark on