

MLV11-54-E/47/112

Retroreflective sensor

MLV11-54-E/47/112

with 5-pin M12 connector, 90° adjustable position

CE



- ◆ Detection range up to 9 m
- ◆ Glare protected with polarisation filter
- ◆ Visible red light
- ◆ Pre-fault indication and output (dynamic and static)
- ◆ Automatic adjustment of sensitivity per TEACH-IN
- ◆ Detection of partially transparent objects
- ◆ Parameterisation via optical communication link (e.g. optional time increments)
- ◆ Protection degree IP68
- ◆ All materials approved for food industry applications
- ◆ Multifunction input

Release date: 2006-08-15 15:42 Date of issue: 2006-08-15 421590_ENG.xml

General specifications

Effective detection range	0 ... 6 m
Reflector distance	600 ... 6000 mm
Threshold detection range	9 m
Light source	LED
Approvals	CE
Reference target	H85 reflector
Light type	red, modulated light
Diameter of the light spot	200 mm at a distance of 6000 mm
Ambient light limit	10000 Lux

Indicators/operating means

Operating display	LED green
Function display	TEACH-IN: LED green flashing switching state: LED yellow pre-fault indicator: LED red flashing
Operating elements	membrane keys for setting sensitivity and TEACH IN

Electrical specifications

Operating voltage	10 ... 30 V DC
Ripple	10 %
No-load supply current I_0	≤ 25 mA
Time delay before availability t_v	≤ 80 ms

Input

Test input	inactive: ≤ 3 V or unwired; active: ≥ 7 V
------------	---

Output

Output of the pre-fault indication	pnp, dynamic/static configurable
Switching type	light/dark switching
Signal output	2 switch outputs pnp, parameterisable as - NO/NC (antivalent) - NO and pre-fault indication - NC and pre-fault indication
Switching voltage	max. 30 V DC
Switching current	max. 200 mA
Voltage drop U_d	≤ 2.5 V
Switching frequency f	≤ 1000 Hz
Response time	≤ 0.5 ms
Timer function	parameterisable

Standard conformity

Standards	EN 60947-5-2
-----------	--------------

Ambient conditions

Ambient temperature	-25 ... 70 °C (248 ... 343 K)
Storage temperature	-40 ... 70 °C (233 ... 343 K)

Mechanical specifications

Protection degree	IP68
Connection	5-pin M12 x 1 connector, 90° adjustable position
Material	
Housing	PBT
Optical face	scratch resistant plastic pane
Mass	60 g

Release date: 2006-08-15 15:42 Date of issue: 2006-08-15 421590_ENG.xml

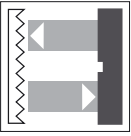

MLV11-54-E/47/112

Curves/Diagrams

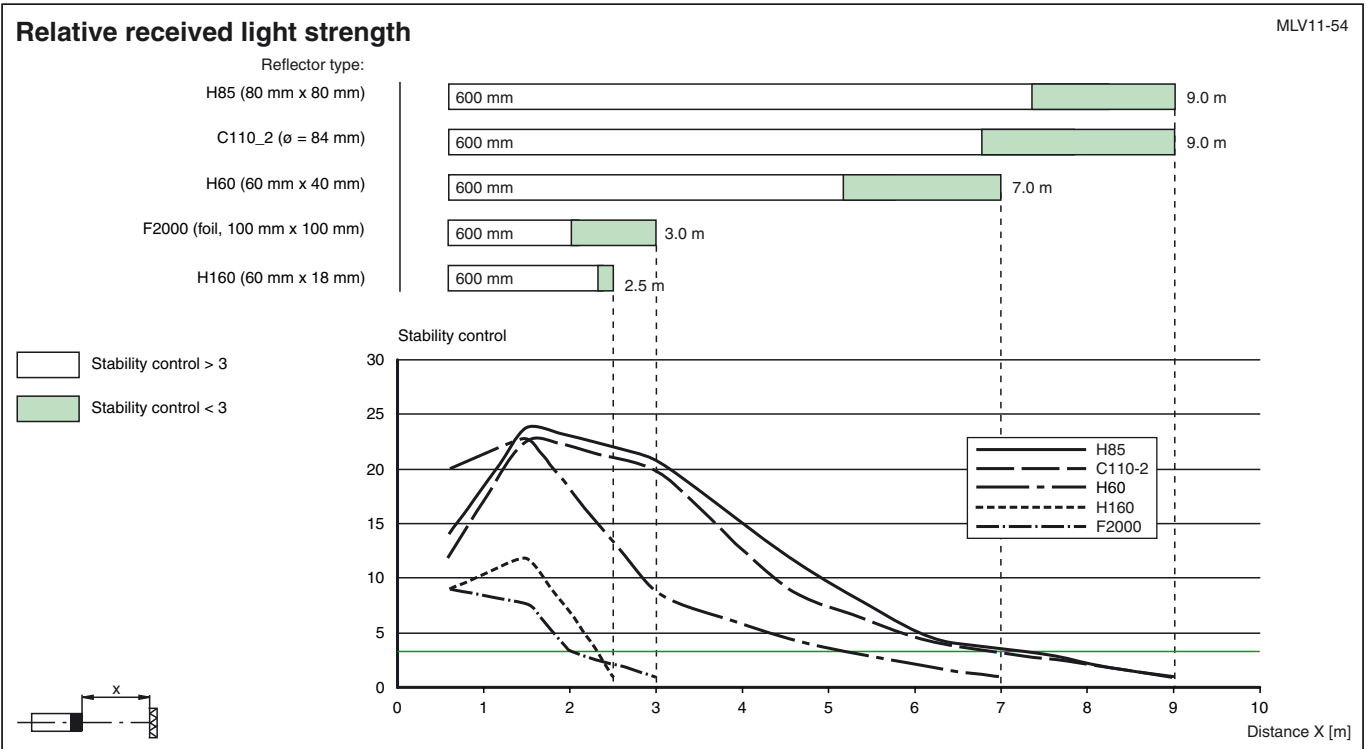
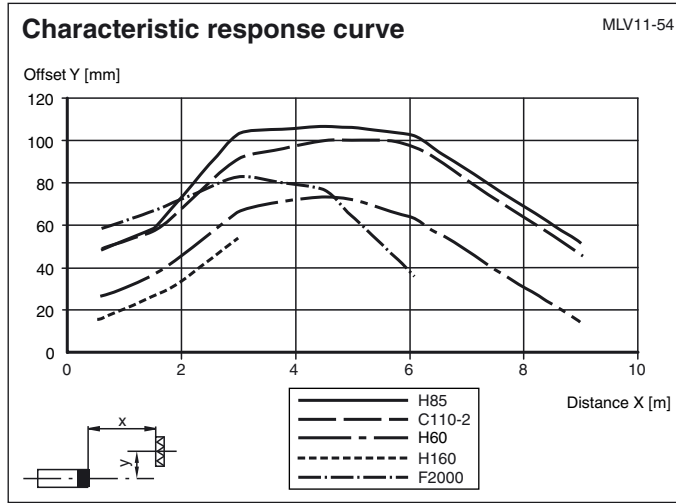

Release date: 2006-08-15 15:42 Date of issue: 2006-08-15 421590_ENG.xml

Dimensions

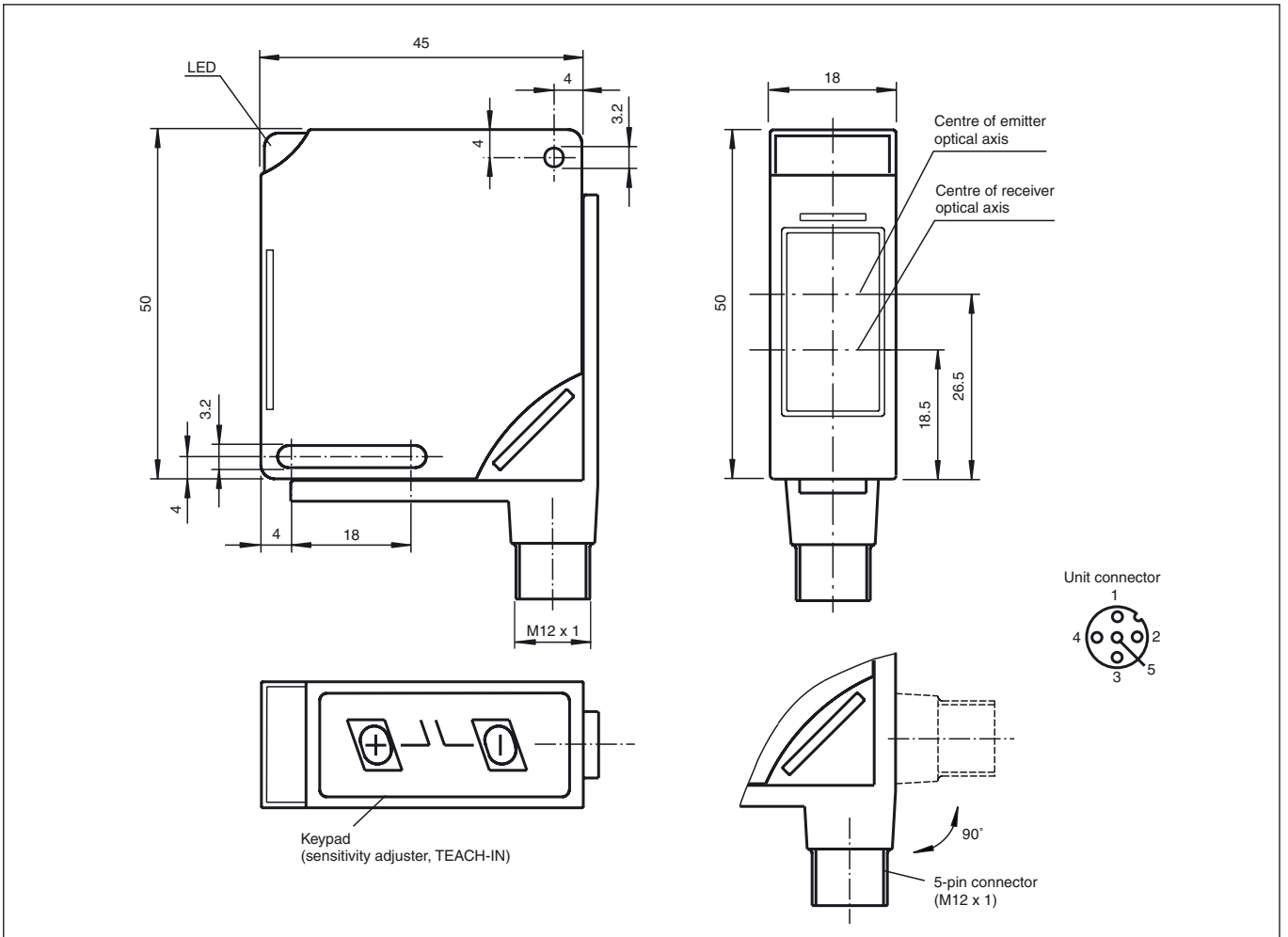

Electrical connection

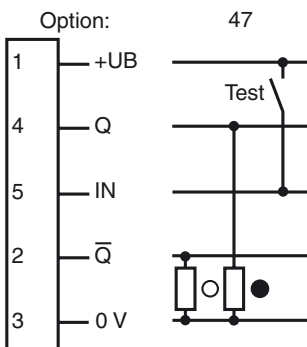

○ = light on, ● = dark on